

Assignment 3c

December 2, 2003

Half Scale Joint – Part II

This assignment is due December 15 9AM

INTRODUCTION

Part two is a continuation of the previous assignment. Here your job is to mill joints too complex to cut on the water-jet cutter. The goal here is not to create highly polished pieces but to demonstrate design intention by creating assemblies from milled aluminum. Make sure to not start with blocks larger than 6" x 6" x 8". You may want to pre or post drill holes for screws and parts.

SCALE = 1' = 6"

FABRICATION PROCESS

See Online Manual for FeatureCAM and Denford Milling

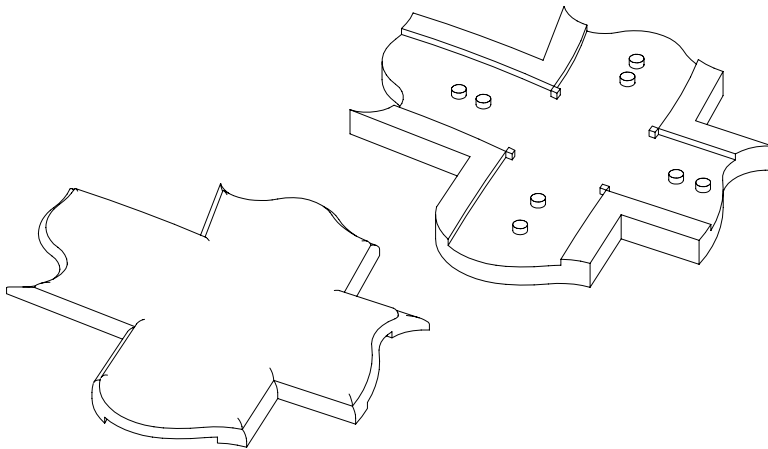

Fig. 1 Files for parts to be milled

**TOTAL ASSIGNMENT
TURN IN PROCEDURE – DUE MONDAY DECEMBER 15, 2003**

- 1) Once fabricated: Drop off all Models on the metal shelves next to the Stratasys Printer
- 2) SUBMIT AS ONE PDF FILE
NO MORE THAN 7 PAGES INCLUDING THE TITLE PAGE
 - a) TITLE PAGE
 - Name, Date, Assignment #
 - Photo if you like
 - b) MILLED MODEL (Assignment 3A)
 - Photo of 2 Models
 - Screen Capture of Design Model from Rhino or AutoCAD (Axonometric View)
 - c) ASSEMBLY OF METAL MODELS (Assignment 3B & 3C)
 - Photo of Final Model
 - Line Drawing of Design Model (Axonometric View)
 - Line Drawing of Construction Model (Axonometric View)
 - Line Drawing of Cut-sheets