

# Spacecraft Power for Cassini



Cassini's electrical power source — Radioisotope Thermoelectric Generators (RTGs) — have provided electrical power for some of the U.S. space program's greatest successes, including the Apollo lunar landings and the Viking landers that searched for life on Mars. RTGs made possible NASA's celebrated Voyager explorations of Jupiter, Saturn, Uranus and Neptune, as well as the Pioneer missions to Jupiter and Saturn. RTG power sources are enabling the Galileo mission to Jupiter, the international Ulysses mission studying the Sun's polar regions, and the Cassini mission to Saturn.

Extensive studies conducted by NASA's Jet Propulsion Laboratory (JPL) showed that NASA's Cassini mission, given its science objectives, available launch systems, travel time to its destination and Saturn's extreme distance from the Sun, requires RTGs.

## What Are RTGs?

RTGs are lightweight, compact spacecraft power systems that are extraordinarily reliable. RTGs are not nuclear reactors and have no moving parts. They use neither fission nor fusion processes to produce energy. Instead, they provide power through the natural radioactive decay of plutonium (mostly Pu-238, a non-weapons-grade isotope). The heat generated by this natural process is changed into electricity by solid-state thermoelectric converters.

## Safety Design

The United States has an outstanding record of safety in using RTGs on 24 missions over the past three decades. While RTGs have never caused a spacecraft failure on any of

these missions, they have been on-board three missions which experienced malfunctions for other reasons. In all cases, the RTGs performed as designed.

More than 30 years have been invested in the engineering, safety analysis and testing of RTGs. Safety features are incorporated into the RTGs' design, and extensive testing has demonstrated that they can withstand physical conditions more severe than those expected from most accidents.

First, the plutonium dioxide fuel is used in its heat-resistant, ceramic form which reduces its chance of vaporizing in fire or reentry environments. This ceramic-form fuel is also highly insoluble, has a low chemical reactivity, and if fractured, tends to break into large, non-respirable particles and chunks. These characteristics help to mitigate the potential health effects from accidents involving the release of this fuel.

Second, the fuel is divided among 18 small, independent modular units, each with its own heat shield and impact shell. This design reduces the chances of fuel release in an accident because all modules would not be equally impacted in an accident.

Third, multiple layers of protective materials, including iridium capsules and high-strength graphite blocks, are used to protect the fuel and prevent its accidental release. Iridium is a metal that has a very high melting point and is strong, corrosion-resistant and chemically compatible with plutonium dioxide. These characteristics make iridium useful for protecting and containing each fuel pellet. Graphite is used because it is lightweight and highly heat-resistant.

The multiple protective layers of an RTG heat source.

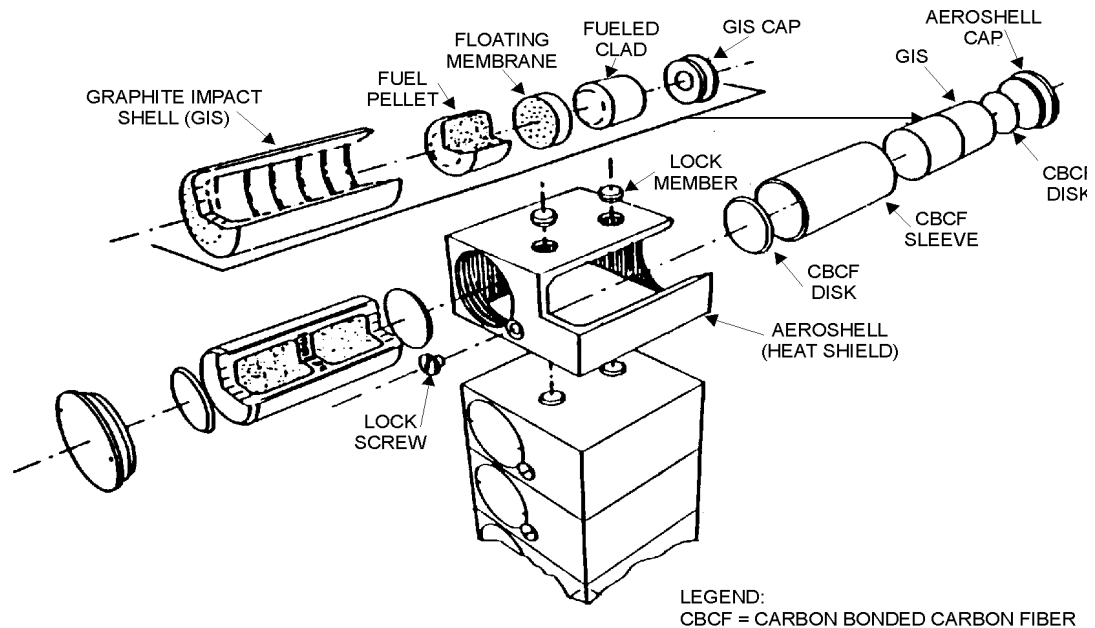

Potential RTG accidents are sometimes mistakenly equated with accidents at nuclear power plants. It is completely inaccurate to associate an RTG accident with Chernobyl or any other past radiation accident involving fission. RTGs do not use either a fusion or fission process and could never explode like a nuclear bomb under any accident scenario. Neither could an accident involving an RTG create the acute radiation sickness similar to that associated with nuclear explosions.

Thorough and detailed safety analyses are conducted prior to launching NASA spacecraft with RTGs, and many prudent steps are taken to reduce the risks involved in NASA missions using RTGs. In addition to NASA's internal safety requirements and reviews, missions that carry nuclear material also undergo an extensive safety review involving detailed verification testing and analysis. Further, an independent safety evaluation of these missions is performed as part of the nuclear launch safety approval process by an ad-hoc Interagency Nuclear Safety Review Panel (INSRP), which is supported by experts from government, industry and academia.

### Non-Nuclear Alternatives to RTGs

NASA found that even with solar arrays containing the latest high-efficiency solar cells developed by the European Space Agency (ESA) it would not have been possible to conduct the Cassini mission using solar power. This is because the arrays, in order to meet Cassini's electrical power requirements, would have had to be so large that the spacecraft as a whole would have been too massive to launch.

### Cassini's Earth Swingby

By aiming a spacecraft so that it passes very close to a planet or moon, it is possible to boost the spacecraft on to more distant destinations with greater velocity. Called the "slingshot effect" or, more properly, a gravity-assist swingby, this maneuver has become an established method of launching massive, instrument-laden spacecraft to the outer planets. Cassini has made use of this technique by swinging by Venus once already, and will swing by Venus once more and then the Earth and Jupiter to reach its ultimate destination of Saturn.

The Earth swingby was designed to ensure that the probability of a reentry into Earth's atmosphere during the maneuver is extremely low, less than one in one million. NASA's robotic planetary spacecraft have performed numerous similar maneuvers with extraordinary precision. The redundant design of Cassini's systems and navigational capability allows control of the swingby altitude at Earth to within an accuracy of 3 to 5 kilometers (2 to 3 miles) at an altitude of about 1166 kilometers (725 miles). NASA's Galileo spacecraft achieved similar accuracies when it flew by Earth in 1990 and 1992.

In addition, NASA has taken specific actions to design the spacecraft and mission in such a way as to ensure the probability of Earth impact is less than one in one million. For example, until 7 days before the Earth swingby, the spacecraft is on a trajectory that, without any further maneuvers, would miss the Earth by thousands of kilometers. The biased trajectory also strictly limits the possibility that random external events (such as a micrometeoroid puncture of a spacecraft propellant tank) might lead to Earth impact.

### Radiation Hazards of Plutonium-238

It is important to understand that exposure of a person to radiation does not mean that person will get cancer. People are exposed to radiation on a daily basis, mainly from natural sources in the environment and to a lesser extent from human activities such as medical X-rays. This radiation exposure is measured in units of dose called millirem. Natural sources of radiation include radon, other naturally occurring radioactive material in the Earth, cosmic rays, and even some radioactive materials that naturally occur in a person's body (see Figure 1). All of these radiation sources contribute to what is often referred to as "background radiation." Over the course of a year, the average person will be exposed to a total of about 360 millirem of background radiation, with about 300 millirem

of that total coming from natural background radiation (that is radon, cosmic rays, and rocks and soils). Over 50 years, the average person will be exposed to about 15,000 millirem of natural background radiation.

Scientists use what is called a health effects estimator to predict how many people in a population who are exposed to radiation would be expected to die from cancer. The number of fatalities increases with the amount of radiation; the more radiation to the same size population the more health effects would be predicted. As an example, people living in Denver, at an altitude of 1,500 meters (5,000 feet), receive an annual radiation dose that is higher than those who live near sea level. The extra radiation dose from cosmic radiation contributes about an extra annual 30 millirem to each person in Denver. Using the health effects estimator, a scientist would calculate a slightly higher estimate of health effects in Denver than in the same sized city near sea level because of this extra 30 millirem.

This scaling method of estimating cancer fatalities from radiation dose may overestimate the number of expected fatalities from low level radiation. This is because some scientists have evidence suggesting there may be a minimal threshold of radiation exposure necessary for a cancer fatality to be possible. These scientists reason that the human body may repair the small number of cells that may be damaged from low level radiation exposure. NASA, however did not take this approach for Cassini, but used the more conservative approach that assumes that even the lowest dose can have an affect.

In the extremely unlikely event that a Cassini inadvertent Earth reentry has occurred, some plutonium dioxide could be released into the atmosphere. The fine particles of plutonium dioxide that are potentially hazardous to people would remain high in the atmosphere for a long period of time. This would result in the

particles being spread very thinly across the world and eventually making their way to the surface, mostly the oceans. Since the material is highly insoluble, once it reaches the surface most of it would become trapped in the oceans or soils and not pose a health hazard. Thus, most of the released material would not be breathed in by people. The small amount of released material that would be breathed in would be distributed over much of the world. Since the amount to be breathed in is so tiny, the radiation dose that a person would be expected to receive is less than one millirem total over 50 years. This small radiation dose is indistinguishable when compared to the 15,000 millirem dose an average person will receive (over that same 50 year period) from natural background radiation.

## **CONCLUSION**

RTGs enable spacecraft to operate at significant distances from the Sun or in other areas where solar power systems would not be feasible. They remain unmatched for power output, reliability and durability by any other power source for missions to the outer solar system and are very safe.

For more information, please contact:

Cassini Public Information  
Jet Propulsion Laboratory  
4800 Oak Grove Drive  
Pasadena, CA 91109  
818-354-5011  
<http://www.jpl.nasa.gov/cassini/>