

**6.003: Signals and Systems—Fall 2003**

PROBLEM SET 8 SOLUTION

**Exercise for home study**

**O&W 8.35**

(a) From the system diagram, we see that

$$z(t) = x(t) \cos(\omega_c t)$$

Using the multiplication property

$$Z(j\omega) = \frac{1}{2\pi} (X(j\omega) * \mathcal{FT}\{\cos \omega_c t\})$$

FT of  $\cos \omega_c t$  is two impulses with area  $\pi$  at  $\pm \omega_c$ . Therefore,  $Z(j\omega)$  is the spectrum of  $X(j\omega)$  shifted to be centered at  $\omega_c$  and  $-\omega_c$  and scaled by  $\frac{1}{2\pi} \times \pi = \frac{1}{2}$ . The real and imaginary parts of  $Z(j\omega)$  are shown below:

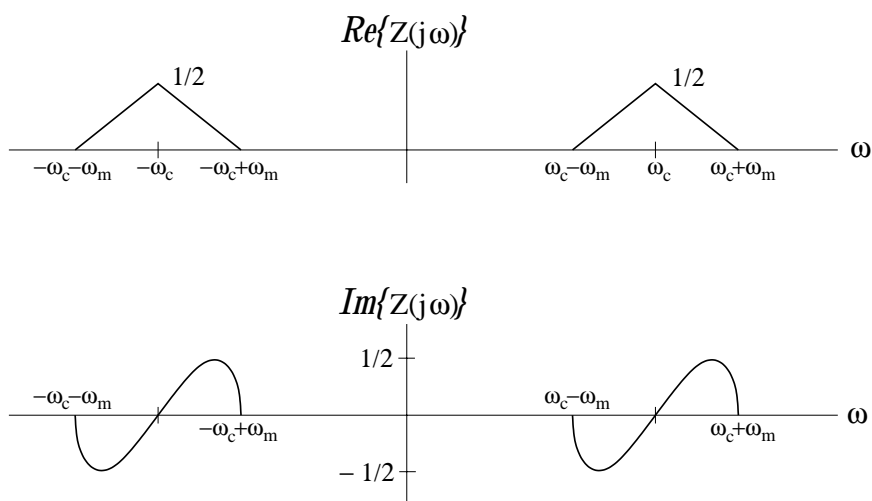

To find FT of  $p(t)$ , let us first define a signal,  $q(t)$ , such that:

$$q(t) = \begin{cases} 2, & |w| \leq \frac{\pi}{2\omega_c} \\ 0, & |w| > \frac{\pi}{2\omega_c} \end{cases}$$

Therefore,

$$p(t) = \left[ q(t) * \sum_{n=-\infty}^{+\infty} \delta\left(t - n\frac{2\pi}{\omega_c}\right) \right] - 1$$

Taking Fourier transform,

$$P(j\omega) = \frac{4 \sin\left(\frac{\pi\omega}{2\omega_c}\right)}{\omega} \left[ \omega_c \sum_{k=-\infty}^{\infty} \delta(\omega - k\omega_c) \right] - 2\pi\delta(\omega)$$

Following is the plot of  $P(j\omega)$ .  $\Im\{P(j\omega)\} = 0$ .

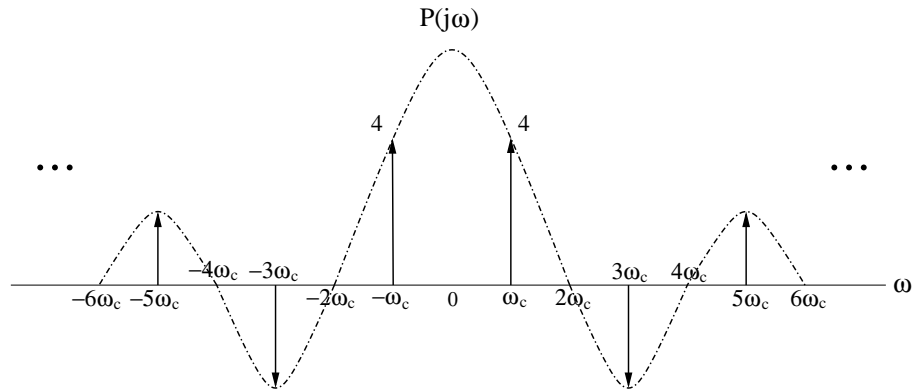

Note that the impulse at the origin disappeared in the above graph because of the subtraction with  $2\pi\delta(\omega)$ .

Now, using the multiplication property again,  $Y(j\omega) = \frac{1}{2\pi}(Z(j\omega) * P(j\omega))$ .

The real and imaginary part of  $Y(j\omega)$  is shown below:

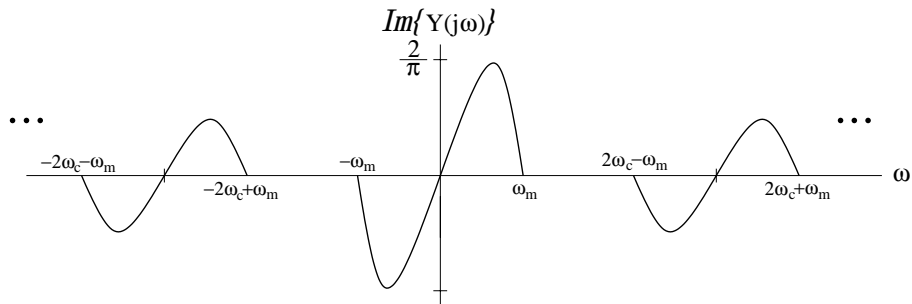
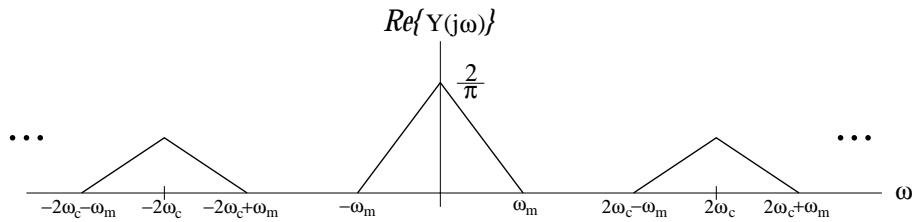

- (b) To let  $x(t) = v(t)$ , we must retain the frequency content between  $\pm\omega_m$  of  $Y(j\omega)$  and scale it properly. Therefore,  $H(j\omega)$  is a low-pass filter with cutoff frequency at  $\omega_m$  and gain  $\frac{\pi}{2}$ , as sketched below:

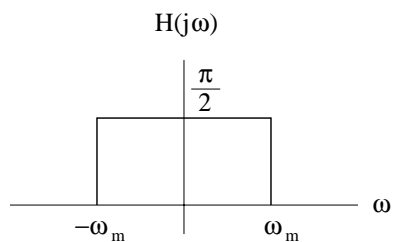

**Problem 1 (O & W 7.34)**

$X(e^{j\omega})$  has characteristics as graphed below (where  $A$  is any real number) :

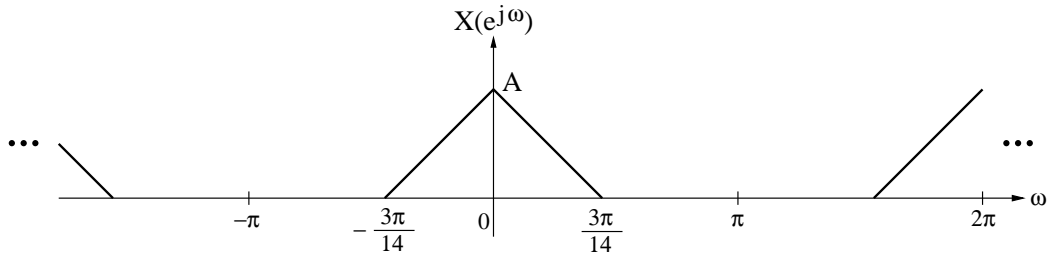

To let  $X(e^{j\omega})$  occupy the entire range between  $-\pi$  and  $\pi$ , we need to scale the spectrum from  $-\frac{3\pi}{14}$  to  $\frac{3\pi}{14}$  by a factor of  $\frac{14}{3}$ , and therefore we need to change the sampling rate by a factor of  $\frac{14}{3}$ . Since we can only upsample and downsample by integer factors, we need to upsample by a factor of 3, and then downsample by a factor of 14.

When we upsample by 3, we compress the spectrum of  $X(e^{j\omega})$  by a factor of 3, and then pass this through a low-pass filter with a gain of 3. The result is shown in the following figure:

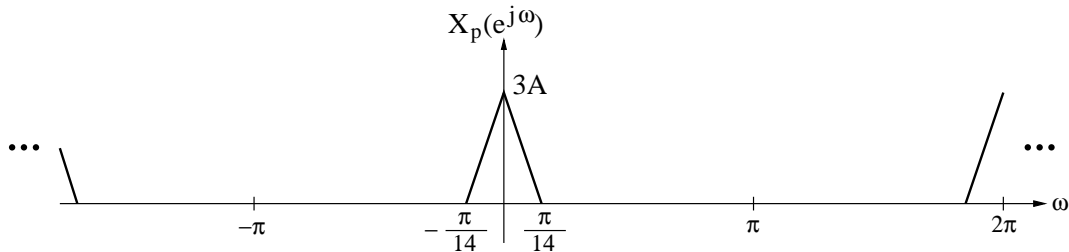

Next, when we downsample the above spectrum by 14, we expand the spectrum by a factor of 14 and scale the height by  $\frac{1}{14}$ , as graphed below:

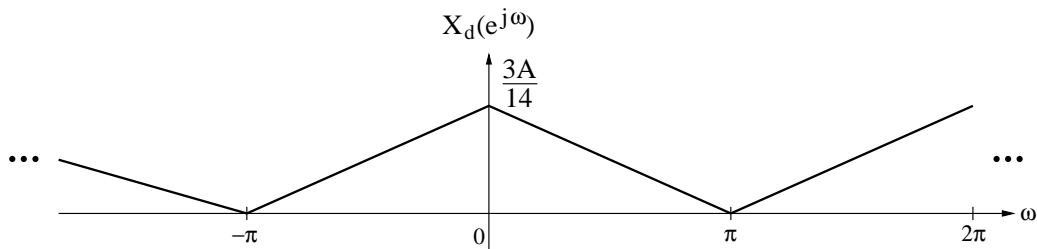

Therefore,  $L = 3$  and  $M = 14$ .

**Problem 2**

(a)  $x[n]$  is a real-valued DT signal whose DTFT for  $-\pi < \omega < \pi$  is given by

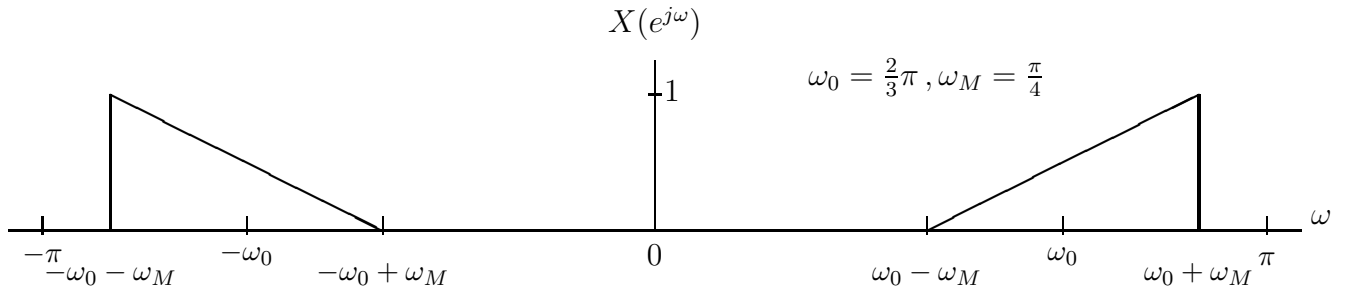

Let

$$z_c[n] = x[n] \cos[w_o n]$$

Using table 5.2 and taking Fourier transform of  $\cos[w_o n]$ ,

$$\mathcal{DTFT}\{\cos[w_o n]\} = \pi \sum_{l=-\infty}^{+\infty} \{\delta(\omega - w_o - 2\pi l) + \delta(\omega + w_o - 2\pi l)\}$$

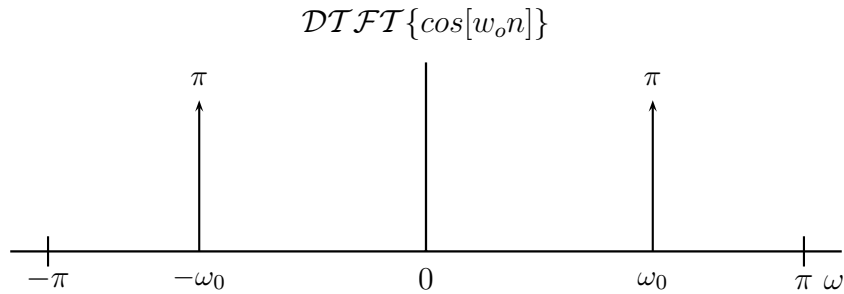

Using the multiplication property from table 5.1,  $Z_c(e^{j\omega})$  is the periodic convolution of  $X(e^{j\omega})$  and  $\mathcal{DTFT}\{\cos[w_o n]\}$  over period  $2\pi$  and then scaled by  $\frac{1}{2\pi}$ . We take one period, from  $-\pi$  to  $\pi$ , of  $\mathcal{DTFT}\{\cos[w_o n]\}$  and do regular convolution with  $X(e^{j\omega})$ . Centered at  $\omega = 0$ , we get the superposition of two  $X(e^{j\omega})$  scaled by  $\frac{1}{2}$ .  $Z_c(e^{j\omega})$  is shown below for the interval  $-\pi$  to  $\pi$ .

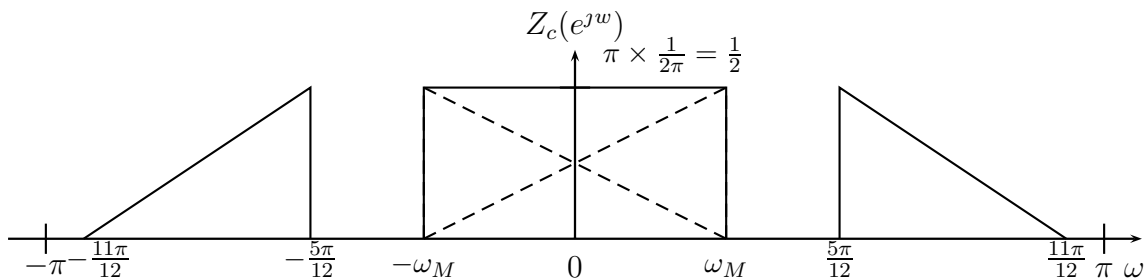

$Z_c(e^{j\omega})$  is then passed through a low-pass filter with cut-off frequency  $\omega_M$  and gain of 1. DTFT of  $x_c[n]$  is shown below.

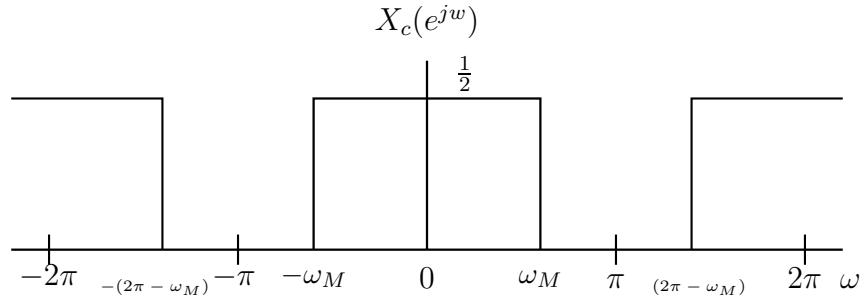

Let

$$z_s[n] = x[n] \sin[\omega_o n]$$

Using table 5.2 and taking Fourier transform of  $\sin[\omega_o n]$ ,

$$\mathcal{DTFT}\{\sin[\omega_o n]\} = \frac{\pi}{j} \sum_{l=-\infty}^{+\infty} \{\delta(\omega - \omega_o - 2\pi l) - \delta(\omega + \omega_o - 2\pi l)\}$$

We find  $Z_s(e^{j\omega})$  using the periodic convolution as before. The superposition terms centered at  $\omega = 0$  from  $X(e^{j\omega})$  (in dashed lines) are shown below. Adding the superposition terms, resulting  $Z_s(e^{j\omega})$  is shown for interval  $-\pi$  to  $\pi$ .

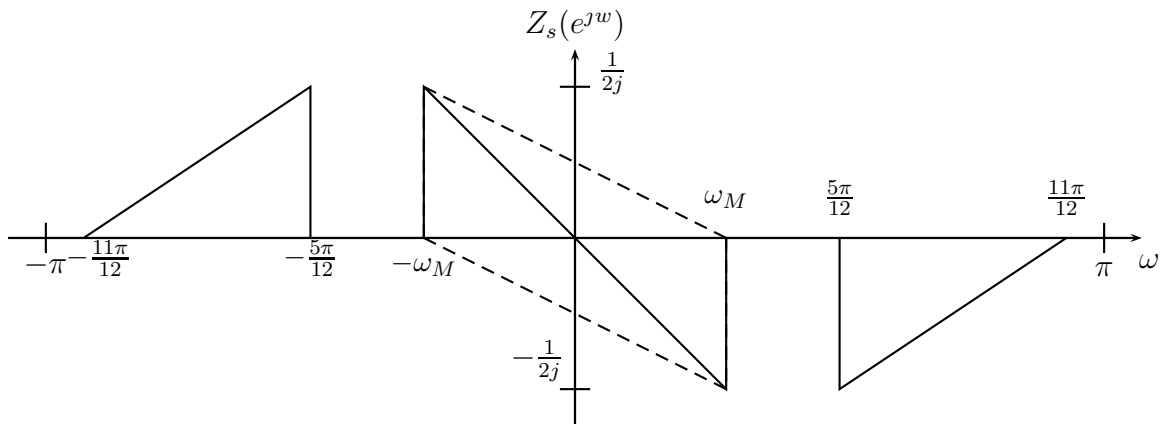

$Z_s(e^{j\omega})$  goes through the low-pass filter with cut-off frequency  $\omega_M$  and gain of 1, we find DTFT of  $x_s[n]$  as shown below.

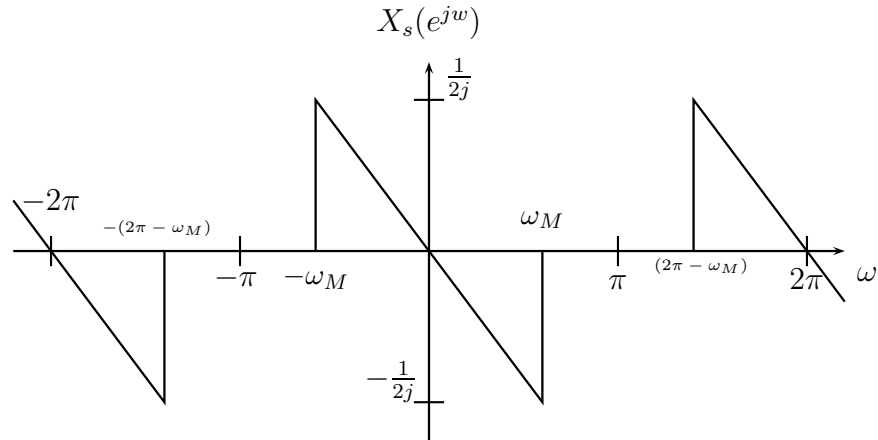

- (b) Maximum possible downsampling is achieved once the non-zero portion of one period of the discrete-time spectrum has expanded to fill the entire band from  $-\pi$  to  $\pi$ . Therefore,

$$m = \frac{\pi}{\omega_M} = \frac{\pi}{\frac{\pi}{4}} = 4$$

- (c) Following is the system diagram to recover  $x[n]$ .

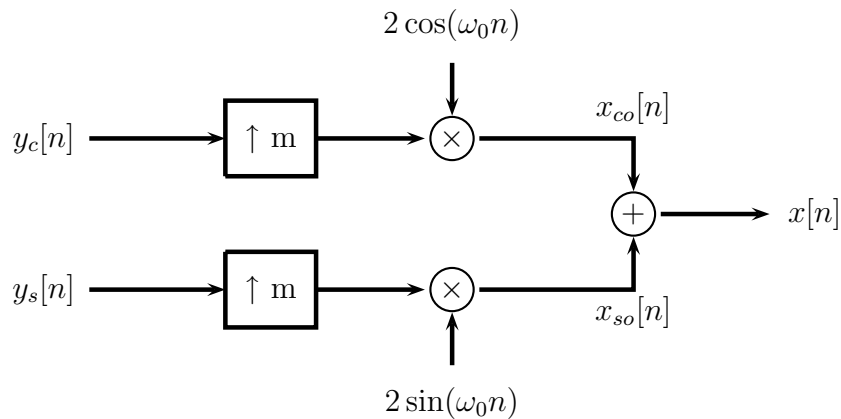

After upsampling by  $m$ , we get back  $x_c[n]$  and  $x_s[n]$  from  $y_c[n]$  and  $y_s[n]$  respectively. Note that upsampling by  $m$  has zero-insertion block (up-arrow  $m$ ) and a low-pass filter for time-domain interpolation. DTFT of  $x_c[n]$  and  $x_s[n]$  are derived in part *a*. According to the system diagram,

$$x_{co}[n] = x_c[n] \times 2 \cos[\omega_0 n]$$

Using the multiplication property and doing periodic convolution, we get  $X_{co}(e^{j\omega})$  as shown below.

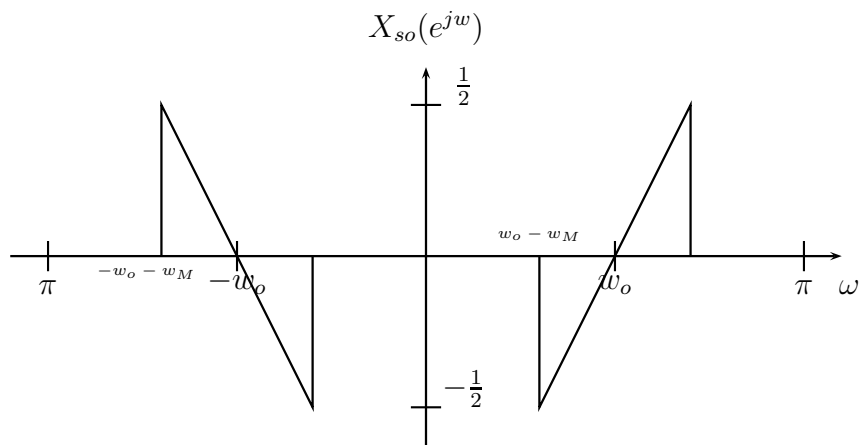
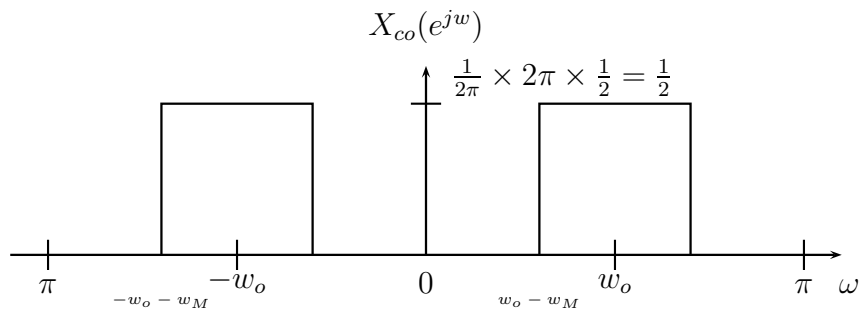

Similarly,  $x_{so}[n] = x_s[n] \times 2 \sin[w_o n]$ , and we get  $X_{so}(e^{j\omega})$  as shown in the figure.

Adding  $X_{co}(e^{j\omega})$  and  $X_{so}(e^{j\omega})$ , we get back the spectrum of  $X(e^{j\omega})$ . Thus, we recover  $x[n]$ .

### Problem 3

(a)

$$x(t) = e^{-t}u(-t) + 2e^{-2t}u(t)$$

Using Laplace transforms of elementary functions (table 9.2), we find,

$$\begin{aligned} e^{-t}u(-t) &\longleftrightarrow \frac{-1}{s+1}, & R_1 = \mathcal{R}e\{s\} < -1 \\ e^{-2t}u(t) &\longleftrightarrow \frac{1}{s+2}, & R_2 = \mathcal{R}e\{s\} > -2 \end{aligned}$$

Using the linearity property,

$$\begin{aligned} X(s) &= \frac{-1}{s+1} + \frac{2}{s+2}, & \text{ROC containing } R_1 \cap R_2 \\ &= \frac{s}{(s+1)(s+2)} & \text{ROC} = -2 < \mathcal{R}e\{s\} < -1 \end{aligned}$$

The pole-zero plot is shown below:

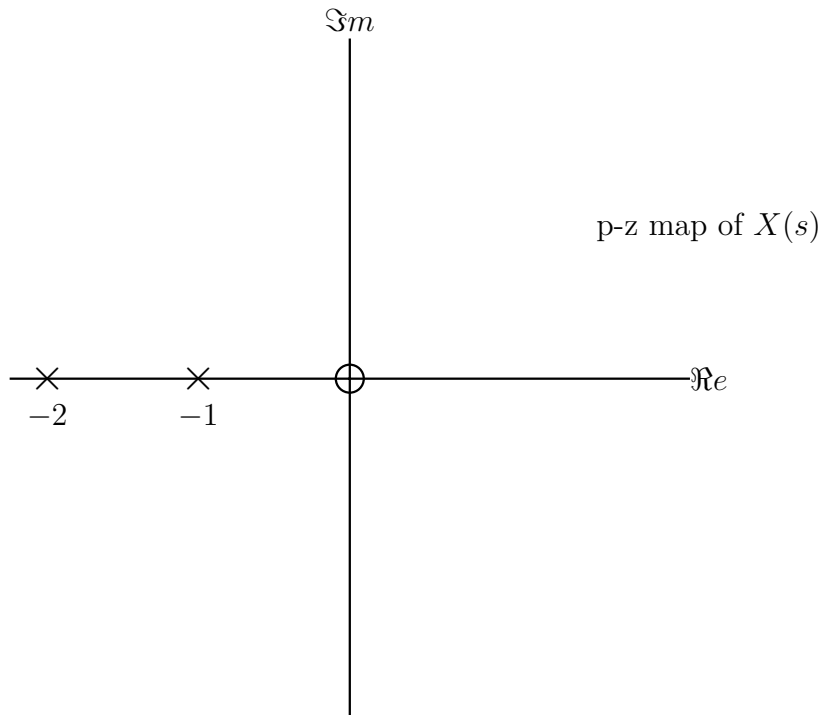

(b)

$$\begin{aligned}x(t) &= (e^t \cos t)u(-t) + u(-t) \\&= \left( e^t \left( \frac{1}{2}e^{jt} + \frac{1}{2}e^{-jt} \right) \right) u(-t) + u(-t) \\&= \frac{1}{2}e^{(1+j)t}u(-t) + \frac{1}{2}e^{(1-j)t}u(-t) + u(-t)\end{aligned}$$

Using Laplace transforms of elementary functions (table 9.2), we find,

$$\begin{aligned}e^{(1+j)t}u(-t) &\longleftrightarrow \frac{-1}{s - (1 + j)}, & R_1 = \mathcal{Re}\{s\} < 1 \\e^{(1-j)t}u(-t) &\longleftrightarrow \frac{-1}{s - (1 - j)}, & R_2 = \mathcal{Re}\{s\} < 1 \\u(-t) &\longleftrightarrow \frac{-1}{s} & R_3 = \mathcal{Re}\{s\} < 0\end{aligned}$$

Using the linearity property,

$$\begin{aligned}X(s) &= \frac{-1/2}{s - (1 + j)} + \frac{-1/2}{s - (1 - j)} + \frac{-1}{s}, & \text{ROC containing } R_1 \cap R_2 \cap R_3 \\&= \frac{-(1/2)s^2 + (1/2)s(1 - j) - (1/2)s^2 + (1/2)s(1 + j) - s^2 + 2s - 2}{s(s^2 - 2s + 2)} & \text{ROC} = \mathcal{Re}\{s\} < 0 \\&= \frac{-1(2s^2 - 3s + 2)}{s(s^2 - 2s + 2)} & \text{ROC} = \mathcal{Re}\{s\} < 0\end{aligned}$$

Solving the denominator, we see that poles are located at,

$$\begin{aligned}s &= 1 \pm j \\s &= 0\end{aligned}$$

Solving the numerator, we see that zeros are located at,

$$s = \frac{3}{4} \pm j\frac{\sqrt{7}}{4}$$

The pole-zero plot is shown below:

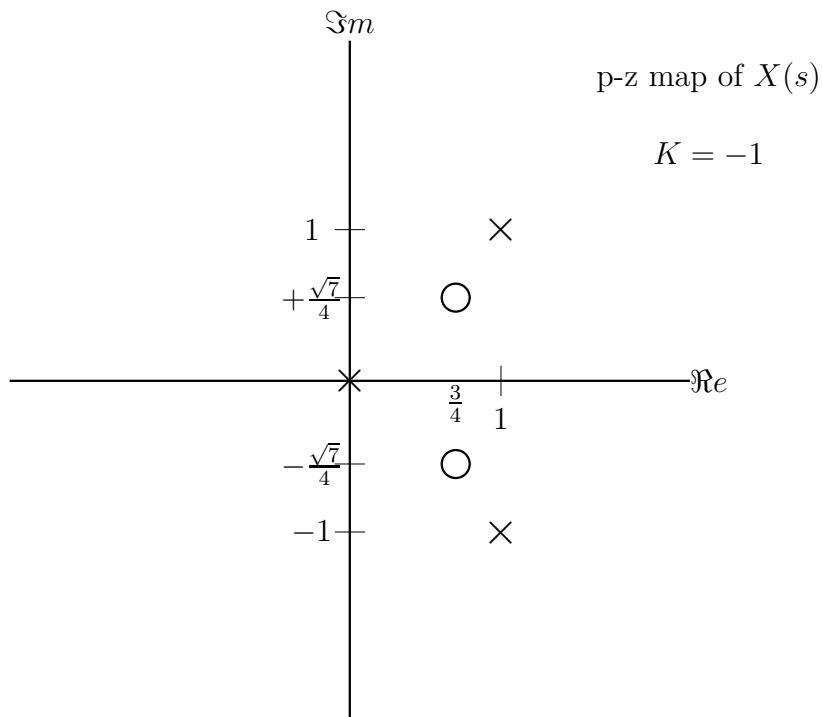

#### Problem 4

(a) We are given,

$$X(s) = \frac{s - 25}{s^2 - s - 12} = \frac{s - 25}{(s - 4)(s + 3)} \quad -3 < \mathcal{Re}\{s\} < 4$$

Using partial fraction expansion:

$$\frac{s - 25}{(s - 4)(s + 3)} = \frac{A}{s - 4} + \frac{B}{s + 3}$$

multiply both sides by  $(s - 4)$  and plug-in  $s = 4$ ,

$$\begin{aligned} \frac{s - 25}{s + 3} &= A \\ A &= -3 \end{aligned}$$

multiply both sides by  $(s + 3)$  and plug-in  $s = -3$ ,

$$\begin{aligned} \frac{s - 25}{s - 4} &= B \\ B &= 4 \end{aligned}$$

Therefore,

$$X(s) = \frac{-3}{s-4} + \frac{4}{s+3} \quad -3 < \mathcal{Re}\{s\} < 4$$

Using the table of Laplace transforms for elementary functions (table 9.2) and given ROC, we find

$$x(t) = 3e^{4t}u(-t) + 4e^{-3t}u(t)$$

(b) We are given,

$$X(s) = \frac{2s^2 + 7s + 9}{(s+2)^2} = \frac{2s^2 + 7s + 9}{s^2 + 4s + 4} \quad \mathcal{Re}\{s\} > -2$$

As the degree of the numerator is equal to that of the denominator, we need to use long division to divide the numerator by the denominator before finding the partial fraction expansion:

$$X(s) = 2 - \frac{s-1}{(s+2)^2}$$

Now we can find the partial fraction expansion of the second term on the right hand side of the equality:

$$\frac{s-1}{(s+2)^2} = \frac{A}{(s+2)^2} + \frac{B}{s+2}$$

multiply both sides by  $(s+2)^2$  and plug-in  $s = -2$ ,

$$\begin{aligned} s-1 &= A + B(s+2) \\ A &= -3 \end{aligned}$$

multiply both sides by  $(s+2)^2$ , plug-in A and  $s = 1$ ,

$$\begin{aligned} s-1 &= A + B(s+2) \\ B &= 1 \end{aligned}$$

Therefore,

$$\begin{aligned} X(s) &= 2 - \left( \frac{-3}{(s+2)^2} + \frac{1}{s+2} \right) \quad \mathcal{Re}\{s\} > -2 \\ &= 2 + \frac{3}{(s+2)^2} - \frac{1}{s+2} \quad \mathcal{Re}\{s\} > -2 \end{aligned}$$

Using the table of Laplace transforms for elementary functions (table 9.2) and given ROC, we find

$$x(t) = 2\delta(t) + 3te^{-2t}u(t) - e^{-2t}u(t)$$

**Problem 5 (O & W 9.24 (f))**

We are given  $X(s)$ .  $|X(jw)|$  for any  $w$  can be calculated as  $K \frac{bc}{ad}$  where  $K$  is any real number and  $a, b, c, d$  are vector magnitudes as shown below in the pole-zero diagram of  $X(s)$ .

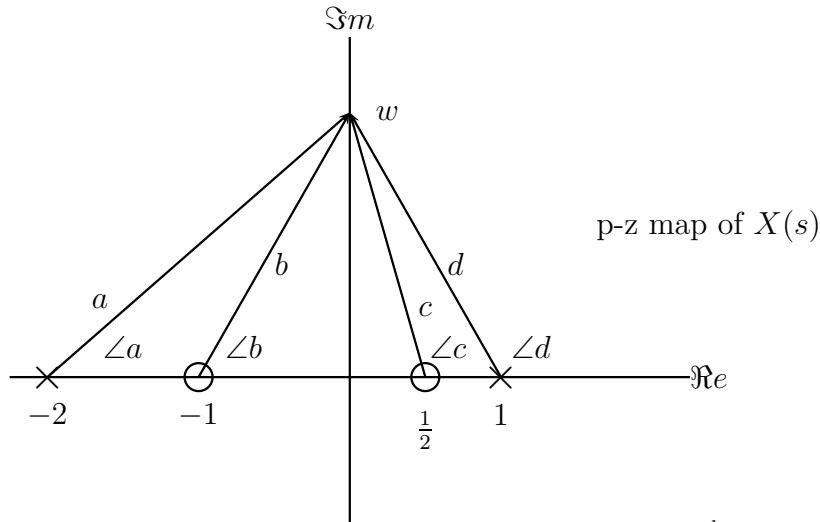

We need to find  $X_1(s)$  such that,  $|X_1(jw)| = |X(jw)| = K \frac{bc}{ad}$ , and there are no poles and zeros in the right-half plane.

Reflecting the pole (at 1 on real axis) and zero (at  $\frac{1}{2}$  on real axis) along  $iw$ -axis or imaginary axis, we can conserve the magnitude  $d$  and  $c$  from the pole and zero respectively. The resulting pole-zero diagram will be as follows:

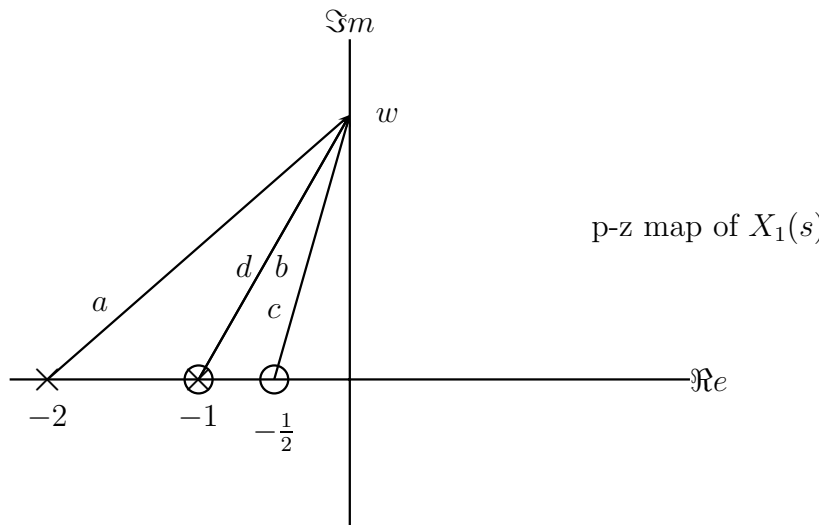

From the plot above, the pole and zero at  $-1$  will cancel each other. Therefore,

$$X_1(s) = \frac{K(s + \frac{1}{2})}{(s + 2)}$$

It is important to note that, from p-z map of  $X(s)$ , as  $b = d$ ,

$$|X(jw)| = K \frac{bc}{ad} = K \frac{c}{a} = |X_1(jw)|$$

Now, we need to find  $X_2(jw)$  such that  $\angle X_2(jw) = \angle X(jw)$  and there are no poles or zeros in the right-half plane of p-z map of  $X_2(s)$ . From the p-z map of  $X(s)$  shown on the previous page, we can write the phase,  $\angle X(jw)$ , as

$$\angle X(jw) = \angle b + \angle c - \angle a - \angle d$$

If we reflect the pole at  $s = 1$  along  $iw$ -axis, the contribution to overall phase from the reflected pole becomes  $-(\pi - \angle d) = -\pi + \angle d$ . Notice that the sign of contributed angle ( $\angle d$ ) has flipped. Now, lets convert that pole to a zero. The contribution to overall phase from the resulting zero is  $+(\pi - \angle d) = \pi - \angle d$ .

The above two operations, reflecting a pole along the  $iw$ -axis and changing it to zero, just add  $+\pi$  to overall phase. In order to keep the phase unchanged, we can multiply the resulting Laplace transform by  $-1$  as  $-1 = e^{-j\pi}$  will subtract  $\pi$  from the overall phase.

Similarly, if we reflect the zero at  $s = \frac{1}{2}$  along  $iw$ -axis, change that zero to a pole, and multiply resulting the Laplace transform with  $-1$ , the phase will remain unchanged.

Therefore,

$$\begin{aligned} X_2(s) &= K(-1)(-1) \frac{(s+1)(s+1)}{(s+2)(s+\frac{1}{2})} \\ &= \frac{K(s+1)^2}{(s+2)(s+\frac{1}{2})} \end{aligned}$$

**Problem 6 (O & W 9.26 )**

We need to find the Laplace transform of  $y(t)$  using the properties of Laplace transform. The two properties, time shifting (table 9.1 of text book) and time scaling by  $-1$  (page 686 – 687 of text book), that we will need are:

$$\begin{aligned}x(t - t_0) &\longleftrightarrow e^{-st_0} X(s) \\x(-t) &\longleftrightarrow X(-s)\end{aligned}$$

The ROC is unchanged for the time shifting property. For the time scaling by  $-1$  property, ROC is reflected about the  $j\omega$  or imaginary axis in s-plane.

$$\begin{aligned}y(t) &= x_1(t - 2) * x_2(-t + 3) \\ \text{where } x_1(t) &= e^{-2t}u(t) \\ \text{and } x_2(t) &= e^{-3t}u(t)\end{aligned}$$

taking the Laplace transform

$$\begin{aligned}x_1(t) &\longleftrightarrow \frac{1}{s + 2}, \quad \mathcal{Re}\{s\} > -2 \\x_1(t - 2) &\longleftrightarrow e^{-2s} \frac{1}{s + 2}, \quad \mathcal{Re}\{s\} > -2 \\x_2(t) &\longleftrightarrow \frac{1}{s + 3}, \quad \mathcal{Re}\{s\} > -3 \\x_2(-t) &\longleftrightarrow \frac{1}{-s + 3}, \quad \mathcal{Re}\{s\} < 3 \\x_2(-(t - 3)) &\longleftrightarrow e^{-3s} \frac{1}{-s + 3}, \quad \mathcal{Re}\{s\} < 3\end{aligned}$$

Using the convolution property of Laplace transform (table 9.1),

$$\begin{aligned}Y(s) &= X_1(s)X_2(s), \quad \text{at least } R_1 \cap R_2 \\ &= \frac{e^{-2s}}{s + 2} \times \frac{e^{-3s}}{-s + 3} \\ Y(s) &= \frac{-e^{-5s}}{s^2 - s - 6}, \quad -2 < \mathcal{Re}\{s\} < 3\end{aligned}$$