

[Show All Answers](#)
[Hide All Answers](#)

## Pipelining

★ indicates problems that have been selected for discussion in section, time permitting.

Problem 1. Consider the following combinational logic circuit constructed from 6 modules. In the diagram below, each combinational component is marked with its propagation delay in seconds; contamination delays are zero for each component.

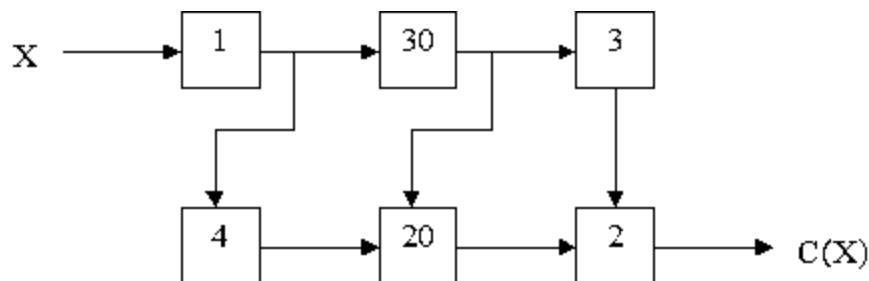

- A. ★ What is the latency and throughput of this combinational circuit?

[Hide Answer](#)

latency = longest path from X to C(X) = 1 + 30 + 20 + 2 = 53

throughput = 1/latency for combinational circuits = 1/53

- B. ★ Place the *smallest* number of ideal (zero delay, zero setup/hold time) pipeline registers in the circuit above so as to maximize its throughput. Remember to place a register on the output.

[Hide Answer](#)

We need 4 registers:

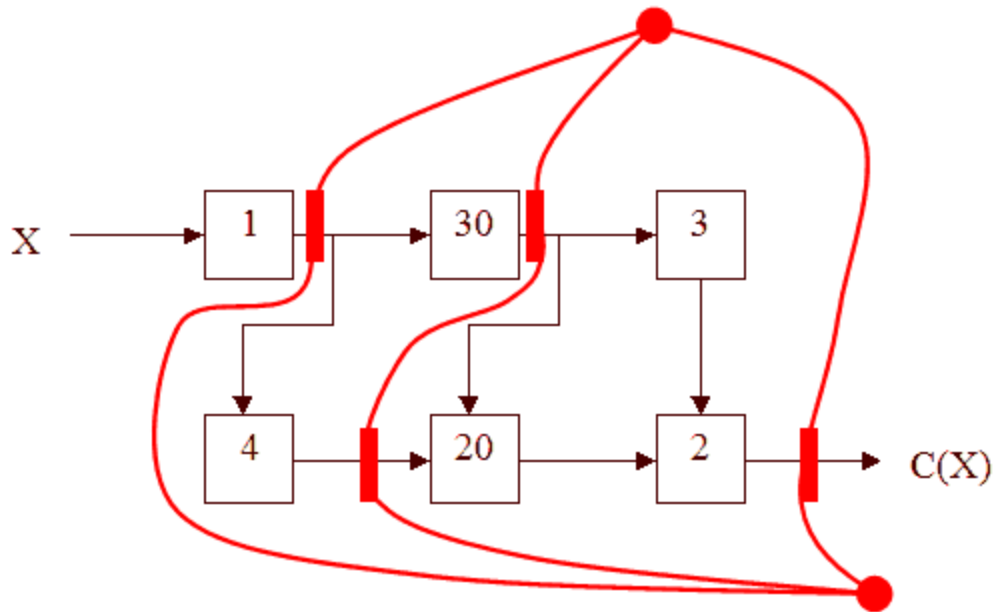

C. ★ What is the latency and throughput of your pipelined circuit?

**Hide Answer**

throughput =  $1/(\text{max pipeline stage delay}) = 1/30$   
 latency =  $(1/\text{throughput}) * (\text{number of pipeline stages}) = 30 * 3 = 90$

D. ★ We can simulate a pipelined version of a slow component by replicating the critical element and alternating inputs between the various copies. Complete the circuit diagram below to create a 2-way interleaved version of the "30" component:

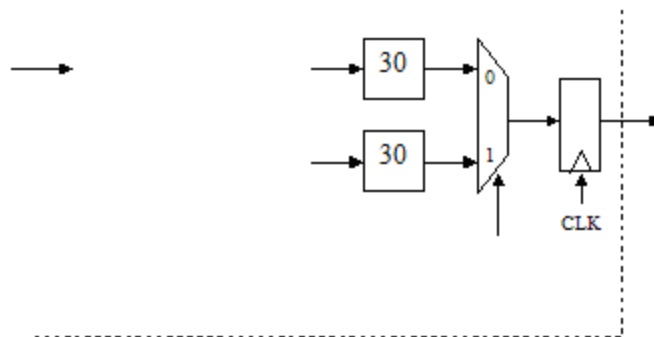

**Hide Answer**

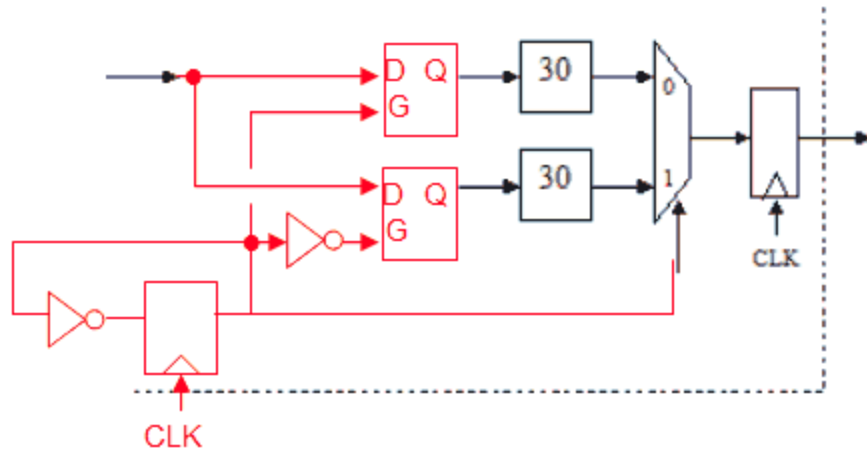

E. ★ Substituting the interleaved implementation for the original "30" module as shown in the diagram below, place the smallest number of ideal (zero delay, zero setup/hold time) pipeline registers in the circuit below so as to maximize its throughput. Remember to place a register on the output. (Draw the pipeline registers in the diagram below.)

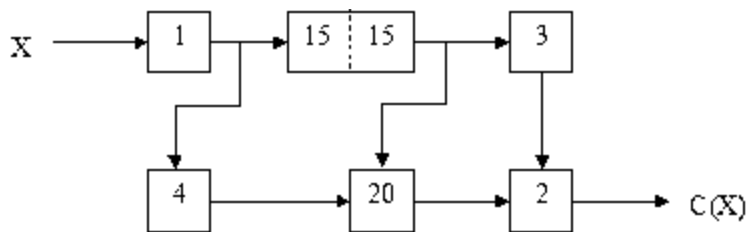

Hide Answer

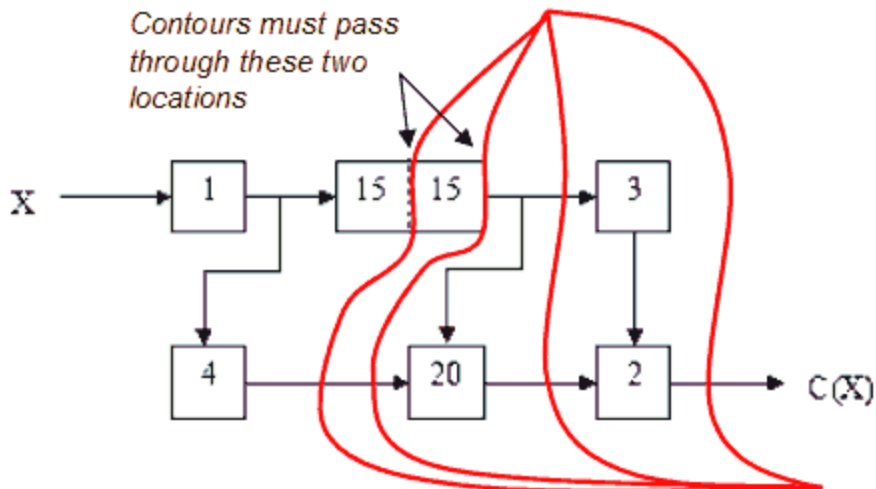

F. ★ What is the latency and throughput of your newly pipelined circuit?

Hide Answer

throughput =  $1/(\text{max pipeline stage delay}) = 1/20$

$$\text{latency} = (1/\text{throughput}) * (\text{number of pipeline stages}) = 20 * 4 = 80$$

G. ★ In general, if we take a combinational circuit and pipeline it using ideal (zero delay, zero setup/hold time) registers, which one of the following statements best describes the resulting change in the circuit's latency and throughput:

- A. The throughput may improve but the latency definitely does not.
- B. Both the throughput and latency may improve.
- C. The throughput definitely improves and the latency definitely gets worse.
- D. The latency may improve but the throughput definitely does not.
- E. The throughput definitely improves and the latency definitely does not.

**Hide Answer**

A.

Problem 2. Partial Products, Inc., has hired you as its vice president in charge of marketing. Your immediate task is to determine the sale prices of three newly announced multiplier modules. The top-of-the-line Cooker is a pipelined multiplier. The Sizzler is a combinational multiplier. The Grunter is a slower sequential multiplier. Their performance figures are as follows (T is some constant time interval):

	Throughput	Latency
Cooker	1/T	5T
Sizzler	1/4T	4T
Grunter	1/32T	32T

Customers follow a single principle: Buy the cheapest combination of hardware that meets my performance requirements. These requirements may be specified as a maximum allowable latency time, a minimum acceptable throughput, or some combination of these. Customers are willing to try any paralleled or pipelined configuration of multipliers in an attempt to achieve the requisite performance. You may neglect the cost (both financial and as a decrease in performance) of any routing, latching, or other hardware needed to construct a configuration. Concentrate only on the inherent capabilities of the arrangement of multipliers itself.

It has been decided that the Cooker will sell for \$1000. The following questions deal with determining the selling prices of Sizzlers and Grunters.

- A. ★ How much can you charge for Sizzlers and still sell any? That is, is there some price for Sizzlers above which any performance demands that could be met by a Sizzler could also be met by some combination of Cookers costing less? If there is no such maximum price, indicate a performance requirement that could be met by a Sizzler but not by any combination of Cookers. If there is a maximum selling price, give the price and explain your reasoning.

**Hide Answer**

If there is a performance requirement for the latency to be  $\leq 4T$ , then there is no combination of Cookers that will meet this performance requirement. So it is in theory possible to sell some Sizzlers at any price. Using multiple Cookers can further

improve the overall multiplier throughput, but their latency cannot be shortened.

- B. ★ How little can you charge for Sizzlers and still sell any Cookers? In other words, is there a price for the Sizzler below which every customer would prefer to buy Sizzlers rather than a Cooker? Give and explain your answer, as above.

**Hide Answer**

The minimum price for a Sizzler is \$250.01 if we want to continue to sell Cookers. If the price of a Sizzler is less than that, 4 Sizzlers could be used in parallel to achieve the same throughput as a Cooker with a better latency in the bargain.

- C. ★ Is there a maximum price for the Grunter above which every customer would prefer to buy Cookers instead? As before, give the price, if it exists, and explain your reasoning in either case.

**Hide Answer**

The maximum price for the Grunter is \$999.99 since for applications that can accept long latencies ( $\geq 32T$ ) it's worth buying a Grunter if it saves any money at all.

- D. ★ Is there a minimum price for the Grunter below which every customer would prefer to buy Grunters rather than a Cooker? Once again, give the price, if it exists, and explain your reasoning in either case.

**Hide Answer**

There is no minimum price for a Grunter that would cause every customer to buy Grunters instead of Cookers. The latency of the Grunter will always be  $32T$ , so when performance requirements demand latencies  $< 32T$ , Grunters won't do the job.

- E. Suppose that, as a customer, you have an application in which 64 pairs of numbers appear all at once, and their 64 products must be generated in as short a time as practicable. You have \$1000 to spend. At what price would you consider using Sizzlers? At what price would you consider using Grunters?

**Hide Answer**

Sizzlers will be considered when they cost \$250 or less. Grunters may be considered when they cost \$124.93 or less. To see this, consider the case when Sizzlers cost \$125.01. Buying seven Sizzlers would yield a latency of  $40T$  at a cost of \$875.07. The customer cannot afford another Sizzler, but adding a single Grunter for \$124.93 will reduce the latency to  $36T$ . All optimal configurations are explored below:

Configuration	Latency	Used when
1 Cooker	68T	$P_S > \$250, P_G > \$31.25$
4 Sizzlers	64T	$\$1000 \geq P_S > \$250 - P_G$
32 Grunters		$\$31.25 \geq P_G > \$15.62$
4 Sizzlers and 4 Grunters	60T	$\$250 \geq P_S + P_G > P_S + 2P_G, P_S > \$200$
4 Sizzlers and 8 Grunters	56T	$\$250 \geq P_S + 2P_G > P_S + 3P_G, P_S > \$200$
5 Sizzlers	52T	$\$200 \geq P_S > \$166, 12P_G \geq P_S,$ $5P_S + 4P_G > \$1000$
4 Sizzlers and 12 Grunters		$\$250 \geq P_S + 3P_G, P_S > 12P_G > \$187.50,$ $5P_S + 4P_G > \$1000$
5 Sizzlers and 4 Grunters	48T	$\$1000 \geq 5P_S + 4P_G, 5P_S + 9P_G > \$1000$
6 Sizzlers	44T	$\$166.66 \geq P_S > \$142.85, 9P_G \geq P_S,$ $6P_S + 4P_G > \$1000$
5 Sizzlers and 9 Grunters		$\$1000 \geq 5P_S + 9P_G, P_S > 9P_G > \$140.62,$ $6P_S + 4P_G > \$1000, P_S > \$142.85$
7 Sizzlers	40T	$\$142.85 \geq P_S > \$125, 4P_G \geq P_S,$ $7P_S + 1P_G \geq \$1000$
6 Sizzlers and 4 Grunters		$7P_S + 1P_G > \$1000 \geq 6P_S + 4P_G,$ $P_S > 4P_G > \$60, P_S > \$125$
7 Sizzlers and 1 Grunter	36T	$\$1000 \geq 7P_S + P_G, P_S > \$125,$ $P_G > \$15.62$
8 Sizzlers	32T	$\$125 \geq P_S > \$100, 8P_G \geq P_S$
64 Grunters		$\$15.62 \geq P_G, P_S > 8P_G, P_S > \$100$
10 Sizzlers	28T	$\$100 \geq P_S > \$90.90$
11 Sizzlers	24T	$\$90.90 \geq P_S > \$76.92$
13 Sizzlers	20T	$\$76.92 \geq P_S > \$62.50$
16 Sizzlers	16T	$\$62.50 \geq P_S > \$45.45$
22 Sizzlers	12T	$\$45.45 \geq P_S > \$31.25$
32 Sizzlers	8T	$\$31.25 \geq P_S > \$15.62$
64 Sizzlers	4T	$\$15.62 \geq P_S$

**Problem 3.** Peculiar Peripherals, Inc. Builds a combinational encryption device constructed of nine modules as follows:

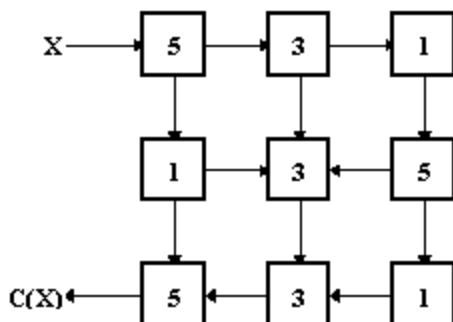

The device takes an integer value  $X$  and computes an encrypted version  $C(X)$ . In the diagram above each combinational component is marked with its propagation delay in microseconds; contamination delays are zero for each component.

- A. What is the latency and throughput of the combinational encryption device?

**Hide Answer**

Latency =  $5 + 3 + 1 + 5 + 3 + 3 + 5 = 25\mu\text{s}$ . Throughput =  $1/25\mu\text{s}$ .

- B. Redraw the diagram marking the locations for ideal (zero-delay) registers that will pipeline the device for maximal throughput. Ensure a register at the output and use the minimum number of registers necessary.

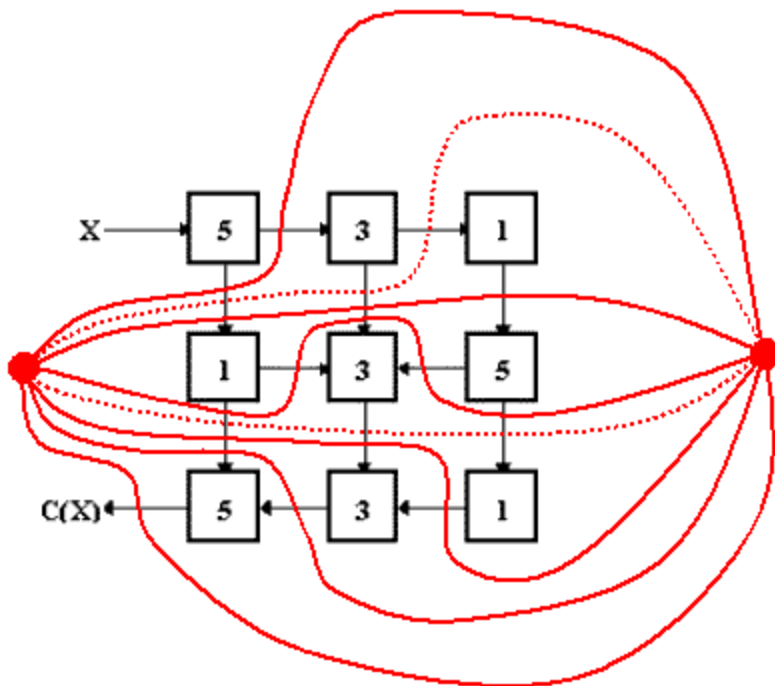
**Hide Answer**

We can remove some of the registers implied by contours (eg, those shown with dotted lines) without decreasing the throughput. There are several equivalent variations of this diagram.

- C. Give the latency and throughput of your pipelined version. Again assume ideal registers.

**Hide Answer**

There are six registers in each input-output path and the clock period is 5, so latency = 30 and throughput =  $1/5$ .

Problem 4. Consider the following combinational encryption device constructed from six modules:

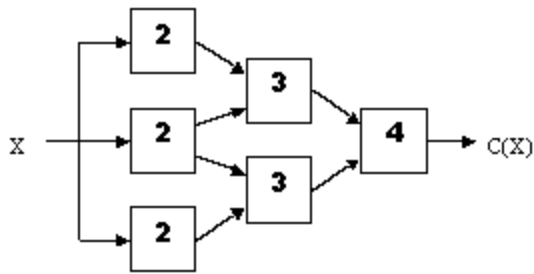

The device takes an integer value,  $X$ , and computes an encrypted version  $C(X)$ . In the diagram above, each combinational component is marked with its propagation delay in seconds; contamination delays are zero for each component.

In answering the following questions assume that registers added to the circuit introduce no additional delays (i.e., the registers have a contamination and propagation delay of zero, as well as zero setup and hold times). Any modifications must result in a circuit that obeys our rules for a well-formed pipeline and that computes the same results as the combinational circuit above. Remember that our pipeline convention requires that every pipeline stage has a register on its output.

When answering the questions below, if you add a register to one of the arrows in the diagram, count it as a single register. For example, it takes two registers to pipeline both inputs to the rightmost module (the one with latency 4).

- A. What is the latency of the combinational encryption device?

**Hide Answer**

Latency = delay along longest path from input to output =  $2 + 3 + 4 = 9$ .

- B. If we want to increase the throughput of the encryption device, what is the minimum number of registers we need to add?

**Hide Answer**

Three. Playing by our pipelining rules, we always add a register to the output. The increase the throughput we need to add other register that bisect the circuit. The cheapest place to do this is just before the "4" module, requiring two additional registers.

- C. If we are required to add exactly 5 registers, what is the best throughput we can achieve?

**Hide Answer**

The best throughput we can achieve with 5 registers is  $1/5$ : place 3 (!) registers on the output and two registers on the arcs leading to the "4" module. If we use 4 registers to divide the circuit between the "2" and "3" modules, the resulting throughput is  $1/7$ .

- D. If we can add as many registers as we like, is there an upper bound on the

throughput we can achieve?

**Hide Answer**

Yes: 1/4, because the best we can do by just adding registers is to segregate the "4" module into its own pipeline stage.

- E. If we can add as many registers as we like, is there a lower bound on the latency we can achieve?

**Hide Answer**

Lower bound on latency = 9. We can never make the latency less by adding pipeline registers; usually the latency increases.

**Problem 5.** Consider the following pipelined circuit: The number written on top of each combinational element indicates its propagation delay in nanoseconds. Assume that the pipeline registers shown are ideal (they have a propagation delay, contamination delay, hold-time and a set-up time of 0 ns).

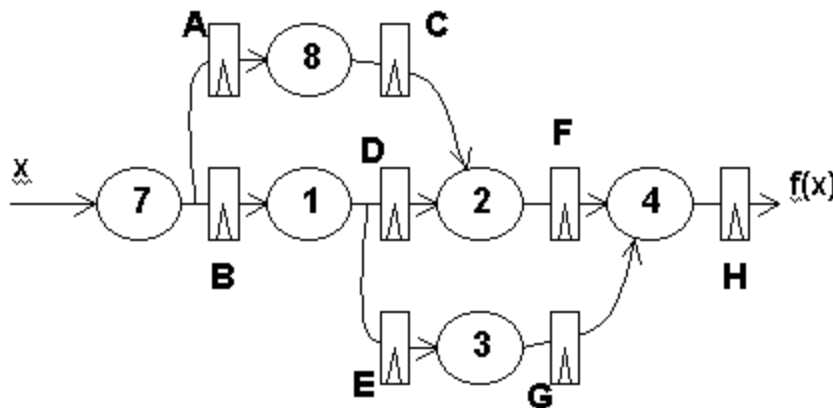

- A. What is the minimum clock period for which we can expect the given circuit to operate correctly?

**Hide Answer**

8ns since we have to leave time for the logic between registers A and C to do its stuff.

- B. What is the minimum latency of the circuit as shown?

**Hide Answer**

32ns = 4 pipeline stages at 8ns clock period.

- C. If the registers labeled F and G are removed, describe the resulting circuit's behavior.

**Hide Answer**

Removing F and G combines the last two pipeline stages into a single pipeline stage. The latency improves to 24ns and the throughput stays 1/8ns.

- D. Assume you were to redesign the pipelining of the given circuit to achieve the maximum possible throughput with minimum latency. What is the minimum number of pipeline registers required (including register H)?

**Hide Answer**

We can do it with four registers if we allow ourselves to use only a single register on values that go to multiple inputs:

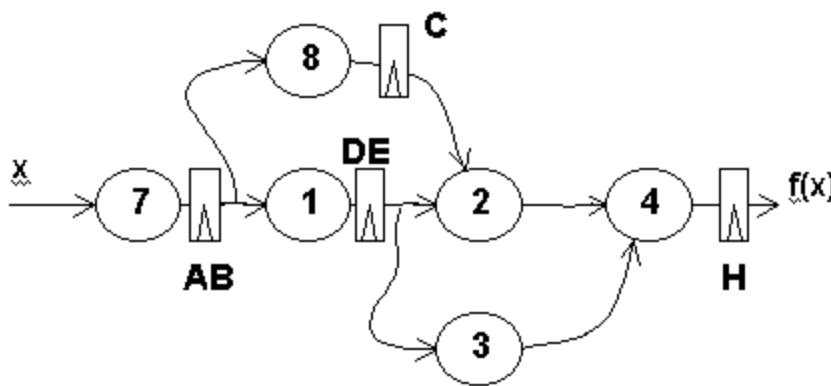

- E. If the pipeline registers in the given circuit were all replaced with non-ideal pipeline registers having propagation delays of 2 ns, set-up times of 1 ns, and hold times of 0 ns, what would be the maximum throughput achievable with the supplied six combinational modules?

**Hide Answer**

The clock period would be set by the delay of the pipeline stage containing the "8" module:  $t_{CLK} = t_{PD,REG} + 8 + t_{S,REG} = 11ns$ . So the throughput would be 1/11ns.

- F. If the pipeline registers in the given circuit were all replaced with non-ideal pipeline registers having propagation delays of 2 ns, set-up times of 1 ns, and hold times of 0 ns, how long before the system clock must the input x be set-up to assure that the pipeline registers A and B do not go into a metastable state?

**Hide Answer**

$t_{S,X} = 7 + t_{S,REG} = 8ns$ .

- G. Suppose that a second output,  $g(x)$ , is desired from the given circuit. It provides the partial result present at the output of the pipeline register labeled C. If we wish the outputs  $f(x)$  and  $g(x)$  to correspond to the same input after each clock, how many new pipeline registers should be added to the circuit shown?

**Hide Answer**

We need to add 2 new registers:

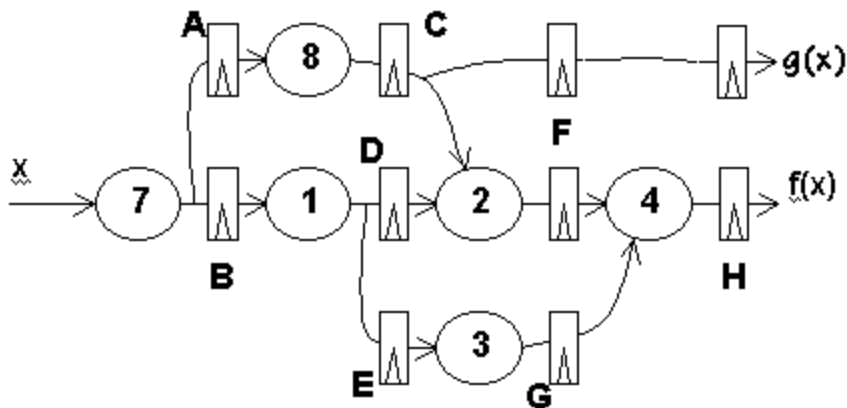

**Problem 6.** You have the task of pipelining a combinational circuit consisting entirely of 2-input NAND gates with 1ns propagation delay by adding registers having  $t_S=1\text{ns}$ ,  $t_H=1\text{ns}$ ,  $t_{PD}=2\text{ns}$  and  $t_{CD}=1\text{ns}$ . The propagation delay of the original combinational circuit is 20 ns.

- A. Assuming you add the minimum number of registers to pipeline the circuit for maximal throughput, what is the latency of the resulting pipelined circuit?

**Hide Answer**

If the combinational circuit has a  $t_{PD}$  of 20ns when built from 1ns components, there must be an input-output path involving 20 components. To get maximal throughput, we'd place each component in its own pipeline stage for a total of 20 stages. Each stage requires  $t_{PD,REG} + t_{PD,NAND} + t_S,REG = 2 + 1 + 1 = 4\text{ns}$  to do its job. So the latency of the circuit pipelined for maximal throughput is 80ns.

**Problem 7.** Circuits Maximus, Inc. makes circuits which compute the maximum of two unsigned binary numbers. They are constructed using combinational 1-bit Maximizes modules which are cascaded to deal with longer words, as shown below:

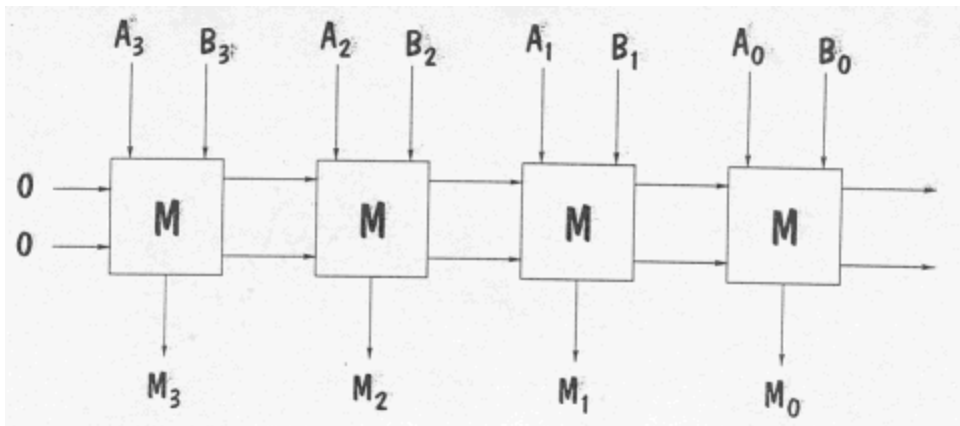

This diagram shows a 4-bit Maximizer chain which computes at the  $M$  outputs the larger of the  $A$  or  $B$  input operands. Each Maximizer module takes the  $i$ th bit of each of two binary operands,  $A$  and  $B$ , as well as comparison outputs from the next higher-order Maximizer module in a chain, as shown below:

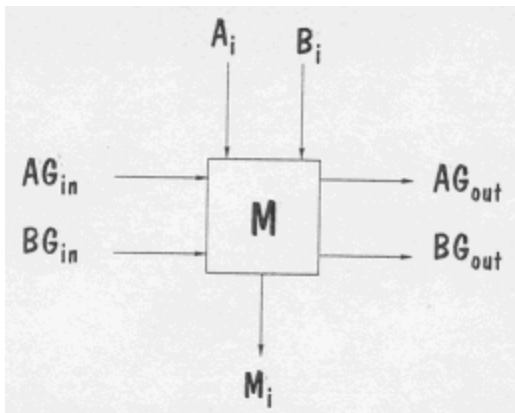

A "1" on either of the inputs  $AG_{in}$  and  $BG_{in}$  from the next higher-order module signals that  $A$  or  $B$ , respectively, is greater; both inputs are zero if the higher-order bits are identical. The  $M$  module computes the output values  $AG_{out}$  and  $BG_{out}$  from  $AG_{in}$ ,  $BG_{in}$ ,  $A_i$  and  $B_i$  and sends these output values to the next lower-order  $M$  module. It also passes either  $A_i$  or  $B_i$  as the  $M_i$  output, denoting the  $i$ th bit of the maximum of  $A$  and  $B$ .

An implementation has been developed for the  $M$  module that has 10ns propagation delay and a 2ns contamination delay.

- A. Assuming that use of ideal registers, mark the previous diagram to show a 4-bit Maximizer pipelined for maximum throughput.

[Hide Answer](#)

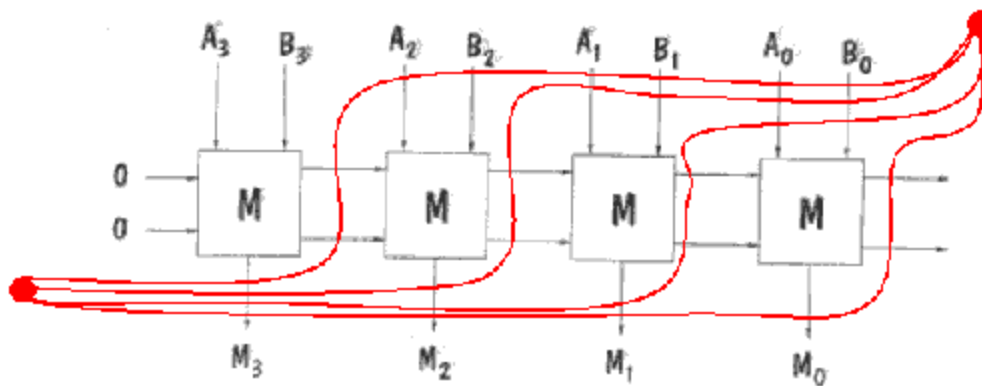

- B. To compute the maximum value of  $N$  inputs ( $N > 2$ ), the following structure is proposed:

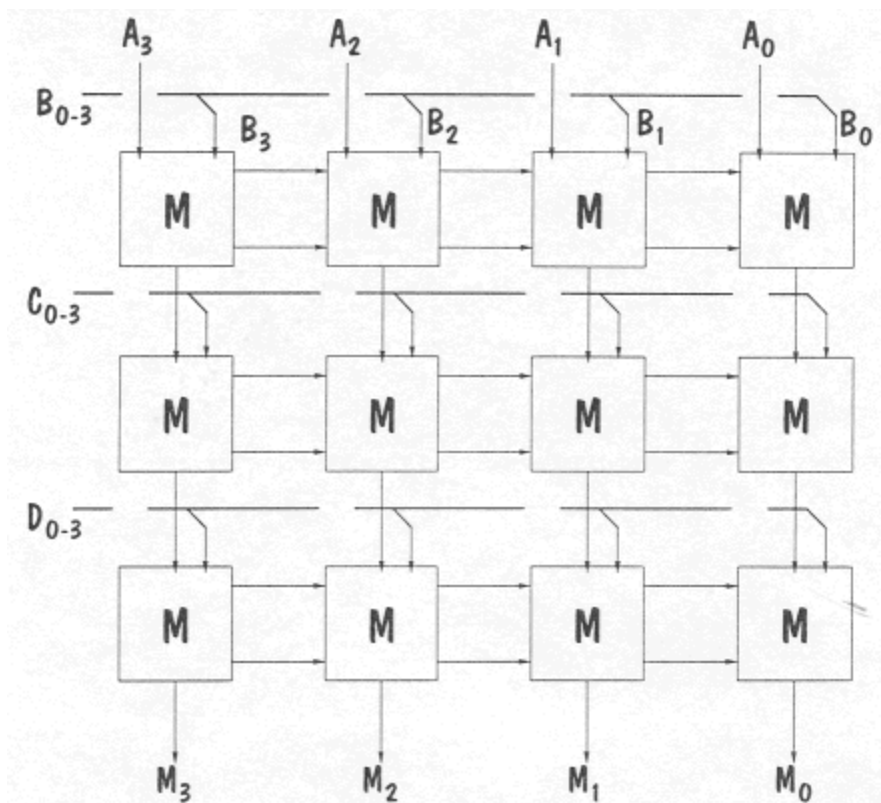

In this circuit, the maximum of four 4-bit unsigned numbers is computed and appears at the output  $M_3..M_0$ . What is the latency and throughput of this combinational circuit, assuming that each  $M$  module has a propagation delay of 10ns?

**Hide Answer**

The longest path from inputs to outputs passes through 6  $M$  modules, so the latency is 60 and the throughput is  $1/60$ .

- C. Show how this circuit can be pipelined from maximum throughput using a minimum number of pipeline stages. Remember to include a register at each output.

**Hide Answer**

The solution below uses a different technique for pipelining a circuit. Start by labeling each module with its maximum "distance" from the inputs, i.e., the largest number of components that have to be traversed on some path from the inputs to the module in question. Label all outputs with the length (in modules) of the longest path from input to output label each input with "0". The number of pipeline registers required on each wire is the difference between the label at the start of the arrow and the end of the arrow.

A common mistake: forgetting to add the necessary pipeline registers on the input and output arrows.

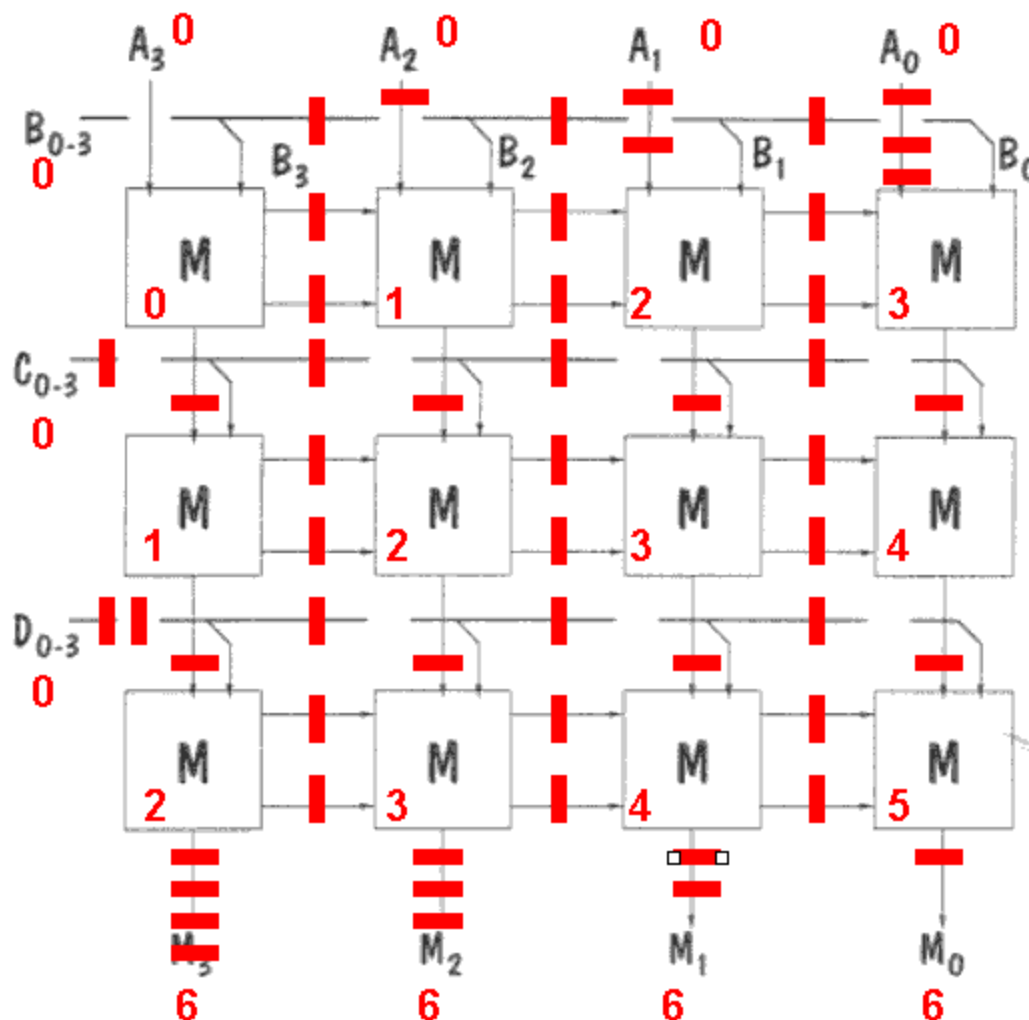

Problem 8. The following combinational circuit takes a single input and produces a visual output by lighting the light on the center component module.

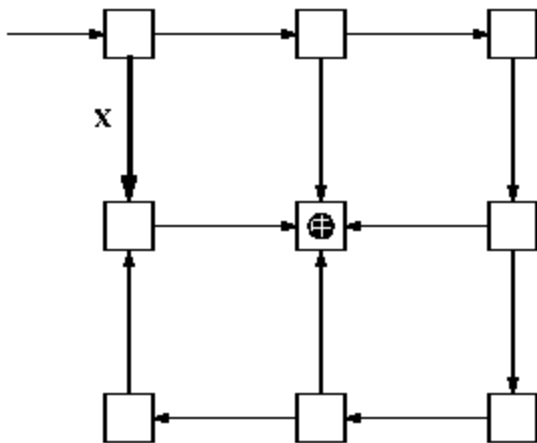

Consider the result of pipelining the above circuit for maximum throughput, using the minimum number of registers necessary. The result would be a pipeline such that input asserted during clock period  $I$  produces the proper output on the light during clock period  $I+K$  (we want minimal  $K$  which gives maximal throughput).

- A. How many registers should appear on the bold wire (marked X) in the pipelined version of the above circuit?

**Hide Answer**

Using the pipelining technique described in the previous problem, we can see from the labels that 7 registers would be required on the wire marked X:

