

6.241: Dynamic Systems—Fall 2003

HOMEWORK 12 SOLUTIONS

---

**Exercise 25.2 a)** Given:

$$H_1(s) = \frac{s+f}{(s+4)^3} = \frac{s+f}{s^3+12s^2+48s+64}, \quad H_2(s) = \frac{1}{s-2}.$$

Thus the state-space realizations in controller canonical form for  $H_1(s)$  and  $H_2(s)$  are :

$$A_1 = \begin{pmatrix} -12 & -48 & -64 \\ 1 & 0 & 0 \\ 0 & 1 & 0 \end{pmatrix}, \quad B_1 = \begin{pmatrix} 1 \\ 0 \\ 0 \end{pmatrix}, \quad C_1 = (0 \quad 1 \quad f), \quad D_1 = 0,$$

and

$$A_2 = 2, \quad B_2 = 1, \quad C_2 = 1, \quad D_2 = 0.$$

Since  $f$  is not included in the controllability matrix for  $H_1(s)$  with this realization, the controllability, which is equivalent to reachability for CT cases, the controllability is independent of the value of  $f$ . Thus, check the rank of the controllability matrix:

$$\begin{aligned} \text{rank}(\mathcal{C}) &= \text{rank} \begin{pmatrix} 1 & -12 & 96 \\ 0 & 1 & -12 \\ 0 & 0 & 1 \end{pmatrix} \\ &= 3. \end{aligned}$$

Thus, the system with this realization is controllable. On the other hand, the observability matrix  $\mathcal{O}$  for  $H_1(s)$  contains  $f$  in it as follows:

$$\mathcal{O} = \begin{pmatrix} 0 & 1 & f \\ 1 & f & 0 \\ -12+f & -48 & -60 \end{pmatrix}.$$

Thus, when  $f = 4$ ,  $\mathcal{O}$  decreases its rank from 3 to 2.

Now, let's consider the state-space realization in observer canonical form for  $H_1(s)$ . It can be expressed as follows:

$$A_1 = \begin{pmatrix} 0 & 0 & -64 \\ 1 & 0 & -48 \\ 0 & 1 & -12 \end{pmatrix}, \quad B_1 = \begin{pmatrix} f \\ 1 \\ 0 \end{pmatrix}, \quad C_1 = (0 \quad 0 \quad 1), \quad D_1 = 0.$$

Since  $C_1$  does not contain  $f$ , the observability is independent of the value  $f$ . Thus check the rank of the observability matrix:

$$\begin{aligned} \text{rank}(\mathcal{O}) &= \text{rank} \begin{pmatrix} 0 & 0 & 1 \\ 0 & 1 & -12 \\ 1 & -12 & 96 \end{pmatrix} \\ &= 3. \end{aligned}$$

Thus thus the system with this realization is observable.  
 On the other hand, the controllability matrix contains  $f$  in it as follows:

$$\mathcal{C} = \begin{pmatrix} f & 0 & -64 \\ 1 & f & -48 \\ 0 & 1 & f - 12 \end{pmatrix}.$$

Thus, again when  $f = 4$ ,  $\mathcal{C}$  decreases its rank from 3 to 2.

b) Let  $H(s)$  be the cascaded system,  $H_2(s)H_1(s)$ . Then, the augmented system  $H(s)$  has the following state-space representation:

$$\begin{cases} \begin{pmatrix} \dot{x}_1 \\ \dot{x}_2 \end{pmatrix} = \begin{pmatrix} A_1 & 0 \\ B_2 C_1 & A_2 \end{pmatrix} \begin{pmatrix} x_1 \\ x_2 \end{pmatrix} + \begin{pmatrix} B_1 \\ 0 \end{pmatrix} u \\ y = \begin{pmatrix} 0 & C_2 \end{pmatrix} \begin{pmatrix} x_1 \\ x_2 \end{pmatrix} \end{cases}$$

$$\begin{cases} \dot{\underline{x}} = \begin{pmatrix} -12 & -48 & -64 & 0 \\ 1 & 0 & 0 & 0 \\ 0 & 1 & 0 & 0 \\ 0 & 1 & f & 2 \end{pmatrix} \underline{x} + \begin{pmatrix} 1 \\ 0 \\ 0 \\ 0 \end{pmatrix} u \\ y = \begin{pmatrix} 0 & 0 & 0 & 1 \end{pmatrix} \underline{x} \end{cases}$$

$$\rightarrow \begin{cases} \dot{x} = Ax + Bu \\ y = Cx. \end{cases}$$

Here, we use  $A_1$ ,  $B_1$ , and  $C_1$  from the controller canonical form obtained in a). Since matrix  $A$  has zero block in its upper triangle, the eigenvalues of the cascaded system are ones of  $A_1$  and  $A_2$ , i.e.,  $-4, -4, -4$ , and  $2$ . Thus the cascaded system is not asymptotically stable. Since  $C_1$  is not included in the eigenvalue computation for  $A$ , the stability does not depend on the value of  $f$ .

The controllability matrix  $\mathcal{C}$  for  $H(s)$  is

$$\begin{aligned} \mathcal{C} &= ( B \ AB \ A^2 B \ A^3 B ) \\ &= \begin{pmatrix} 1 & -12 & 12^2 - 48 & -12^3 + 48 * 12 * 2 - 64 \\ 0 & 1 & -12 & 12^2 - 48 \\ 0 & 0 & 1 & -12 \\ 0 & 0 & 1 & -12 + f + 2 \end{pmatrix}, \end{aligned}$$

which decreases its rank from 4 to 3 when  $f = -2$ . On the other hand, the observability matrix  $\mathcal{O}$  for  $H(s)$  is

$$\mathcal{O} = \begin{pmatrix} C \\ CA \\ CA^2 \\ CA^3 \end{pmatrix} = \begin{pmatrix} 0 & 0 & 0 & 1 \\ 0 & 1 & f & 2 \\ 1 & f+2 & 2f & 4 \\ -12+f+2 & -48+2f+4 & -64+4f & 8 \end{pmatrix},$$

thus the choice of  $f = 4$ ,  $\mathcal{O}$  drops its rank from full rank to 3. Thus the cascaded system is unobservable at  $f = 4$ .

It can be seen immediately that  $f = 2$  case corresponds to unstable pole-zero cancellation. Thus, for  $f = 2$ , the cascaded system is BIBO stable, but is not asymptotically stable due to the unstable pole-zero cancellation.

**Exercise 25.5** a) Given :

$$H(s) = \begin{pmatrix} \frac{s}{(s-1)^2} & \frac{1}{s-1} \\ \frac{-6}{(s-1)(s+3)} & \frac{1}{s+3} \end{pmatrix}.$$

A realization of the system is given in the block diagram below:

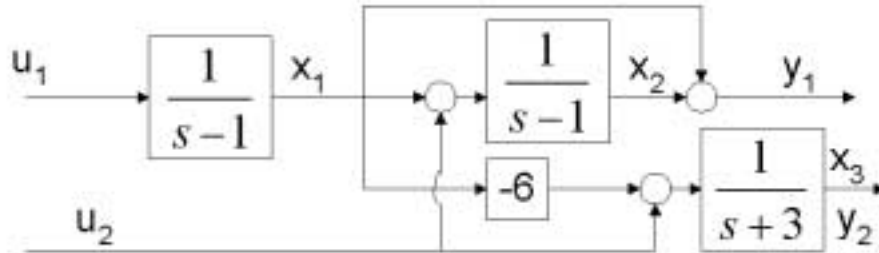

Figure 1: Block Diagram

State equations

$$\begin{pmatrix} \dot{x}_1 \\ \dot{x}_2 \\ \dot{x}_3 \end{pmatrix} = \underbrace{\begin{pmatrix} 1 & 0 & 0 \\ 1 & 1 & 0 \\ -6 & 0 & -3 \end{pmatrix}}_A \begin{pmatrix} x_1 \\ x_2 \\ x_3 \end{pmatrix} + \underbrace{\begin{pmatrix} 1 & 0 \\ 0 & 1 \\ 0 & 1 \end{pmatrix}}_B \begin{pmatrix} u_1 \\ u_2 \end{pmatrix}$$

$$\begin{pmatrix} y_1 \\ y_2 \end{pmatrix} = \underbrace{\begin{pmatrix} 1 & 1 & 0 \\ 0 & 0 & 1 \end{pmatrix}}_C \begin{pmatrix} x_1 \\ x_2 \\ x_3 \end{pmatrix}.$$

Now, let's make sure that this is indeed a state-space realization of the given system.

$$\begin{aligned}
C(sI - A)^{-1}B &= \begin{pmatrix} 1 & 1 & 0 \\ 0 & 0 & 1 \end{pmatrix} \begin{pmatrix} s-1 & 0 & 0 \\ -1 & s-1 & 0 \\ 6 & 0 & s+3 \end{pmatrix}^{-1} \begin{pmatrix} 1 & 0 \\ 0 & 1 \\ 0 & 1 \end{pmatrix} \\
&= \begin{pmatrix} 1 & 1 & 0 \\ 0 & 0 & 1 \end{pmatrix} \begin{pmatrix} \frac{1}{s-1} & 0 & 0 \\ \frac{1}{(s-1)^2} & \frac{1}{s-1} & 0 \\ -\frac{6}{(s-1)(s+3)} & 0 & \frac{1}{s+3} \end{pmatrix} \begin{pmatrix} 1 & 0 \\ 0 & 1 \\ 0 & 1 \end{pmatrix} \\
&= \begin{pmatrix} \frac{s}{(s-1)^2} & \frac{1}{s-1} & 0 \\ -\frac{6}{(s-1)(s+3)} & 0 & \frac{1}{s+3} \end{pmatrix} \\
&= \begin{pmatrix} \frac{s}{(s-1)^2} & \frac{1}{s-1} \\ -\frac{6}{(s-1)(s+3)} & \frac{1}{s+3} \end{pmatrix} = H(s).
\end{aligned}$$

Now, it has to be checked whether the above realization is minimal by computing the ranks of the reachability and observability matrices,  $\mathcal{R}$  and  $\mathcal{O}$ :

$$\begin{aligned}
\mathcal{R} &= (A^2B \quad AB \quad B) \\
&= \left( \begin{array}{cc|cc|cc} 1 & 0 & 1 & 0 & 1 & 0 \\ 2 & 1 & 1 & 1 & 0 & 1 \\ -12 & 9 & -6 & -3 & 0 & 1 \end{array} \right) \\
\text{rank}(\mathcal{R}) &= 3 \\
\mathcal{O} &= \begin{pmatrix} C \\ CA \\ CA^2 \end{pmatrix} \\
&= \begin{pmatrix} 1 & 1 & 0 \\ 0 & 0 & 1 \\ - & - & - \\ 2 & 1 & 0 \\ -6 & 0 & -3 \\ - & - & - \\ 3 & 1 & 0 \\ -12 & 0 & 9 \end{pmatrix} \\
\text{rank}(\mathcal{O}) &= 3.
\end{aligned}$$

Since the above realization is reachable and observable, the state-space realization is indeed minimal.

b) Using  $A$  obtained above, the poles of this system can be computed as eigenvalues of  $A$ : 1 with multiplicity of 2, and  $-3$  with multiplicity of 1.

**Exercise 28.1** a) The original system

$$\begin{aligned}
\dot{x} &= Ax + Bu \\
y &= Cx
\end{aligned}$$

with output feedback and additive input  $r$  becomes:

$$\begin{aligned}\dot{x} &= (A + BFC)x + Br \\ y &= Cx\end{aligned}$$

b) Suppose the new system is unreachable. Then there exists a left eigenvector  $w$  of matrix  $A+BFC$  orthogonal to  $B$ , that is  $w'(A+BFC) = \lambda w'$  and  $w'B = 0$ . But, from the second equality it follows that  $w'(A+BFC) = w'A = \lambda w'$ , therefore there exists an eigenvector of matrix  $A$  which is orthogonal to all columns of  $B$ . This contradicts reachability of the original system. Therefore output feedback does not change reachability.

c) Analogously, suppose the new system is unobservable. Then there exists a right eigenvector of matrix  $A$  orthogonal to  $C$ , that is  $(A+BFC)v = \lambda v$  and  $Cv = 0$ . The latter implies that  $(A+BFC)v = Av = \lambda v$ , therefore we constructed a right eigenvector of matrix  $A$  such that  $Cv = 0$ , which contradicts the assumption of observability of the original system. Hence, output feedback does not change observability.

**Exercise 29.1** a) The system has the following state-space representation:

$$\begin{aligned}\begin{pmatrix} \dot{x}_1 \\ \dot{x}_2 \\ \dot{x}_3 \\ \dot{x}_4 \end{pmatrix} &= \begin{pmatrix} 0 & 0 & 1 & 0 \\ 0 & 0 & 0 & 1 \\ -k/m_1 & k/m_1 & 0 & 0 \\ k/m_2 & -k/m_2 & 0 & 0 \end{pmatrix} \begin{pmatrix} x_1 \\ x_2 \\ x_3 \\ x_4 \end{pmatrix} + \begin{pmatrix} 0 & 0 \\ 0 & 0 \\ 1/m_1 & 0 \\ 0 & 1/m_2 \end{pmatrix} \begin{pmatrix} u \\ w \end{pmatrix} \\ y &= (0 \ 1 \ 0 \ 0) \begin{pmatrix} x_1 \\ x_2 \\ x_3 \\ x_4 \end{pmatrix}\end{aligned}$$

so that with  $m_1 = m_2 = 1$  and  $k = 1$ , we have the following state-space representation of the system:

$$\begin{aligned}\left\{ \begin{aligned} \begin{pmatrix} \dot{x}_1 \\ \dot{x}_2 \\ \dot{x}_3 \\ \dot{x}_4 \end{pmatrix} &= \begin{pmatrix} 0 & 0 & 1 & 0 \\ 0 & 0 & 0 & 1 \\ -1 & 1 & 0 & 0 \\ 1 & -1 & 0 & 0 \end{pmatrix} \begin{pmatrix} x_1 \\ x_2 \\ x_3 \\ x_4 \end{pmatrix} + \begin{pmatrix} 0 & 0 \\ 0 & 0 \\ 1 & 0 \\ 0 & 1 \end{pmatrix} \begin{pmatrix} u \\ w \end{pmatrix} \\ y &= (0 \ 1 \ 0 \ 0) \begin{pmatrix} x_1 \\ x_2 \\ x_3 \\ x_4 \end{pmatrix} \end{aligned} \right. \\ \rightarrow \begin{cases} \dot{\underline{x}} &= A\underline{x} + B\underline{u} \\ y &= C\underline{x} \end{cases}\end{aligned}$$

The eigenvalues of the system are  $0, 0$ , and  $\pm\sqrt{2}$ .

In order to compute the zeros of the transfer functions from  $u$  to  $y$ ,  $H_{uy}$  and  $w$  to  $y$ ,  $H_{wy}$ , let  $B = (B_u \ B_w)$ , then,

$$H_{uy} = C(sI - A)^{-1}B_u = \frac{1}{s^2(s^2 + 2)}$$

$$H_{wy} = C(sI - A)^{-1}B_w = \frac{s^2 + 1}{s^2(s^2 + 2)}.$$

Thus, the zero of  $H_{uy}$  does not exist and the zeros of  $H_{wy}$  are  $\pm i$ .

b) It is assumed that the observer has the following form :

$$\dot{\hat{x}} = A\hat{x} + B_u u + L(y - \hat{y}).$$

Closed loop system diagram is given in the figure below:

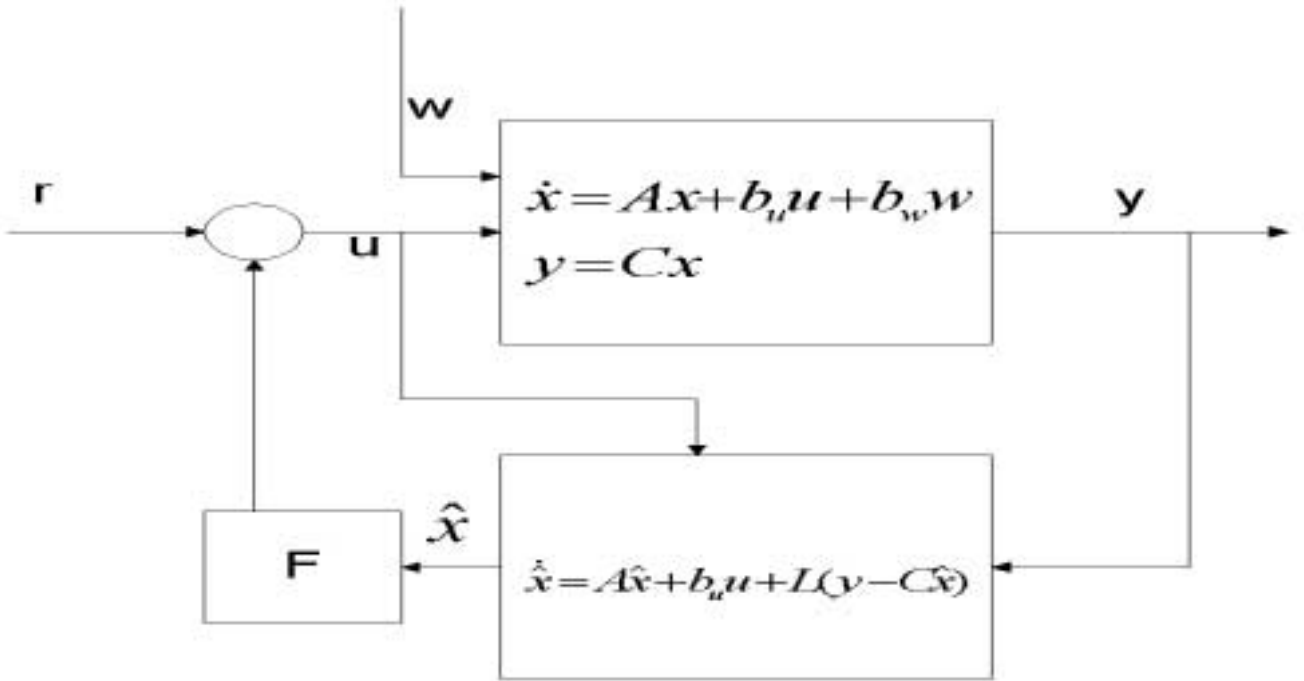

Figure 2: Block Diagram

The control employed is  $u = F\hat{x} + r$ , so that a state-space representation of the closed-loop system is

$$\begin{pmatrix} \dot{x} \\ \dot{\hat{x}} \end{pmatrix} = \begin{pmatrix} A + B_u F & -B_u F \\ 0 & A - LC \end{pmatrix} \begin{pmatrix} x \\ \tilde{x} \end{pmatrix} + \begin{pmatrix} B_u \\ 0 \end{pmatrix} r + \begin{pmatrix} B_w \\ 0 \end{pmatrix} w$$

$$y = (C \ 0) \begin{pmatrix} x \\ \tilde{x} \end{pmatrix},$$

or using  $\hat{x}$  we have

$$\begin{pmatrix} \dot{x} \\ \dot{\hat{x}} \end{pmatrix} = \begin{pmatrix} A & B_u F \\ LC & A + B_u F - LC \end{pmatrix} \begin{pmatrix} x \\ \hat{x} \end{pmatrix} + \begin{pmatrix} B_u \\ B_u \end{pmatrix} r + \begin{pmatrix} B_w \\ 0 \end{pmatrix} w$$

$$y = (C \ 0) \begin{pmatrix} x \\ \hat{x} \end{pmatrix}.$$

Also, it can be easily seen from the diagram that the state-space representation of the compensator is as follows:

$$\begin{aligned} \dot{\hat{x}} &= (A + B_u F - LC)\hat{x} + B_u r + Ly \\ u &= F\hat{x} + r. \end{aligned}$$

In the feedback control law  $u = F\hat{x} + r$ , only  $B_u$  is used so that it is to be used to check the reachability. Before designing the gain matrices,  $F$  and  $L$ , check the reachability and observability matrix ranks:

$$\begin{aligned} \mathcal{R} &= (B \ AB \ A^2B \ A^3B) \\ &= \begin{pmatrix} 0 & 1 & 0 & -1 \\ 0 & 0 & 0 & 1 \\ 1 & 0 & -1 & 0 \\ 0 & 0 & 1 & 0 \end{pmatrix} \\ \rightarrow \text{rank}(\mathcal{R}) &= 4. \\ \mathcal{O} &= \begin{pmatrix} C \\ CA \\ CA^2 \\ CA^3 \end{pmatrix} \\ &= \begin{pmatrix} 0 & 1 & 0 & 0 \\ 0 & 0 & 0 & 1 \\ 1 & -1 & 0 & 0 \\ 0 & 0 & 1 & -1 \end{pmatrix} \\ \rightarrow \text{rank}(\mathcal{O}) &= 4. \end{aligned}$$

Thus this system is reachable and observable.

Since  $B_u$  and  $C$  are one-column and one-row vectors respectively, Ackermann's formula can be used to place poles at desired locations.

First, compute the feedback matrix  $F$ . Since the desired pole locations for the transfer function from  $r$  to  $y$  are all at  $-1$ , the desired characteristic polynomial  $\alpha_F^d(\lambda)$  is

$$\alpha_F^d(\lambda) = (\lambda + 1)^4 = \lambda^4 + 4\lambda^3 + 6\lambda^2 + 4\lambda + 6,$$

so that

$$\begin{aligned} \alpha_F^d(A) &= A^4 + 4A^3 + 6A^2 + 4A + I \\ &= \begin{pmatrix} -3 & 4 & 0 & 4 \\ 4 & -3 & 4 & 0 \\ 4 & -4 & -3 & 4 \\ -4 & 4 & 4 & -3 \end{pmatrix}. \end{aligned}$$

Therefore using the Ackermann's formula  $F$  we have :

$$\begin{aligned}
 F &= -e_n^T(R)^{-1}\alpha_F^d(A) \\
 &= -(0 \ 0 \ 0 \ 1) \begin{pmatrix} 0 & 1 & 0 & -1 \\ 0 & 0 & 0 & 1 \\ 1 & 0 & -1 & 0 \\ 0 & 0 & 1 & 0 \end{pmatrix}^{-1} \begin{pmatrix} -3 & 4 & 0 & 4 \\ 4 & -3 & 4 & 0 \\ 4 & -4 & -3 & 4 \\ -4 & 4 & 4 & -3 \end{pmatrix} \\
 \therefore F &= (-4 \ 3 \ -4 \ 0).
 \end{aligned}$$

Similarly, the observer gain matrix  $L$  can be computed. Now, since the desired poles governing the observer error decay are all at  $-5$ , the desired characteristic polynomial  $\alpha_L^d(\lambda)$  is

$$\alpha_L^d(\lambda) = (\lambda + 5)^4 = \lambda^4 + 20\lambda^3 + 150\lambda^2 + 500\lambda + 625,$$

so that

$$\begin{aligned}
 \alpha_L^d(A) &= A^4 + 20A^3 + 150A^2 + 500A + 625I \\
 &= \begin{pmatrix} 477 & 148 & 480 & 20 \\ 148 & 477 & 20 & 480 \\ -460 & 460 & 477 & 148 \\ 460 & -460 & 148 & 477 \end{pmatrix}.
 \end{aligned}$$

Therefore using the Ackermann's formula for  $L$  we have :

$$\begin{aligned}
 L &= \alpha_L^d(A)\mathcal{O}^{-1}e_n \\
 &= \begin{pmatrix} 477 & 148 & 480 & 20 \\ 148 & 477 & 20 & 480 \\ -460 & 460 & 477 & 148 \\ 460 & -460 & 148 & 477 \end{pmatrix} \begin{pmatrix} 0 & 1 & 0 & 0 \\ 0 & 0 & 0 & 1 \\ 1 & -1 & 0 & 0 \\ 0 & 0 & 1 & -1 \end{pmatrix}^{-1} \begin{pmatrix} 0 \\ 0 \\ 0 \\ 1 \end{pmatrix} \\
 \therefore L &= \begin{pmatrix} 480 \\ 20 \\ 477 \\ 148 \end{pmatrix}.
 \end{aligned}$$

The poles of the compensator are

$$\begin{pmatrix} -3.0696 \pm 5.0771i \\ -8.9304 \pm 3.0654i \end{pmatrix}$$

and zeros are

$$\begin{pmatrix} 0.1471 \pm 0.9120i \\ -0.1944 \end{pmatrix}.$$

Its frequency response is shown in Figure 3.

c) Using the result obtained in b), the closed-loop transfer function from  $w$  to  $y$  can be determined as follows:

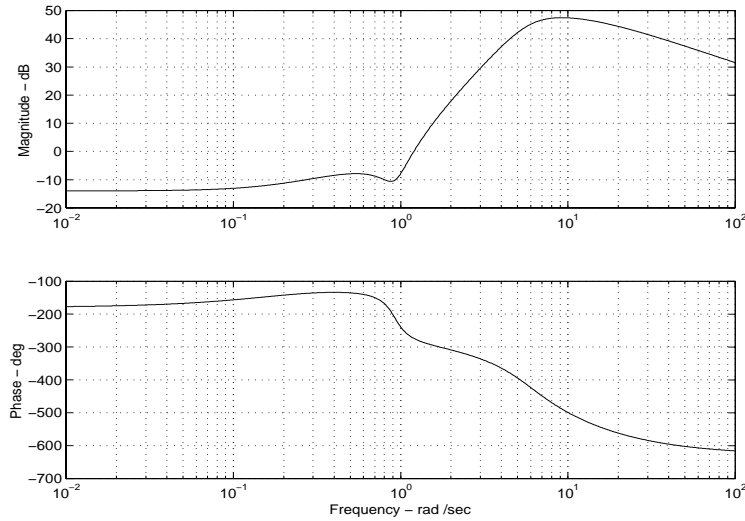

Figure 3: Frequency Response of Compensator

$$\begin{pmatrix} \dot{x} \\ \dot{\hat{x}} \end{pmatrix} = \begin{pmatrix} A & B_u F \\ LC & A + B_u F - LC \end{pmatrix} \begin{pmatrix} x \\ \hat{x} \end{pmatrix} + \begin{pmatrix} B_w \\ 0 \end{pmatrix} w$$

$$y = \begin{pmatrix} C & 0 \end{pmatrix} \begin{pmatrix} x \\ \hat{x} \end{pmatrix}.$$

Its Bode plot is shown in Figure 4. We can see that disturbance rejection at low frequencies is quite poor.

d) In order to obtain the simulation results, change the  $C$  matrix, then the closed-loop dynamics can now be described as follows:

$$\begin{pmatrix} \dot{x} \\ \dot{\hat{x}} \end{pmatrix} = \begin{pmatrix} A & B_u F \\ LC & A + B_u F - LC \end{pmatrix} \begin{pmatrix} x \\ \hat{x} \end{pmatrix} + \begin{pmatrix} B_u \\ B_u \end{pmatrix} r + \begin{pmatrix} B_w \\ 0 \end{pmatrix} w$$

$$y = \begin{pmatrix} x_1 \\ x_2 \\ u \end{pmatrix} + \begin{pmatrix} 0 \\ 0 \\ r \end{pmatrix} = \begin{pmatrix} 1 & 0 & 0 & 0 & 0 \\ 0 & 1 & 0 & 0 & 0 \\ & & 0 & & F \end{pmatrix} \begin{pmatrix} x \\ \hat{x} \end{pmatrix} + \begin{pmatrix} 0 \\ 0 \\ r \end{pmatrix}$$

In the simulation  $r$  and  $w$  are set to be zero. The simulation results are shown below:

Response to initial conditions decays to zero.

e) In the system developed in d), the initial conditions are set to be all zeros and the disturbance  $w(t)$  is a unit step at time  $t = 0$ . The simulation results are shown in Figure 6 We can see that step disturbance input leads to steady state errors, because the loop gain is low at DC. In general, pole-placement design does not care about control effort required to bring poles to desired locations, and may produce very large gains. Other design methods, like linear quadratic regulator, penalize high gains, and result in more practical controllers. One other thing to note is that it is usually a good idea to have faster estimation error dynamics than the closed loop plant dynamics, like was done in this design.

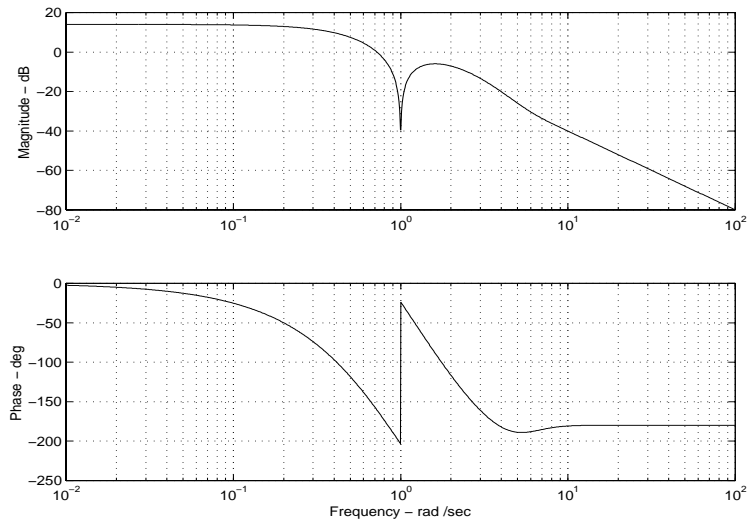

Figure 4: Bode Plot for  $T_{wy}$

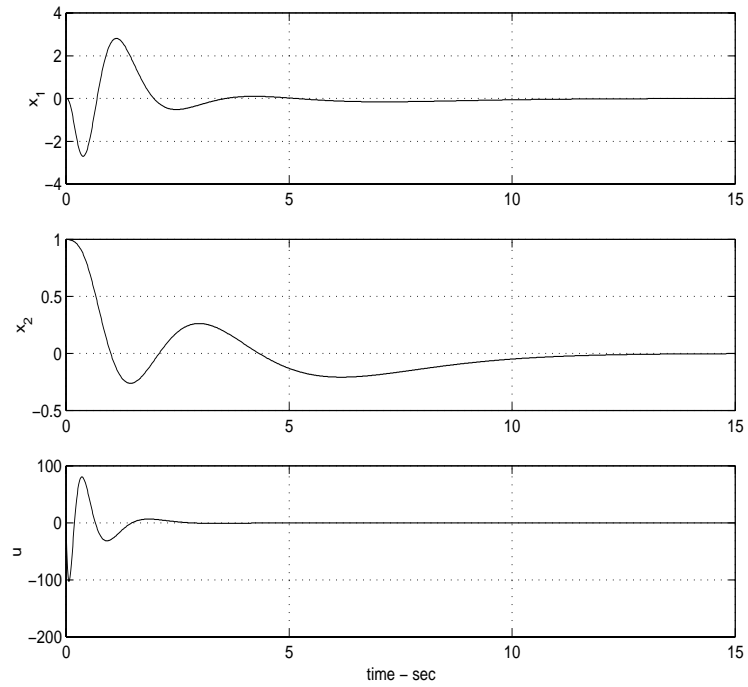

Figure 5: Transient Response of  $x_1$ ,  $x_2$ , and  $u$

Exercise 29.2 a) Given :

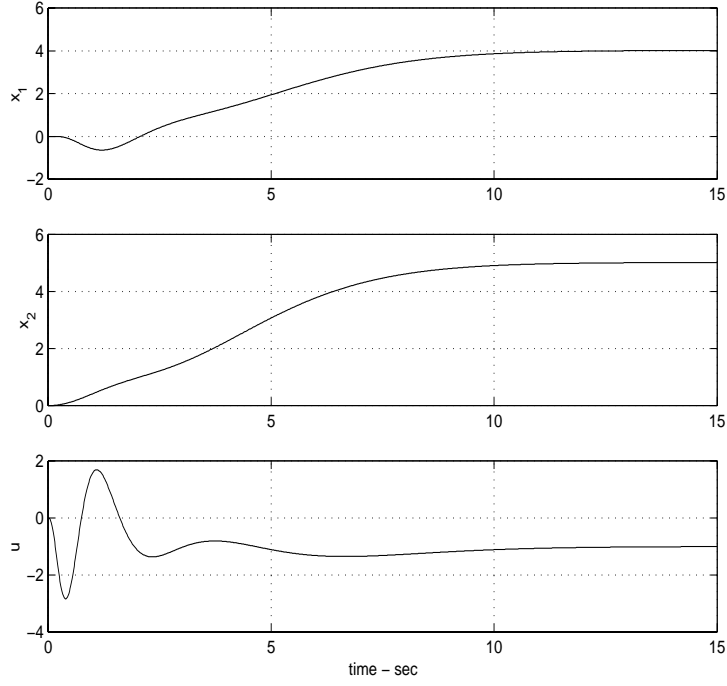

Figure 6: Step Response of  $x_1$ ,  $x_2$ , and  $u$

$$\begin{pmatrix} \dot{x}_1 \\ \dot{x}_2 \end{pmatrix} = \begin{pmatrix} A_{11} & A_{12} \\ A_{21} & A_{22} \end{pmatrix} \begin{pmatrix} x_1 \\ x_2 \end{pmatrix} + \begin{pmatrix} B_1 \\ B_2 \end{pmatrix} u$$

$$y = \begin{pmatrix} 0 & I \end{pmatrix} \begin{pmatrix} x_1 \\ x_2 \end{pmatrix} = C\underline{x},$$

where  $x_1 \in \mathbb{R}^r$  and  $x_2 \in \mathbb{R}^p$ . Here let  $z = x_1 - Lx_2$ , then its dynamics can be expressed in terms of  $z$ ,  $y$ , and  $u$  as follows:

$$\begin{aligned} \dot{z} &= \dot{x}_1 - L\dot{x}_2 \\ &= (A_{11}x_1 + A_{12}x_2 + B_1u) - L(A_{21}x_1 + A_{22}x_2 + B_2u) \\ &= (A_{11} - LA_{21})x_1 + (A_{12} - LA_{22})x_2 + (B_1 - LB_2)u \\ &= (A_{11} - LA_{21})(z + Lx_2) + (A_{12} - LA_{22})x_2 + (B_1 - LB_2)u \\ \rightarrow \dot{z} &= (A_{11} - LA_{21})z + ((A_{11} - LA_{21})L + (A_{12} - LA_{22}))y + (B_1 - LB_2)u. \end{aligned}$$

b) We have to show that the pair  $(A_{11}, A_{21})$  is observable iff the original system is observable.  
 $(\Leftarrow)$  Suppose the pair  $(A_{11}, A_{21})$  is not observable. Then  $A_{21}v = 0$  for some right eigenvector of  $A_{11}$ , associated with an eigenvalue of  $\lambda$ . Thus

$$\begin{pmatrix} A_{11} & A_{12} \\ A_{21} & A_{22} \end{pmatrix} \begin{pmatrix} v \\ 0 \end{pmatrix} = \lambda \begin{pmatrix} v \\ 0 \end{pmatrix}.$$

Also it is obvious that

$$\begin{pmatrix} 0 & I \end{pmatrix} \begin{pmatrix} v \\ 0 \end{pmatrix} = C \begin{pmatrix} v \\ 0 \end{pmatrix}.$$

Therefore there exists a nonzero vector  $(v \ 0)^T$  such that

$$\begin{pmatrix} A_{11} & A_{12} \\ A_{21} & A_{22} \end{pmatrix} \begin{pmatrix} v \\ 0 \end{pmatrix} = \lambda \begin{pmatrix} v \\ 0 \end{pmatrix}, \quad C \begin{pmatrix} v \\ 0 \end{pmatrix} = \begin{pmatrix} 0 & I \end{pmatrix} \begin{pmatrix} v \\ 0 \end{pmatrix} = 0,$$

which implies that the original system is unobservable.

( $\Rightarrow$ ) Suppose the original system is not observable. Then  $Cv_A = 0$  for some right eigenvector of  $A$ , associated with an eigenvalue  $\lambda_A$ , where  $v_A = \begin{pmatrix} v_1 \\ v_2 \end{pmatrix}$ , which implies that  $v_2 = 0$  since  $C = \begin{pmatrix} 0 & I \end{pmatrix}$ . So,

$$\begin{aligned} \begin{pmatrix} A_{11} & A_{12} \\ A_{21} & A_{22} \end{pmatrix} \begin{pmatrix} v_1 \\ v_2 \end{pmatrix} &= \lambda \begin{pmatrix} v_1 \\ v_2 \end{pmatrix} \\ \begin{pmatrix} A_{11} \\ A_{21} \end{pmatrix} v_1 &= \lambda \begin{pmatrix} v_1 \\ 0 \end{pmatrix} \\ \therefore A_{11}v_1 &= \lambda v_1 \\ A_{21}v_1 &= 0, \end{aligned}$$

thus the pair  $(A_{11}, A_{21})$  is not observable. This completes the proof.

c) Consider an observer for  $z$  in the following form:

$$\dot{\hat{z}} = (A_{11} - LA_{21})\hat{z} + ((A_{11} - LA_{21})L + (A_{12} - LA_{22}))y + (B_1 - LB_2)u,$$

which is essentially the expression obtained in a). With this observer, the error dynamics can be written as

$$\dot{\tilde{z}} = \dot{z} - \dot{\hat{z}} = (A_{11} - LA_{21})\tilde{z},$$

which is asymptotically stable, provided that the original system is observable as shown in b) by a proper choice of  $L$ .

d) Now we have the following control law:

$$u = F\hat{x} = F_1\hat{x}_1 + F_2x_2.$$

With this control law, we have the the following augmented systems:

$$\begin{aligned}
\text{Plant} & : \begin{cases} \begin{pmatrix} \dot{x}_1 \\ \dot{x}_2 \end{pmatrix} = \begin{pmatrix} A_{11} & A_{12} \\ A_{21} & A_{22} \end{pmatrix} \begin{pmatrix} x_1 \\ x_2 \end{pmatrix} + \begin{pmatrix} B_1 \\ B_2 \end{pmatrix} u \\ y & = \begin{pmatrix} 0 & I \end{pmatrix} \begin{pmatrix} x_1 \\ x_2 \end{pmatrix} \end{cases} \\
\text{Control law} & : u = F_1 \hat{x}_1 + F_2 x_2 \\
\text{Observer} & : \begin{cases} \dot{\hat{x}}_1 = \hat{z} + Lx_2 \\ \dot{\hat{z}} = (A_{11} - LA_{21})\hat{z} \end{cases}
\end{aligned}$$

Here, since  $\hat{x}_1 = x_1 - \tilde{z}$ , the augmented system needs three states, namely  $x_1$ ,  $x_2$ , and  $\tilde{z}$  as follows:

$$\begin{aligned}
\begin{pmatrix} \dot{x}_1 \\ \dot{x}_2 \end{pmatrix} & = \begin{pmatrix} A_{11} & A_{12} \\ A_{21} & A_{22} \end{pmatrix} \begin{pmatrix} x_1 \\ x_2 \end{pmatrix} + \begin{pmatrix} B_1 \\ B_2 \end{pmatrix} (F_1 \hat{x}_1 + F_2 x_2) \\
\rightarrow \begin{pmatrix} \dot{x}_1 \\ \dot{x}_2 \end{pmatrix} & = \begin{pmatrix} A_{11} & A_{12} \\ A_{21} & A_{22} \end{pmatrix} \begin{pmatrix} x_1 \\ x_2 \end{pmatrix} + \begin{pmatrix} B_1 \\ B_2 \end{pmatrix} (F_1(x_1 - \tilde{z}) + F_2 x_2) \\
\rightarrow \begin{pmatrix} \dot{x}_1 \\ \dot{x}_2 \end{pmatrix} & = \begin{pmatrix} A_{11} + B_1 F_1 & A_{12} + B_1 F_2 \\ A_{21} + B_2 F_1 & A_{22} + B_2 F_2 \end{pmatrix} \begin{pmatrix} x_1 \\ x_2 \end{pmatrix} - \begin{pmatrix} B_1 F_1 \\ B_2 F_1 \end{pmatrix} \tilde{z} \\
\therefore \begin{pmatrix} \dot{x}_1 \\ \dot{x}_2 \\ \dot{\tilde{z}} \end{pmatrix} & = \begin{pmatrix} A_{11} + B_1 F_1 & A_{12} + B_1 F_2 & -B_1 F_1 \\ A_{21} + B_2 F_1 & A_{22} + B_2 F_2 & -B_2 F_1 \\ 0 & 0 & A_{11} - LA_{21} \end{pmatrix} \begin{pmatrix} x_1 \\ x_2 \\ \tilde{z} \end{pmatrix},
\end{aligned}$$

where the last step comes from the dynamics of  $\tilde{z}$  described earlier. Therefore the closed loop poles lie in the set  $\sigma(A + BF) \cup \sigma(A_{11} - LA_{21})$ .

**Exercise 29.5** (a) Note that

$$\begin{aligned}
y_1 & = \frac{1}{s-1}(u_1 + u_2) \\
y_2 & = \frac{1}{s-1}(u_1 + u_2) + \frac{1}{s}u_1.
\end{aligned}$$

So, the second order minimal realization for  $P(s)$  has  $A = \begin{bmatrix} 1 & 0 \\ 0 & 0 \end{bmatrix}$ ,  $B = \begin{bmatrix} 1 & 1 \\ 1 & 0 \end{bmatrix}$ , and  $C = \begin{bmatrix} 1 & 0 \\ 1 & 1 \end{bmatrix}$ . You can verify that  $P(s) = C(sI - A)^{-1}B$ , and that  $(A, B, C)$  is both observable and reachable.

Now, we design  $F$  and  $L$  such that  $\text{eig}(A + BF) = \{-1, -1\}$  and  $\text{eig}(A + LC) = \text{eig}(A' + C'L') = \{-3, -3\}$  respectively. We could have chosen any LHP poles for the observer; it is generally a good idea to make the dynamics of the observer faster than those of the state feedback controller. Of course, in practice, there are limits of how fast one can make those dynamics (i.e. how negative the poles are).

It turns out in this problem that since  $A$  has a diagonal structure and  $B$  and  $C$  are invertible, the design is particularly easy. We want  $A + BF = \begin{bmatrix} -1 & 0 \\ 0 & -1 \end{bmatrix}$  and  $A + LC = \begin{bmatrix} -3 & 0 \\ 0 & -3 \end{bmatrix}$ .

Solving for  $F$ , we have that  $F = B^{-1} \left( \begin{bmatrix} -1 & 0 \\ 0 & -1 \end{bmatrix} - A \right) = \begin{bmatrix} 0 & -1 \\ -2 & 1 \end{bmatrix}$ . Similar calculations give  $L = \begin{bmatrix} -4 & 0 \\ 3 & -3 \end{bmatrix}$ .

(b) Notice that if  $P_{11} = \frac{1+\epsilon}{s-1}$  and  $\epsilon \neq 0$ ,  $P(s)$  can no longer be realized by a second order state space description. Verify that the new minimal state space representation has  $A_n = \begin{bmatrix} 1 & 0 & 0 \\ 0 & 0 & 0 \\ 0 & 0 & 1 \end{bmatrix}$ ,

$B_n = \begin{bmatrix} 1 & 1 \\ 1 & 0 \\ 1 & 0 \end{bmatrix}$ , and  $C_n = \begin{bmatrix} 1 & 0 & \epsilon \\ 1 & 1 & 0 \end{bmatrix}$ . Thus, for any  $\epsilon \neq 0$  an unstable mode, that is both reachable and observable, is introduced. Since this unstable mode was not taken into account in the design of the controller (i.e. the controller does not do anything about it), the unstable mode will be present in the dynamics of the closed loop system. Verify this by writing down the closed loop dynamics using the controller designed in part (a) and the plant  $(A_n, B_n, C_n, 0)$ ; find the  $A$  matrix of the closed loop system and calculate its eigenvalues.