

**15.053**

**May 16, 2006**

## **Decision Analysis 2**

**Utility Theory  
The Value of Information**

## **Quote of the day**

**No sensible decision can be made any longer without taking into account not only the world as it is, but the world as it will be. . .**

**Isaac Asimov (1920 - 1992)**

**A wise man makes his own decisions, an ignorant man follows public opinion.**

**Chinese Proverb**

**It doesn't matter which side of the fence you get off on sometimes. What matters most is getting off. You cannot make progress without making decisions."**

**Jim Rohn**

## Lotteries and Utility

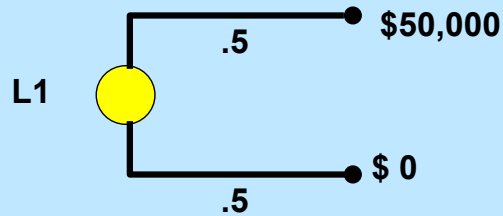

**Lottery 1:**  
a 50% chance at  
\$50,000 and a 50%  
chance of nothing.



**Lottery 2:** a sure  
bet of \$20,000

**How many prefer Lottery 1 to Lottery 2?**

**How many prefer Lottery 2 to Lottery 1?**

3

In terms of expected values, L1 is worth \$25,000 and L2 is worth \$20,000. When I ask students which they prefer, usually 19 out of 20 students state that they prefer L2. (I suspect that the remaining student would actually take L2 if given the choice in reality instead of hypothetically.) This reveals that we do not judge lotteries (or uncertain decisions) solely in terms of expected value.

The preference of L2 to L1 shows risk aversion. We are willing to sacrifice expected value in order to reduce the uncertainty. If one wants to use decision trees, this immediately brings up a quandary. If we evaluate each event node of a decision tree using the expected value criterion, can a person who is risk averse use a decision tree? The surprising answer is yes, as we shall soon see.

## Attitudes towards risk

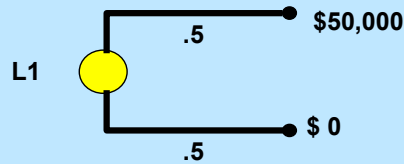

Lottery 1:  
a 50% chance at \$50,000 and a  
50% chance of nothing.



Lottery L2: a sure bet of \$ K

Suppose that Lottery 1 is worth a sure bet of \$K to you.

If  $K = \$25,000$ , then you are **risk neutral**.

If  $K < \$25,000$ , then you are **risk averse** or **risk avoiding**.

If  $K > \$25,000$ , then you are **risk preferring**.

4

A person who values lotteries according to their expected values is called “risk neutral.” Many people are risk neutral when the lotteries involve small amounts, but tend to be risk averse with larger amounts.

A person who is willing to sacrifice expected value in order to reduce the risk or uncertainty is called “risk averse” or “risk avoiding”. Most people when faced with lotteries such as L1 and L2 will be risk averse if the amounts of money involved are sufficiently large.

A person who is willing to sacrifice money in order to increase risk is called “risk preferring.” This is characteristic of someone who prefers uncertainty and risk.

Risk aversion and risk preference is actually quite a complex topic, and a person’s attitude towards risk depends a lot on the context for the lotteries. But we shall assume here that a person is risk averse.

## Overview of Utility Theory

- If a person is risk averse or risk preferring, it is still possible to use decision tree analysis.
- Step 1: develop a mathematical representation of a person's attitude towards risk: a utility curve.
- Step 2. Solve decision trees assuming that the person wants to maximize expected utility.
- Next: constructing a utility curve for some girl named Kaya.

5

Here we consider a girl named Kaya. We assume that Kaya can measure the utility of money by a curve called a utility curve  $f(\cdot)$ . For each dollar value, Kaya has a corresponding utility. For example, the utility of \$0 will be  $f(0)$ . The utility of \$50,000 will be  $f(50,000)$ .

We also assume that Kaya will make decisions by maximizing the expected utility. More on this later.

## Assumptions

- Kaya's utility is 1 for the best outcome.
  - That is  $f(50,000) = 1$
- Kaya's utility is 0 for the worst outcome.
  - That is  $f(0) = 0$ .
- Kaya lives on “utility island” where one can calculate utilities of lotteries by adding.

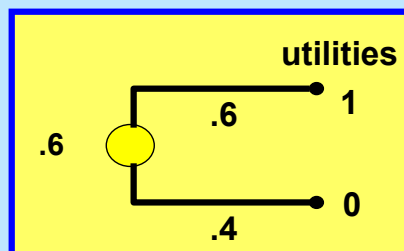

**Point to remember:  
Kaya uses expected  
utilities.**

6

We are considering problems in which the largest dollar value under consideration is \$50,000 and the smallest dollar value under consideration is \$0. So, we will create a utility function  $f(x)$  where  $x$  is between 0 and 50,000.

It is not obvious at this point, but it turns out that we can set  $f(0) = 0$ , and  $f(50,000) = 1$ . We will do so. In this way,  $0 \leq f(x) \leq 1$  for all  $x$  with  $0 \leq x \leq 50,000$ . We are assuming that utility is nondecreasing in dollar value, a typical assumption and a reasonable one. We measure utility in utils, and so we say that \$50,000 is worth one util.

The most important assumption on this slide is that Kaya evaluates lotteries using an expected utility criteria. If Kaya has a 60% chance of getting 1 util and a 40% chance of getting no utils. Kaya views this lottery as worth .6 utils.

At first glance, this assumption of working with expected utilities seems unreasonable. But it turns out to be a good approximation of risk aversion, and it is actually a valid model under certain reasonable axioms on attitudes towards risk. In any case, we will make the assumption of evaluating lotteries using expected utilities.

Note that \$50,000 is worth 1 util to Kaya and \$0 is worth no utils to Kaya. So a lottery with a 60% chance of winning \$50,000 and a 40% chance of winning nothing is worth .6 utils. At this point, we are not sure of the dollar value. But if value of this lottery to Kaya is  $d$ , it will follow that  $f(d) = .6$ .

## Additive utilities

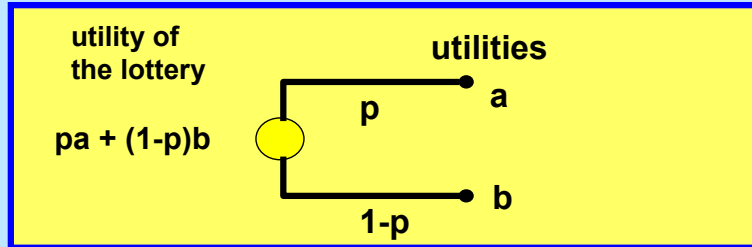

**In other words, the utility of a lottery can be computed using expected values.**

This slide emphasizes that lotteries can be evaluated in terms of expected utility.

## Converting dollars to utilities using a utility curve.

$$f(0) = 0 \text{ utils}$$

$$f(25,000) = .59 \text{ utils}$$

$$f(50,000) = 1 \text{ util}$$

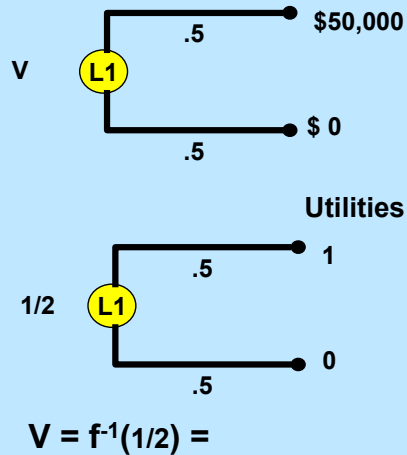
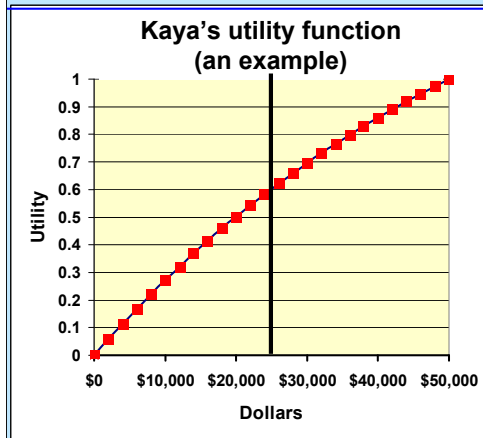

8

We will eventually create a utility curve for Kaya, and it may or may not look like the one on this page. But suppose for the moment that Kaya's utility curve is the one on this page. In this case, the lottery L1 is worth .5 since there is a 50% chance of getting one util and a 50% chance of getting no utils. When we look on the utility curve, it is a bit hard to read it exactly. But it appears that  $f(20,000) = .5$ . So, the Lottery L1 must also be worth \$20,000 to Kaya.

## Another Example

- Calculate the value of the following lottery. (Your answer will be approximate since it is hard to read the curve.)

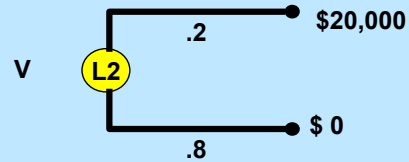
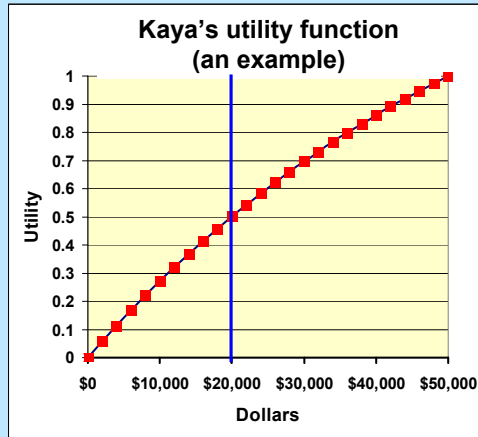

First convert to utilities. Then compute the expected utility. Then convert back.

~

9

The lottery L2 can be viewed as a 20% chance of getting .5 utils and an 80% chance of getting no utils. So, it is worth .1 utils. If one converts utils back to dollars, one sees that L2 is worth approximately \$4,000.

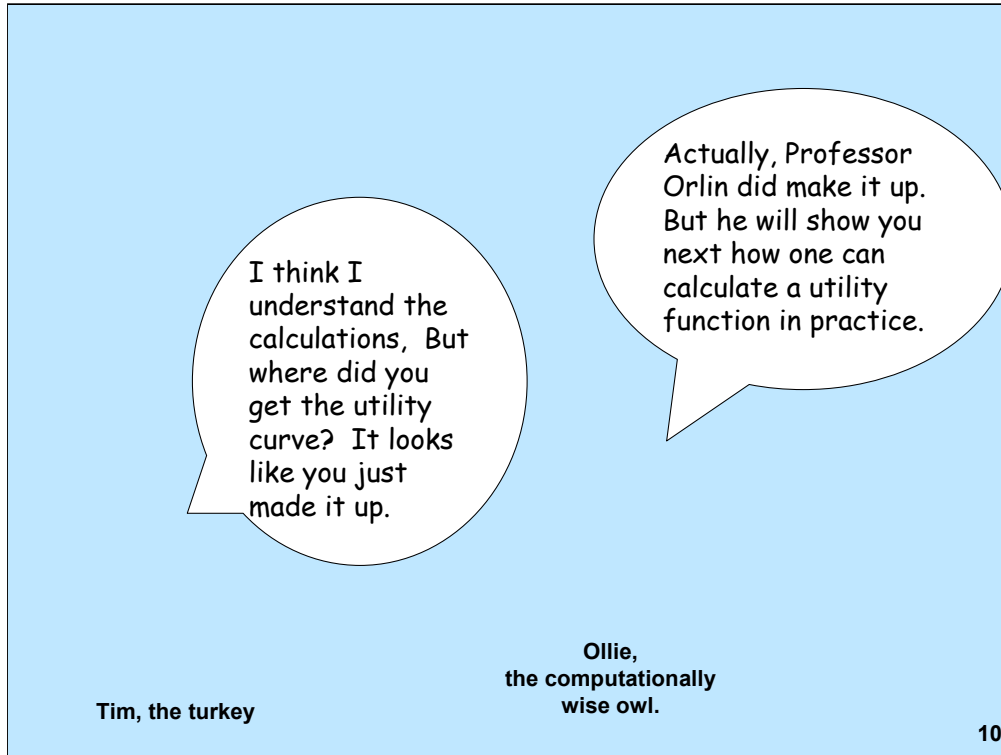

The utility curve was one of an infinite number of possible utility curves for a risk averse person. Once you have a utility curve, you can convert all dollars to utilities, and then you find the decisions that maximize expected utilities. At the end, you can convert all of the utilities back to dollars using the utility function.

## Building Utility Curves

As Dean Whitter may have said, we build utility curves the old fashioned way, one pixel at a time.



Professor  
James Orlin

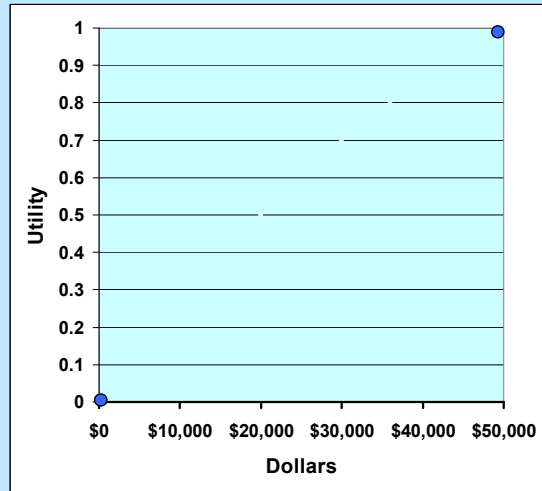

We can figure out the utility function for Kaya by asking one question at a time about preferences.

## What dollar amount has a utility of .5?

Kaya, what is the smallest amount that you would be willing to sell Lottery L1 for? That is, what is it worth to you?



Professor James Orlin

\$20,000 or a very valuable collectable doll.

Kaya

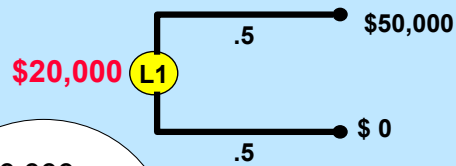

We next convert to utilities.

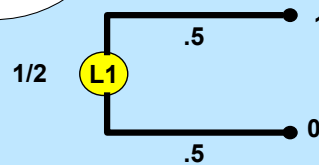

So,  $f(20,000) = 1/2$

We know that  $f(50,000) = 1$  and  $f(0) = 0$ . We know that lottery L1 has a utility of .5. So, we ask Kaya what it is worth in dollars. She says \$20,000. So we know that  $f(20,000) = .5$ .

## Adding a point to the utility curve

What question should we ask Kaya to determine which dollar amounts have utilities of .25 and .75?



Professor  
James Orlin

The certainty equivalent of the lottery L1 is \$20,000.

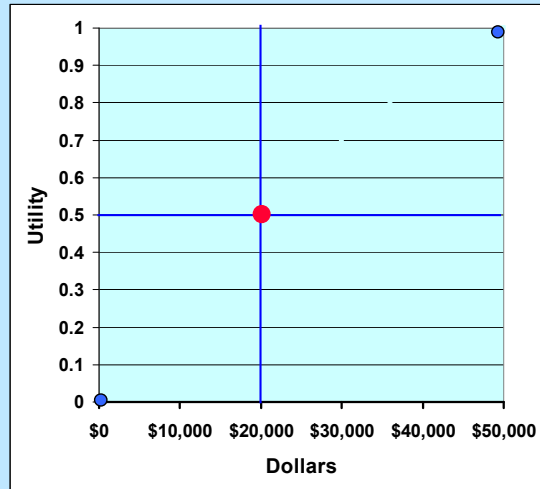

13

The certainty equivalent of a lottery is the dollar value of the lottery for the person. Kaya values L1 at \$20,000 and so we call \$20,000 the certainty equivalent (for Kaya) of L1.

The slide features a light blue background with a white border. On the left, a photograph of Professor James Orlin is shown. To his right, a speech bubble contains the text: "Kaya, what are lotteries L2 and L3 worth to you?". In the center, another speech bubble contains the text: "\$8,000 and \$32,000". To the right of the central text, there are two lotteries. Lottery L2 is a black branching line with a yellow circle labeled "L2" at the start. The top branch is labeled ".5" and ends at "\$20,000". The bottom branch is labeled ".5" and ends at "\$0". Below it, the text reads  $f(8,000) = 1/4$ . Lottery L3 is a blue branching line with a cyan circle labeled "L3" at the start. The top branch is labeled ".5" and ends at "\$50,000". The bottom branch is labeled ".5" and ends at "\$20,000". Below it, the text reads  $f(32,000) = 3/4$ . At the bottom right corner of the slide, the number "14" is displayed.

When we convert Lottery L2 to utils, it is worth  $1/4$  of a util. Kaya claims that her certainty equivalent for the lottery is \$8,000. So,  $f(8,000) = .25$ .

When we convert Lottery L3 to utils, it is worth .75 utils. Kaya claims that its certainty equivalent for her is \$32,000. So,  $f(32,000) = .75$ .

## Adding the two points to the curve

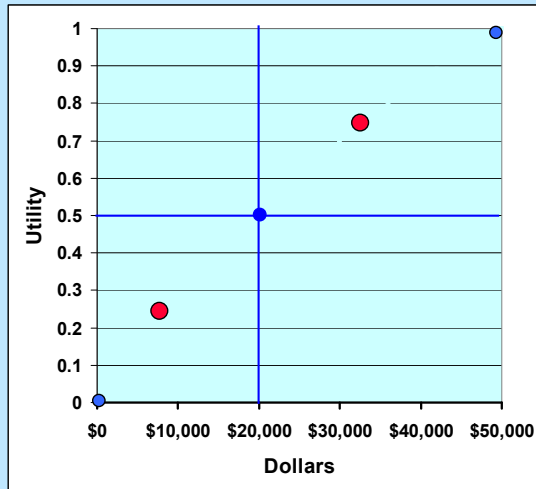

We fill in the next two points on the utility curve.

## Adding more points to the curve

- Next, we could ask Kaya what each of the following lotteries are worth in order to calculate  $u^{-1}(p)$  for  $p = 1/8, 3/8, 5/8, 7/8$

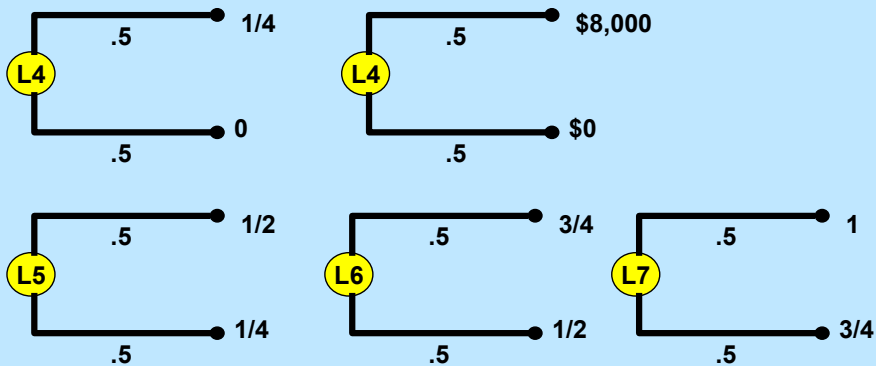

16

Hopefully, you see the pattern at this point. Lottery L4 is worth 1/8 of a util. If we ask Kaya the certainty equivalent of L4, we will fill in another point of  $f(\cdot)$ . For example, she may say it is worth \$3,200, at which point, we would conclude that  $f(3,200) = 1/8$ .

## Adding 4 more points to the curve

But adding one point at a time could take all day. Can you speed it up?

Tim, the turkey

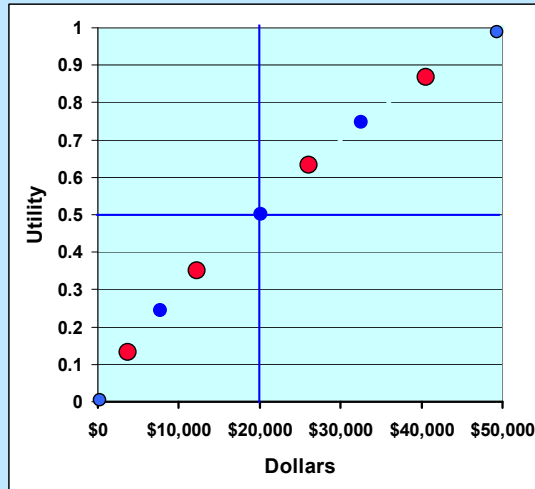

17

Creating a utility curve is somewhat of an art form in practice since most people have trouble being consistent on preferences, and it helps to smooth out the inconsistencies.

Here we adopt the alternative viewpoint. If you look at these 9 points, you can connect the dots and have a very good approximation of a utility curve.

Tim, for this example, we're ready to just approximate the rest of the curve.

Nooz, the most trusted name in fox.

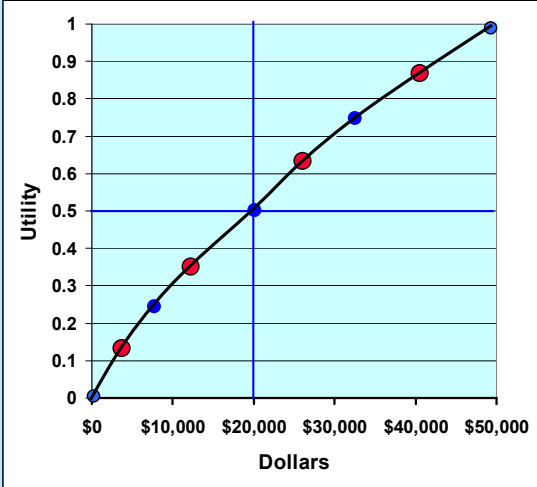

## On concavity of utility curves

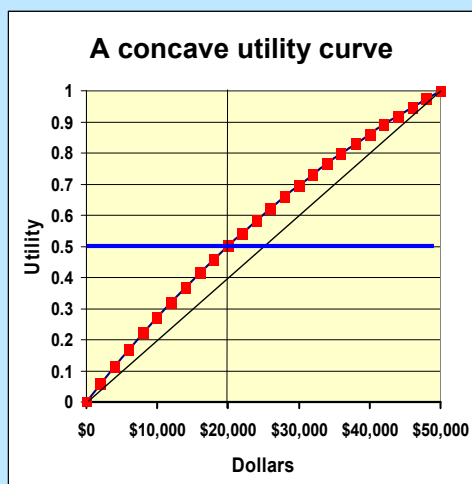

**Concave utility curves correspond to risk averse individuals.**

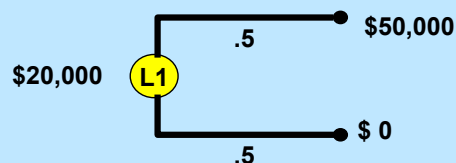

$f(20,000) = .5$  lies above the linear curve. On the linear curve, the value is  $2/5$ .

19

For risk averse individuals, utility curves look concave. That is, the line connecting two points on the curve lies below the curve.

The line connects  $(0, 0)$  with  $(50,000, 1)$ . The curve goes through the point  $(50,000q, q)$  for all  $q$  between 0 and 1.

To see that the curve is concave, consider the lottery in which one has a probability  $q$  of winning \$50,000 and a probability  $(1-q)$  of winning \$0. The utility of this lottery is  $q$  utils. If one is risk averse, then the certainty equivalent of this lottery (denoted CE) is some value  $CE < 50,000 \times q$ , the expected dollar value. In other words,  $f(CE) = q < f(50,000 \times q)$ . This latter inequality occurs because  $f$  is monotone increasing and  $CE < 50,000 \times q$ . So, the red curve is to the left of the line, which implies that the curve is concave.

## **On very fast computation of utility curves**

- **Although this approach can work well, it can be very time consuming to solicit the curve.**
- **And people are often inconsistent in their valuations of utilities.**
- **Next: an approach that requires only one data point.**

20

Asking the decision maker lots of questions is a tedious way of obtaining a utility curve.

## Exponential Utility Curves

- We can do even better if we assume that a utility function has a particular form. For example, suppose that we guess that Kaya's utility function is the following:

$$f(x) = (1 - e^{-x/R})/c. \quad \text{Note } f(0) = (1 - 1)/c = 0.$$

- R is called the risk tolerance.
- The higher R is, the **less** the person is tolerant of risk.
- The lower R, the **more** tolerant of risk
- c is chosen (depending on R) so that  $u(\$50,000) = 1$ .

Exponential  
Utility Curves

21

It turns out that an exponential utility curve is a pretty good approximation for lots of risk aversion. And the exponential utility curve has a very simple representation.  $f(x) = (1 - \exp(-x/R))/c$ . With this,  $f(x) = 0$ .

There is a unique choice of c and R so that  $f(50,000) = 1$  and  $f(25,000) = .6$ . In fact, we can set  $f(50,000)$  to be 1, and there will be unique choices for R and c if we specify  $f(x)$  for any one value of x between 0 and 50,000.

So, we can come up with a pretty good utility curve by just asking Kaya a single question: what is the certainty equivalent of a lottery that gives a 50% chance of returning \$50,000 and a 50% chance of returning nothing?

### An exponential utility function

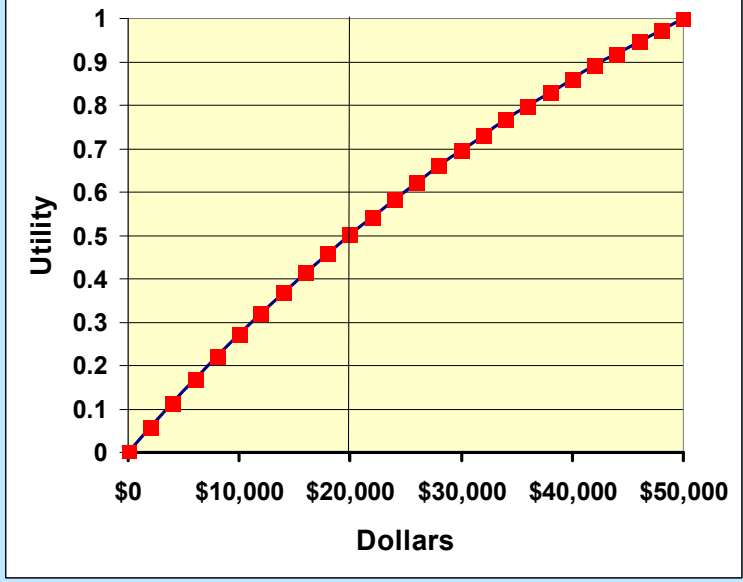

## How to use utility functions in decision trees

- **Step 1. Develop a utility function  $f(\cdot)$ .**
- **Step 2. Convert dollars to utils by replacing each outcome  $x$  by  $f(x)$ . (A util is our word for the basic unit of utility.)**
- **Step 3. Solve the decision tree using utils and using expected values**
- **Step 4. Convert utils back to dollars, by replacing each utility  $p$  by  $f^{-1}(p)$ .**

23

Develop a utility curve can be challenging. But once a utility curve is determined, it's easy to determine the value of a lottery by carrying out steps 2 to 4.

## **Mental Break**

**The 1991 Ig Nobel Prize in Education was awarded to Vice President Dan Quayle, who was the VP from 1989 to 1993.**

**“He left a legacy of lessons that are difficult to understand, and even harder to forget. His words sum up the man perhaps better than any description can.”**

**Here are some of Dan Quayle’s observations, as listed in the book, The Ig Nobel Prizes, by Marc Abrahams.**

**On a turn of a phrase.**

**What a waste it is to lose one's mind.**

**On his judgment.**

**I have made good judgments in the past.**

**I have made good judgments in the future.**

**On the place of the US in this world**

**We [the people of the US] have a firm commitment to NATO. We are a part of NATO. We have a firm commitment to Europe. We are a part of Europe.**

**On man's place in the universe**

**It's time for the human race to enter the solar system.**

**On bank failures.**

**Bank failures are caused by depositors who don't deposit enough money to cover losses due to mismanagement.**

**On pollution**

**It isn't pollution that is harming the environment. It's the impurities in the air and water that are doing it.**

**On success and failure**

**If we do not succeed, then we run the risk of failure.**

**Never surrender**

**My friends, no matter how rough the road may be, we can and we will never, never surrender to what is right.**

## A Decision Problem

- Jabba has a choice of two lotteries.

Lottery A

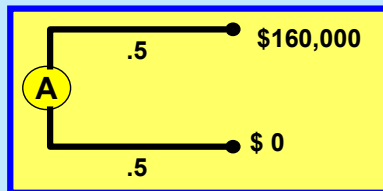

Lottery B

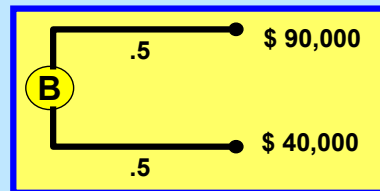

What is Jabba's best decision if  $f(\$K) = K^5$ ?

What is Jabba's best decision if  $f(\$K) = K$ ?

In this case, Jabba is risk neutral.

27

Admittedly Jabba is not a very common name. It was taken from Star Wars.

here we give a different utility function. There is nothing magic about having  $f(\text{largest value}) = 1$ . Here we have a utility function  $f(\cdot)$  that grows larger with  $K$ .

## Maximizing the Expected Value

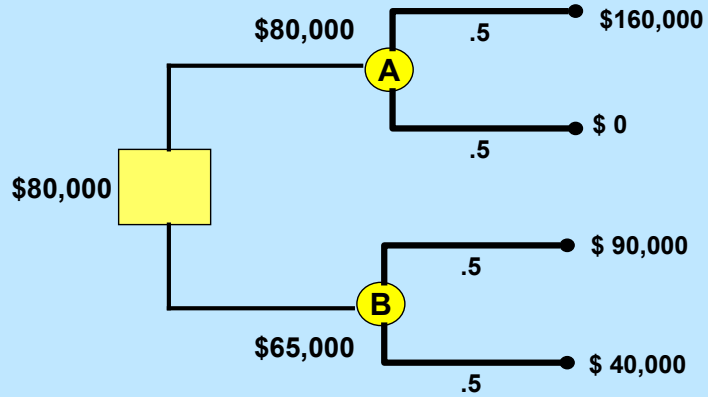

The expected value of Lottery A is \$80,000.

The expected value of Lottery B is \$65,000.

We illustrate how this utility function works on lotteries A and B. The expected values of A and B are \$80,000 and \$65,000 respectively. A risk neutral person will strongly prefer lottery A.

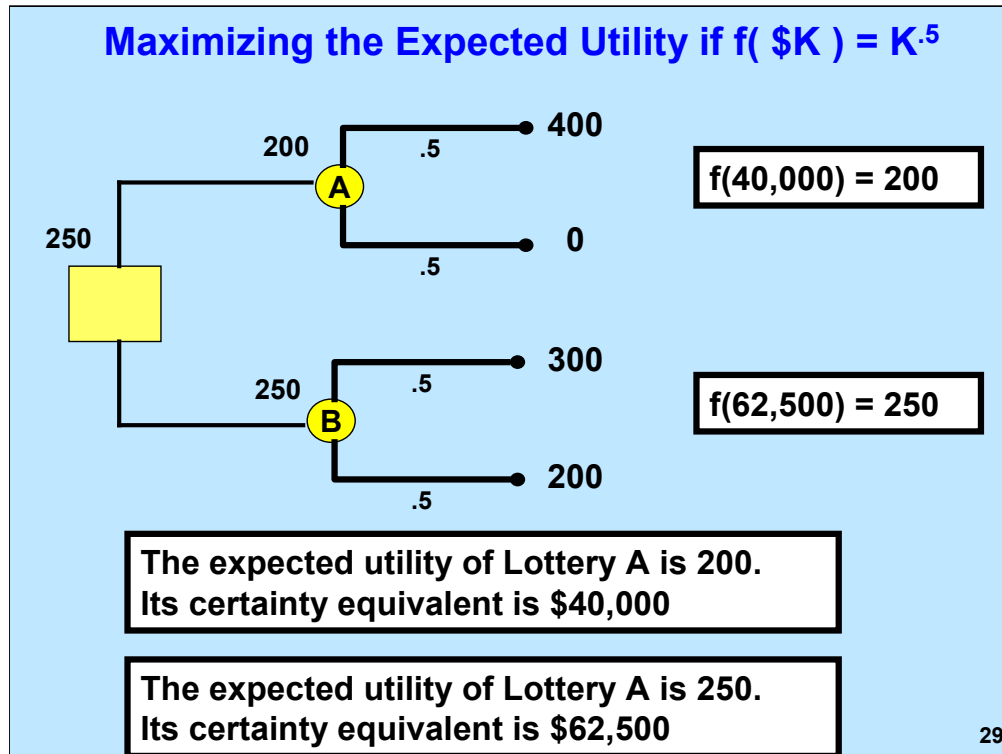

When we convert to utils, lottery A is worth 200 utils and lottery B is worth 250 utils. So, with this utility curve, the decision maker will strongly prefer lottery B to lottery A.

The certainty equivalent of lottery B is \$62,500 which is very close to its expected value of \$65,000. Even though there is a lot of uncertainty in lottery B, it is only modestly reflected in its value to the decision maker. The certainty equivalent of lottery B is only 4% less than its expected value.

The certainty equivalent of lottery A is \$40,000, which is half of its expected value. The uncertainty in lottery A is larger than that for lottery B, but it is still surprising (at least to me) that the uncertainty resulted in the certainty equivalent being only 50% of the expected value.

My personal take away lesson is that it can be hard to develop intuition on how certainty equivalents will compare to the expected values. One just needs to carry out the calculations and see what happens.

## Does utility theory really work?

- **Von Neumann and Morgenstern proved that utility theory is valid for a person if a certain set of very reasonable axioms are satisfied.**
- **In other words, it is probably never valid for a person, since people are inconsistent in their evaluations, which often depend on context.**
- **But, it's a reasonable approximation.**

30

Utility Theory was developed by Von Neumann and Morgenstern around 60 years ago. They based it on a plausible set of axioms.

In reality, it is at best an approximation to reality, if only because people are not consistent in their translation of dollars to utility. But it can often be a good approximation.

## Summary of Utility Theory

- **Attitudes towards risk can be incorporated into decision trees.**
- **Assessing a person's utility curve can be straightforward, and is sometimes very simple.**
- **Maximizing expected utility is a reasonable approximation to reality. It is correct when certain reasonable axioms are satisfied.**

31

Personally, I find it pretty amazing that it is useful to assume that a person is an expected utility optimizer. But it is useful.

## **Next: The value of Information.**

- **Using decision analysis to assess the value of collecting information.**

32

One of the wonderful things about decision trees is that it can map out a decision and help reveal whether a person needs new options.

Often the option that a person wants to consider is to obtain information about uncertain events. If you are making an important decision in the face of uncertainty, often learning more will help you to make a better decision.

## The value of information

- **Metzger Electronics has to decide between bringing one of two projects to market. The first product is a combination telephone and TV. The second product is an iPod clone. Either could be used for watching 15.053 podcasts.**



33

Here we consider a situation in which Metzger electronics is going to bring one of two products to market. Incidentally, this picture is the undergraduate picture of Mike Metzger.

## More on Metzger Electronic's products

- Mike asked Hamed and Professor Orlin what they thought about the products. Based on their responses, he believes the following.
- iPod clone : .4 chance of losing \$40 million  
.6 chance of gaining \$100 million
- Phone/TV : .5 chance of gaining \$50 million  
.5 chance of gaining \$60 million

34

Here is the data. As you can see, the success of the iPod clone is subject to great uncertainty. The Phone/TV is much more certain.

## Decision Tree (assume risk neutral)

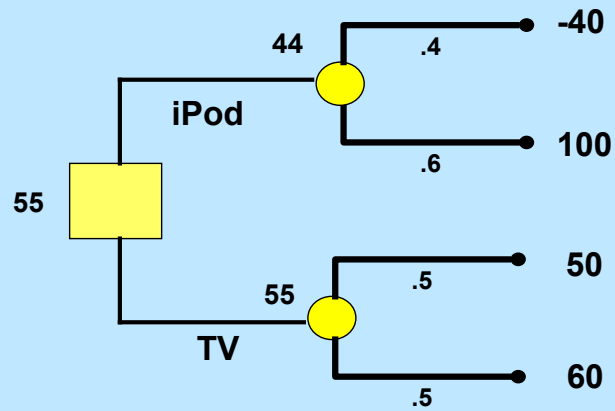

35

If we are risk neutral optimizers, we will clearly choose the TV. It's expected payoff is \$55 million. If we were risk averse, the preference for bringing the TV to market would be even stronger.

## More detail on the tree

- Metzger Electronics can hire Professor John Hauser in Marketing to find out whether the iPod clone will be successful. He will conduct a test market using tools developed with other OR faculty. Suppose that the test market will give perfect information on whether or not there will be a loss. How much is this information worth to Metzger Electronics?
- **EVWOI**: Expected value with original information. This is the value of the original tree, which is \$55 million.
- **EVWPI**: Expected value with perfect information. This is the value of the tree, assuming we can get perfect information (where the type of information is specified.)

36

But suppose that we could pay money to learn more about whether the iPod will be successful. If we were pretty sure that the iPod would be successful, then we would want to bring it to market. Otherwise, we would market the TV.

The value of information is the increase in the expected value for the decision if additional information is available. A very special case is when the information is 100% accurate. In this case, we refer to the value of perfect information. We will demonstrate this on the next slide.

So, the expected value of Metzger's decision with original information is  $EVWOI = \$55$  million.

## On perfect information and learning about the future.

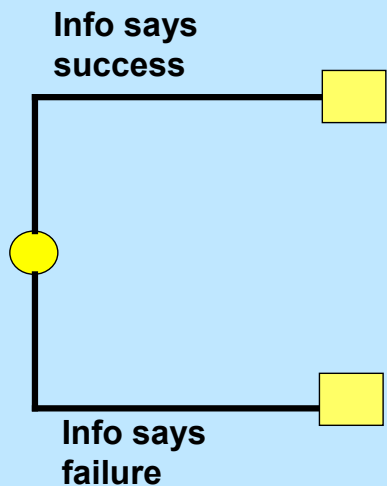

**Event node: Mike will find out whether the iPod clone will be successful or not.**

**What is the probability that he will find out that it will be successful?**

**View everything from Mike Metzger's perspective.**

37

We will soon compute the value of Metzger's decision if he receives perfect information about the success of the iPod. We refer to the Expected Value with Perfect Information or the EVWPI. When we compute this, it is always in reference to a specific type of information, which we specify. In this case, the information is whether the iPod will be marketed successfully.

So, the first event of the revised tree is an event node saying whether the iPod will be successful or not. We will now compute the probabilities associated with this event.

We look at this from Metzger's perspective. He will soon learn whether the iPod will be successful or not. (Given that the information is perfect, he really will learn whether it is successful or not. If the information were not perfect, he would not be 100% sure even after hearing the information.)

From Metzger's perspective, the probability that the "information will say success" is the same as the probability that the iPod will be successful, which is 60%. So, the probability associated with "INFO says success" is .6

## A question on probabilities

Why was the probability of a successful test .6?

Tim

The test is 100% accurate in this model. So the probability that the test will say the product is successful is the same as the probability it will be successful, which is .6.

Ollie

## On updated probabilities

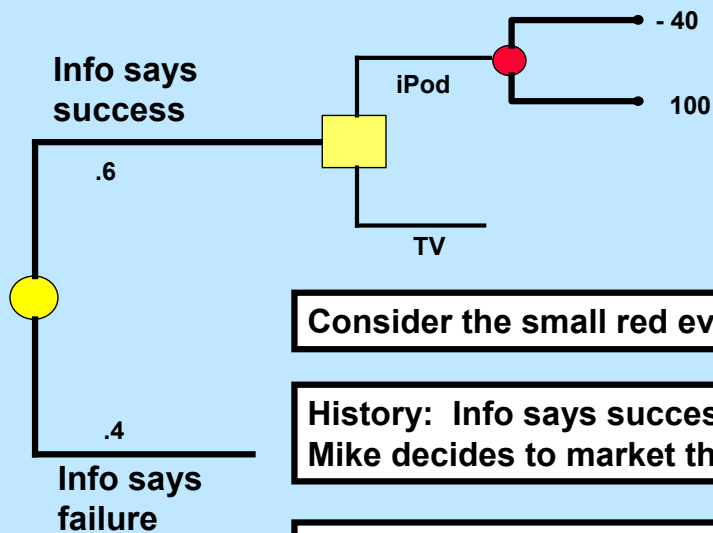

Consider the small red event node.

History: Info says success, and Mike decides to market the iPod.

What is the probability that the iPod will be successful?

39

Now consider the probability that the iPod will be successful. If you look at the red node in the tree, it has a history:

1. The information said that the iPod will be successful
2. Metzger chose to market the iPod

Given that the information has said that the iPod will be successful, there is a 100% chance that the iPod will be successful.

## A question on probabilities

Then why was the probability of the product being successful 1?

Tim

Actually, that was the probability of the iPod clone is successful given that Metzger has learned that the market test results were positive. Since the test results were infallible, it meant that there was a 100% chance of the product being successful.

Ollie

## Decision Tree (with perfect information)

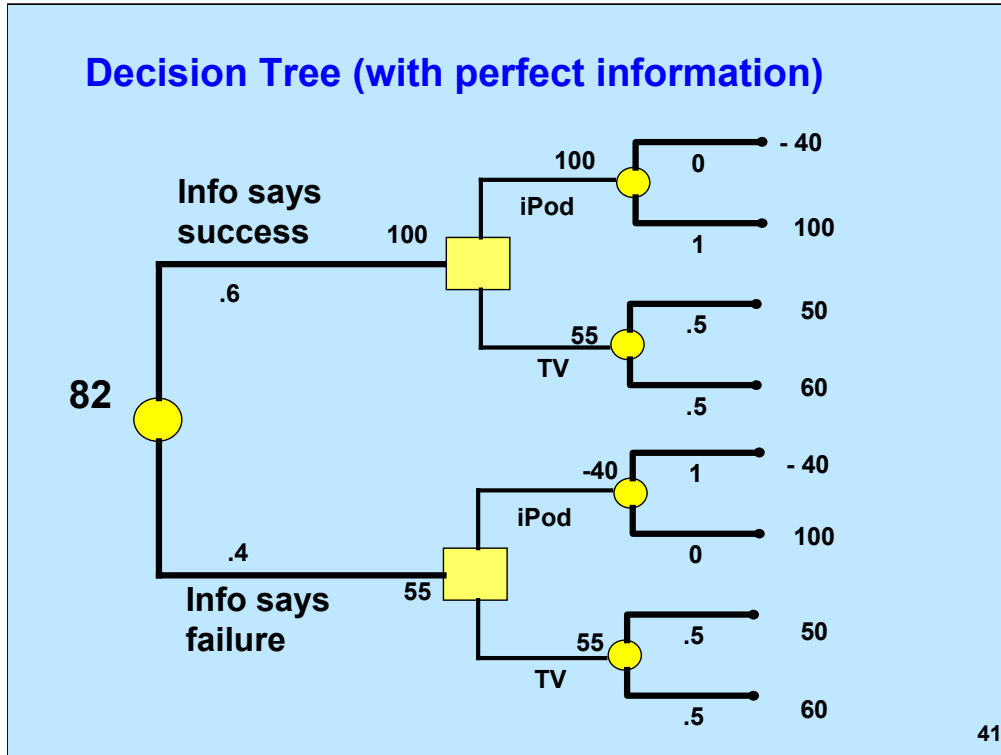

We now fill out the entire tree. The optimal expected value is \$82 million. If the information says the iPod will be successful, then Metzger markets the iPod and receives \$100 million. If the information says the iPod will not be successful, then Metzger Markets the TV/Phone for an expected return of \$55 million.

Thus the Expected Value with Perfect Information is \$82 million.

## Expected Value of Perfect Information

The Expected Value of Perfect Information: *EVPI*

$$\begin{aligned} \text{EVPI} &= \text{EWPI} - \text{EVWOI} \\ &= \$82 \text{ million} - \$55 \text{ million} \\ &= \$27 \text{ million} \end{aligned}$$

42

The Expected Value of Perfect Information is  $\text{EVWPI} - \text{EVWOI}$ , which is the net increase in expected value for having perfect information. In this case, it is worth \$27 million.

One can see why test markets can be so important to decision making.

## Expected Value of Perfect Information

**Next: let's compute the EVPI for the information on whether the TV will be very successful or not so successful.**

43

We leave this to the student to figure out. But you will find that the EVPI for whether the TV/Phone will be successful is \$0.

At first, a value of \$0 sounds absurd. After all, the information must be worth something. But it turns out that you will market the TV/Phone regardless of whether the expected return is \$50 million or \$60 million. Since the information does not affect the decision, it follows that  $EVWOI = EVWPI$  and so  $EVPI = \$0$ .

## The Expected Value of Imperfect Information

- **Decision trees can be used even if the information is imperfect. Suppose that Hauser has great test marketing but it is not 100% reliable.**

In general, one cannot expect information to be perfect. Even the best consultants make some mistakes. We will next compute the expected value of imperfect information. The only thing you can be absolutely sure of is that it won't be higher than the expected value of perfect information.

## Decision Tree (with some very good, but imperfect information)

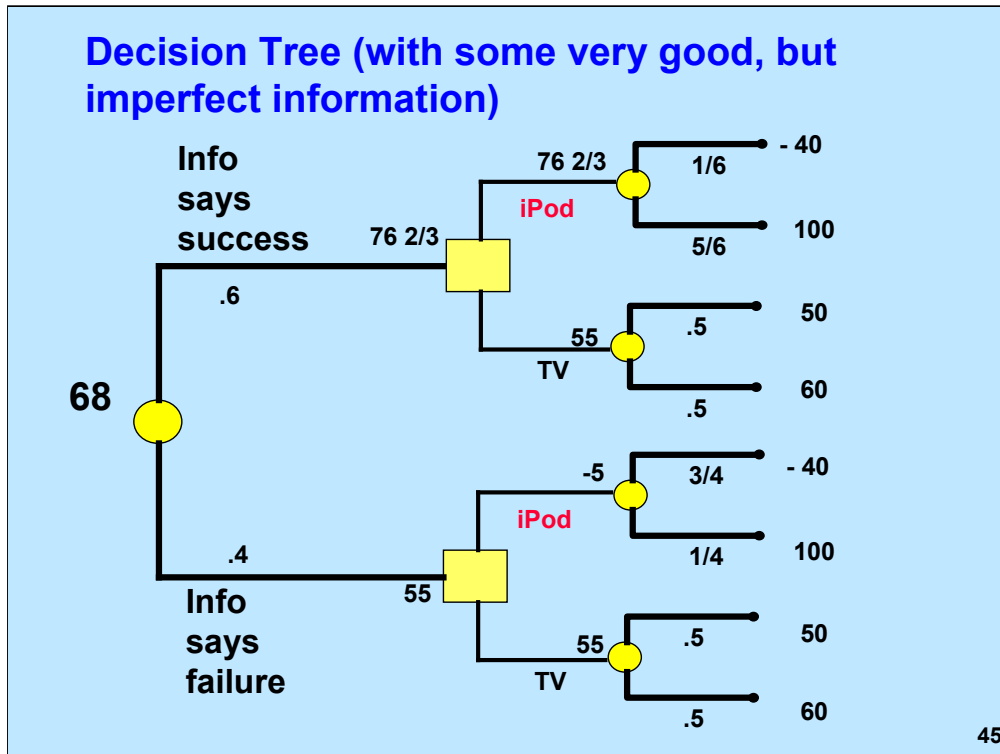

Here we assume that Hauser's firm is about 80% accurate in its predictions. There is a formal procedure to go through to compute the probabilities, but we skip it here. It's simple Bayesian analysis, but this is not the time to introduce lots of technical material into the lecture. Rather, we will make a few observations.

1. The info says success 60% of the time. It is a coincidence here that it is exactly the same as the probability that the iPod will be successful. But Metzger will expect that the info says success around the same proportion of the time that the iPod will be successful. Recall that all probabilities are from Metzger's perspective.
2. If the information says that the iPod will be successful, there is a 5/6 chance that it will be successful. Note that this is not 100%, but Metzger's confidence in the iPod's success has greatly increased over the original 60% because of the information.
3. If the information says the iPod will not be successful, Metzger's belief that it won't be successful goes to 75%.
4. As before, if the information says the iPod will be successful, the Metzger markets the iPod. This increases the expected value of the decision tree from its original \$55 million to \$68 million.

## The Expected Value of Imperfect Information

- **EVWII**: the expected value with imperfect information
- **EVII**: the expected value of imperfect information
- **EVII = EVWII – EVWOI**  
= \$68 MM - \$55 MM = \$13 MM.
- **Note: a relatively small error rate in the test costs more than \$14 million.**

46

So, the expected value with imperfect information is  $EVWII = \$68$  million.

The expected value of imperfect information is  $EVWII - EVWOI = \$13$  million.  
It's worth only about half as much as perfect information, but it's still worth a lot.

Where did all of those probabilities come from?

They relied on some information that we didn't include here, and are based on some calculations using Bayesian probability updates.

Given that this is the last technical lecture of the term, we decided not to give one more technical thing for students to learn.

Tim

Ollie

47

## Summary on the Value of Information

- The value of information is the increase in the value of the decision problem if new information is provided.
- EVPI is the value of perfect information.
- $EVPI = EVWPI - EVWOI$
- Decision trees often incorporate decisions about whether to gather information.

## **End of class**

- **That's all for formal lectures for this term.**
- **Next Class: the Excel Assignments, and using models in practice: a class discussion.**
- **Last class: games, some review, some surprises, and more.**