

2.171 Problem Set 2 Solutions

Out: Wednesday, September 20, 2006

Problem 1: FPW 4.5 a, b, c

(a)

$$u(k+2) = 0.25u(k)$$

$$u(k) = A_i z^k$$

$$u(k+2) = A_i z^{k+2}$$

$$A_i z^{k+2} = 0.25 A_i z^k$$

$$z^2 = 0.25$$

(b)

$$z = \pm 0.5$$

Since z is less than 1, the solution is stable.

(c)

$$u(k) = A_1 z_1^k + A_2 z_2^k$$

$$0 = A_1 + A_2$$

$$1 = A_1 z_1 + A_2 z_2$$

$$\begin{bmatrix} 1 & 1 \\ 0.5 & -0.5 \end{bmatrix} \begin{bmatrix} A_1 \\ A_2 \end{bmatrix} = \begin{bmatrix} 0 \\ 1 \end{bmatrix}$$

$$\begin{bmatrix} 1 & 1 \\ 0 & -1 \end{bmatrix} \begin{bmatrix} A_1 \\ A_2 \end{bmatrix} = \begin{bmatrix} 0 \\ 1 \end{bmatrix}$$

$$A_2 = -1, A_1 = 1$$

Problem 2: FPW 4.6

$$z^2 - 2r \cos(\theta)z + r^2 = 0$$

$$z = \frac{2r \cos(\theta) \pm \sqrt{4r^2 \cos^2(\theta) - 4r^2}}{2}$$

$$z = \frac{2r \cos(\theta) \pm 2r \sqrt{\cos^2(\theta) - 1}}{2}$$

$$z = \frac{2r \cos(\theta) \pm 2r \sin(\theta)}{2}$$

$$z = r \cos(\theta) \pm r \sin(\theta) = r e^{\pm j\theta}$$

Problem 3: FPW 4.9 a, b, c

(a)

$$G(s) = \frac{K}{s}$$

$$\frac{G(s)}{s} = \frac{K}{s^2}$$

$$\ell^{-1}\left\{\frac{G(s)}{s}\right\} = Kt = KkT$$

From Appendix B, we find:

$$Z\left\{\frac{G(s)}{s}\right\} = \frac{KTz}{(z-1)^2}$$

$$G(z) = \frac{z-1}{z} \frac{KTz}{(z-1)^2} = \frac{KT}{z-1}$$

(b)

$$G(s) = \frac{3}{s(s+3)}$$

$$\frac{G(s)}{s} = \frac{3}{s^2(s+3)}$$

$$\frac{G(s)}{s} = \frac{A}{s} + \frac{B}{s+3} + \frac{C}{s^2}$$

$$(A+B)s^2 + (3A+C)s + 3C = 3, C = 1, A = -\frac{1}{3}, B = \frac{1}{3}$$

$$\ell^{-1}\left\{\frac{G(s)}{s}\right\} = -\frac{1}{3}u(kT) + \frac{1}{3}e^{-3kT} + kT$$

From Appendix B, we find:

$$Z\left\{\frac{G(s)}{s}\right\} = -\frac{1}{3} \frac{z}{z-1} + \frac{1}{3} \frac{z}{z-e^{-3T}} + \frac{Tz}{(z-1)^2}$$

$$G(z) = \frac{z-1}{z} \left(-\frac{1}{3} \frac{z}{z-1} + \frac{1}{3} \frac{z}{z-e^{-3T}} + \frac{Tz}{(z-1)^2} \right) = -\frac{1}{3} + \frac{1}{3} \frac{z-1}{z-e^{-3T}} + \frac{T}{z-1}$$

(c)

$$G(s) = \frac{3}{(s+1)(s+3)}$$

$$\frac{G(s)}{s} = \frac{3}{s(s+1)(s+3)}$$

$$\frac{G(s)}{s} = \frac{A}{s} + \frac{B}{s+1} + \frac{C}{s+3}$$

$$A = 1, B = -\frac{3}{2}, C = \frac{1}{2}$$

$$\ell^{-1}\left\{\frac{G(s)}{s}\right\} = u(kT) - \frac{3}{2}e^{-kT} + \frac{1}{2}e^{-3kT}$$

From Appendix B, we find:

$$Z\left\{\frac{G(s)}{s}\right\} = \frac{z}{z-1} - \frac{3}{2}\frac{z}{z-e^{-T}} + \frac{1}{2}\frac{z}{z-e^{-3T}}$$

$$G(z) = \frac{z-1}{z} \left(\frac{z}{z-1} - \frac{3}{2}\frac{z}{z-e^{-T}} + \frac{1}{2}\frac{z}{z-e^{-3T}} \right) = 1 - \frac{3}{2}\frac{z-1}{z-e^{-T}} + \frac{1}{2}\frac{z-1}{z-e^{-3T}}$$

Problem 4: FPW 4.11

(a) See Figure 1.

$$\begin{bmatrix} \dot{x}_1 \\ \dot{x}_2 \end{bmatrix} = \begin{bmatrix} 0 & 1 \\ -3 & -4 \end{bmatrix} \begin{bmatrix} x_1 \\ x_2 \end{bmatrix} + \begin{bmatrix} \dot{x}_1 \\ \dot{x}_2 \end{bmatrix}$$

$$y = \begin{bmatrix} 1 & 0 \end{bmatrix} \begin{bmatrix} x_1 \\ x_2 \end{bmatrix}$$

$$\mathbf{F} = \begin{bmatrix} 0 & 1 \\ -3 & -4 \end{bmatrix}$$

$$\mathbf{G} = \begin{bmatrix} 0 \\ 1 \end{bmatrix}$$

$$\mathbf{H} = \begin{bmatrix} 3 & 0 \end{bmatrix}$$

$$J = 0$$

(b)

$$G(s) = \frac{3}{(s+1)(s+3)} = 3 \left(\frac{\frac{1}{2}}{s+1} - \frac{\frac{1}{2}}{s+3} \right)$$

$$\xi = \begin{bmatrix} \frac{\frac{1}{2}}{s+1} \\ -\frac{\frac{1}{2}}{s+3} \end{bmatrix}$$

$$\dot{\xi} = \mathbf{A}\xi + \mathbf{B}u$$

$$y = \mathbf{C}\xi + \mathbf{D}u$$

$$\mathbf{A} = \begin{bmatrix} -1 & 0 \\ 0 & -3 \end{bmatrix}$$

$$\mathbf{B} = \begin{bmatrix} \frac{1}{2} \\ \frac{1}{2} \end{bmatrix}$$

$$\mathbf{C} = \begin{bmatrix} 3 & -3 \end{bmatrix}$$

$$D = 0$$

(c)

$$\begin{aligned}\frac{X_2}{U} &= \frac{s}{s^2 + 4s + 3} = -\frac{\frac{1}{2}}{s + 1} + \frac{\frac{3}{2}}{s + 3} \\ \frac{X_1}{U} &= \frac{1}{s^2 + 4s + 3} = \frac{\frac{1}{2}}{s + 1} - \frac{\frac{1}{2}}{s + 3} \\ \mathbf{x} &= \begin{bmatrix} -1 & 1 \\ 3 & -1 \end{bmatrix} \xi\end{aligned}$$

(d)

$$\begin{aligned}\mathbf{A} &= \begin{bmatrix} 1.5 & 0.5 \\ 0.5 & 0.5 \end{bmatrix} \begin{bmatrix} 0 & 1 \\ -3 & -4 \end{bmatrix} \begin{bmatrix} -1 & 1 \\ 3 & -1 \end{bmatrix} = \begin{bmatrix} -3 & -4 \\ 0 & 1 \end{bmatrix} \\ \mathbf{B} &= \begin{bmatrix} 1.5 & 0.5 \\ 0.5 & 0.5 \end{bmatrix} \begin{bmatrix} 0 \\ 1 \end{bmatrix} = \begin{bmatrix} 0.5 \\ 0.5 \end{bmatrix} \\ \mathbf{C} &= \begin{bmatrix} 3 & 0 \end{bmatrix} \begin{bmatrix} -1 & 1 \\ 3 & -1 \end{bmatrix} = \begin{bmatrix} 3 & -3 \end{bmatrix} \\ D &= 0 = J\end{aligned}$$

Problem 5: FPW 4.12

(a) See Figure 2.

(b) See Figure 3.

(c) The step response begins at negative values for $\alpha > 1$.

Problem 6: FPW 4.15

See Figure 4.

Problem 7: FPW 4.16

(a)

$$H(z) = \frac{-1.396z + 0.9906}{z^2 - 1.42 + 0.81} + \frac{2.396z + 0.3885}{z^2 - 1.2z + 0.5}$$

See Figure 5.

(b) See Figure 6.

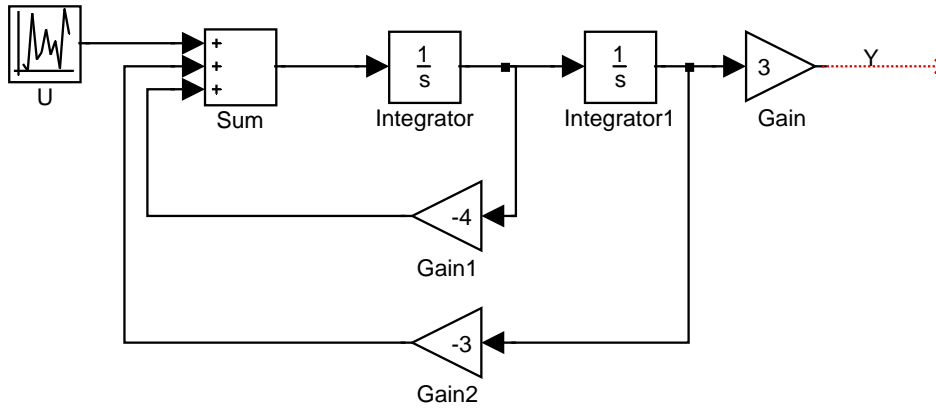

Figure 1: Problem 4.11

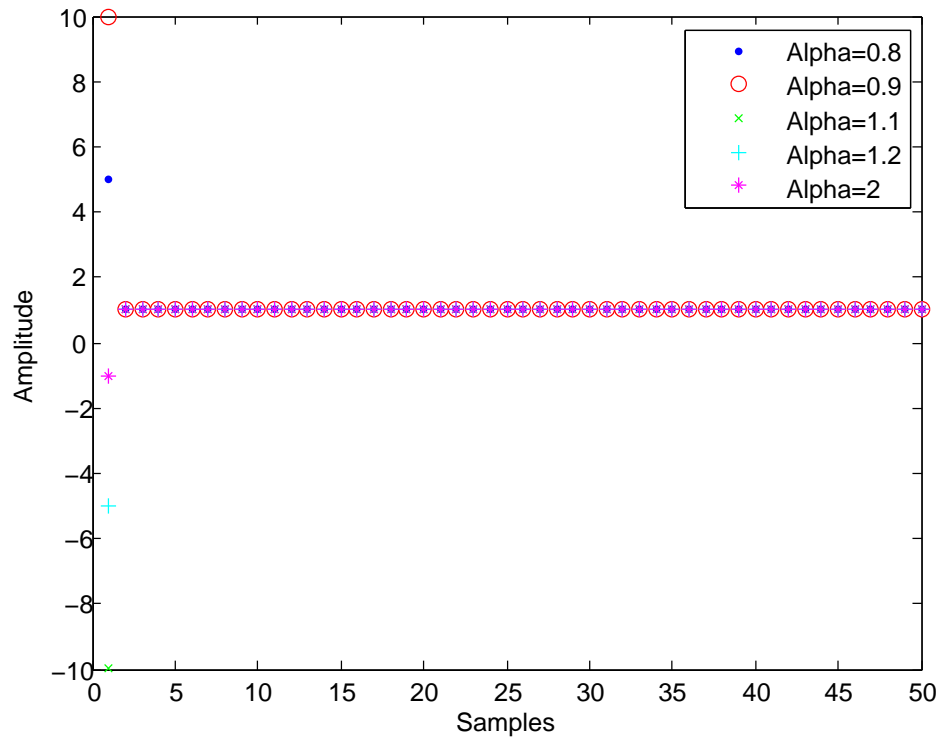

Figure 2: Problem 4.12(a)

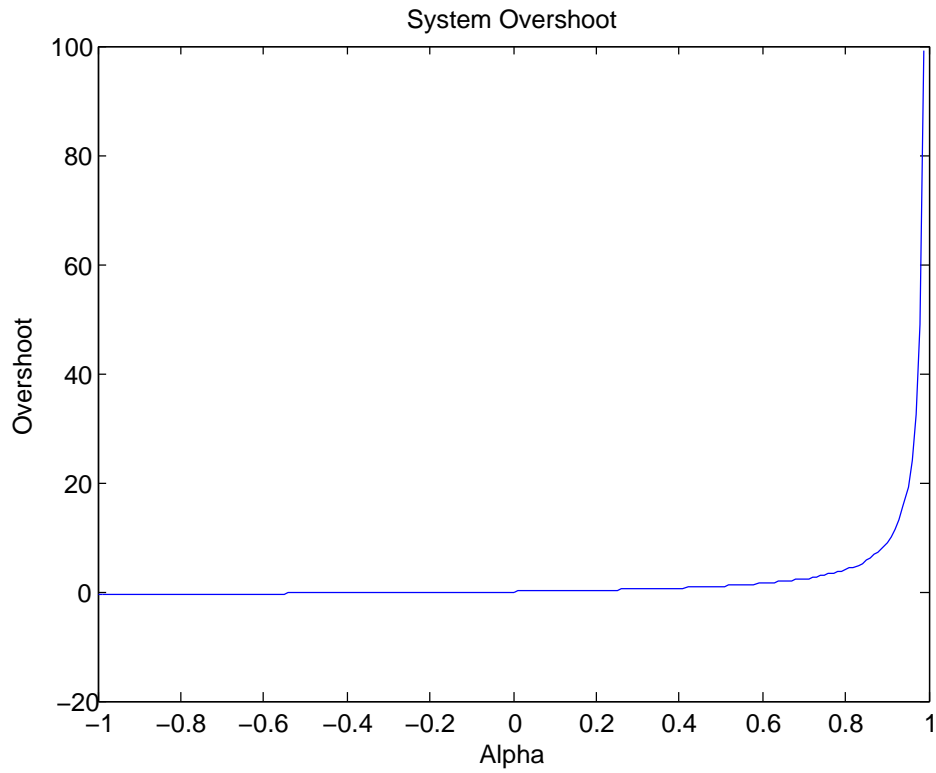

Figure 3: Problem 4.12(b)

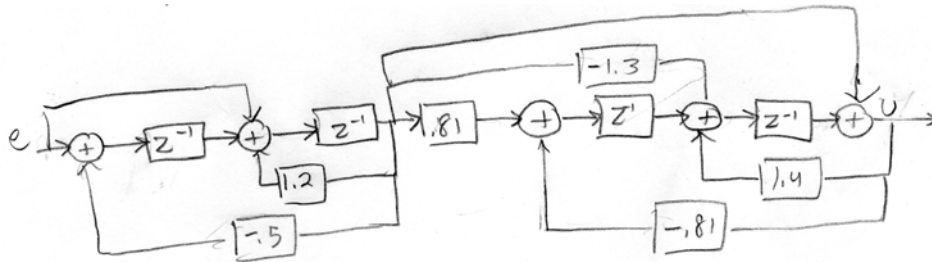

Figure 4: Problem 4.15

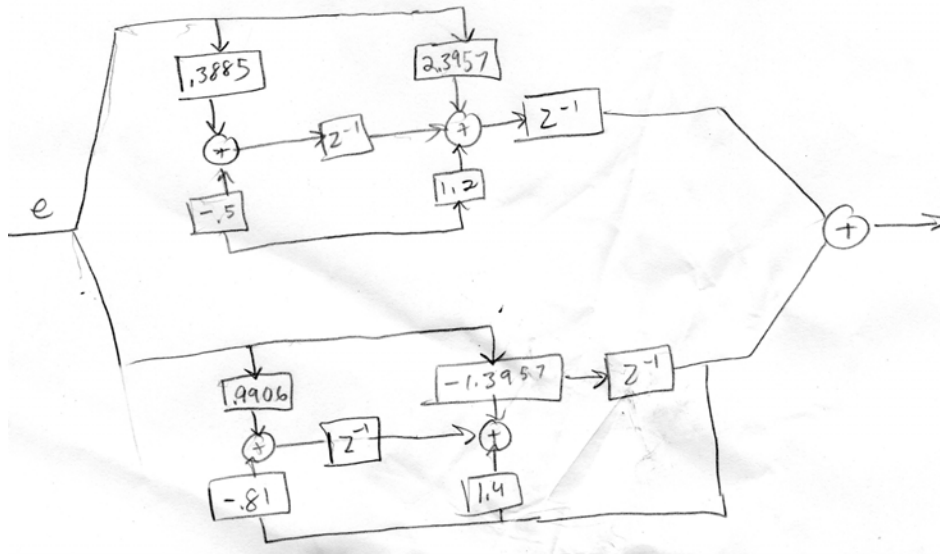

Figure 5: Problem 4.16(a)

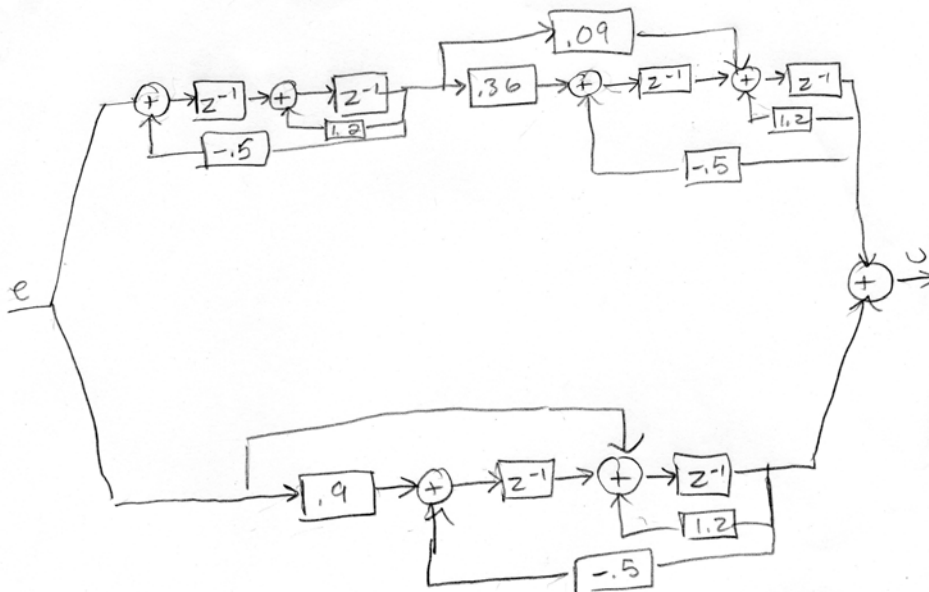

Figure 6: Problem 4.16(b)