

MIT OpenCourseWare
<http://ocw.mit.edu>

12.740 Paleoceanography
Spring 2008

For information about citing these materials or our Terms of Use, visit: <http://ocw.mit.edu/terms>.

Atmospheric CO₂ and Ocean Chemistry

12.740 Topic 11 Spring 2008

Recall: Ice core evidence for changes in atmospheric CO₂

- Pre-anthropogenic p_{CO₂} was about 280 ppmV
- Glacial p_{CO₂} was about 190 ppmV. Six Antarctic ice cores give same number.

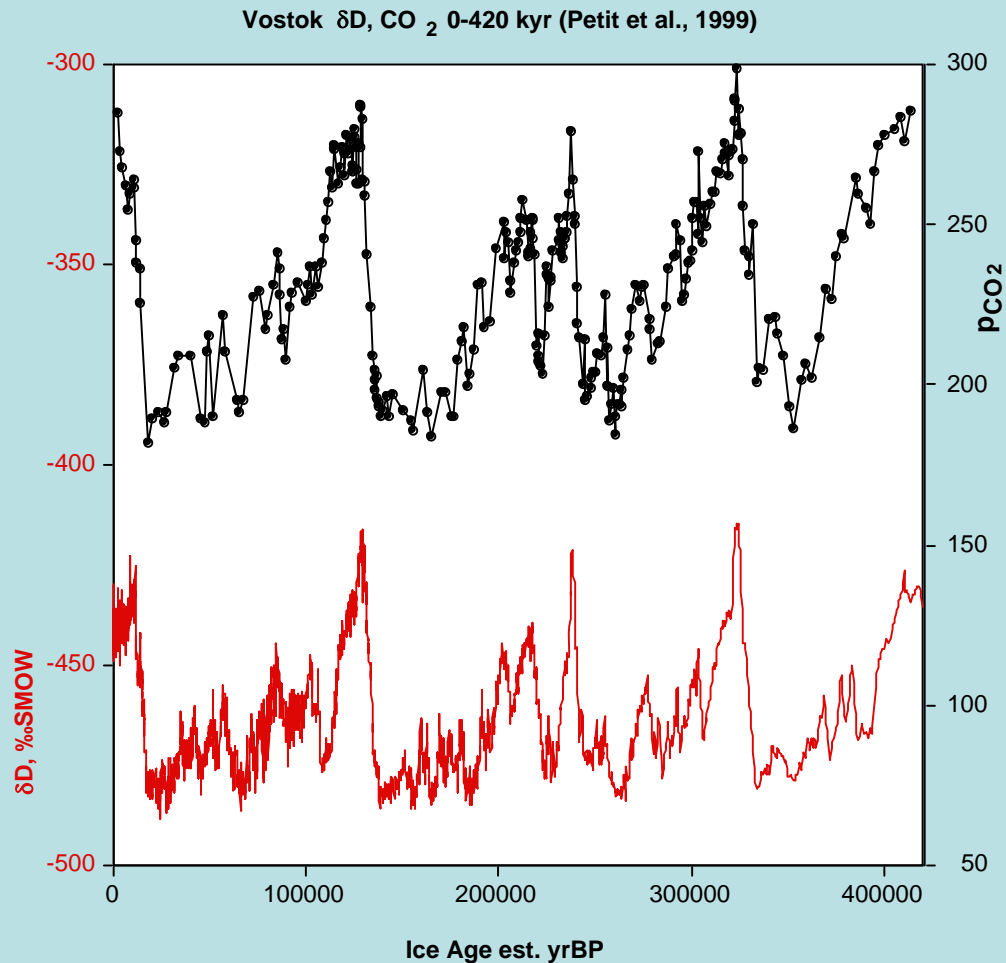

- In the early 1980's, it seemed that the Dye 3 Greenland ice core showed relatively large, rapid (few hundred year) fluctuations in CO₂ during glacial stadial/interstadial fluctuations. These were not observed in the high resolution Byrd Antarctic ice core, and it is now thought that these apparent high CO₂ events were artifacts due to melt layers or interactions with dust.
- So why did atmospheric CO₂ change with the glacial/interglacial cycles? Is the CO₂ change a chicken or an egg in the progression of climate change?
- Many ideas have been proposed; almost an equal number have been disposed of (or is it deposited?). Speaking informally, it is as if theories on glacial/interglacial carbon dioxide are radioactive with ~2 year half-lives.
- Despite this situation, there is much to be learned about CO₂ in the ocean from those ideas, so a historical examination of them is still worthwhile.

Digression: physical chemistry of CO₂ in the ocean 1

A. Two useful conservative quantities (properties that mix linearly) are:

$$\Sigma\text{CO}_2 = [\text{CO}_2(\text{aq})] + [\text{HCO}_3^-] + [\text{CO}_3^{=}]$$

$$\begin{aligned} \text{Alkalinity} = & [\text{HCO}_3^-] + 2[\text{CO}_3^{=}] \\ & + [\text{B}(\text{OH})_4^-] + [\text{OH}^-] - [\text{H}^+] \\ & + (\text{etc...}) \end{aligned}$$

"Alkalinity" is a re-arranged charge balance equation which divides ions into those that have acid-base reactions and those that don't:

e.g., in a system consisting of a solution of NaCl, MgSO₄, NaCO₃, and NaHCO₃:

$$\begin{aligned} [\text{Na}^+] + 2[\text{Mg}^{++}] - 2[\text{SO}_4^{=}] &= [\text{HCO}_3^-] + 2[\text{CO}_3^{=}] + [\text{OH}^-] - [\text{H}^+] \\ &= \text{Alkalinity} \end{aligned}$$

Adding or removing CO₂ from a water sample does not change the alkalinity (convince yourself of this!)

Digression: physical chemistry of CO₂ in the ocean 2

D. Relevant equilibria ("apparent" thermodynamic constants). Because seawater is a "high ionic strength" solution (i.e., it is very salty), conventional thermodynamic constants (activity coefficients, etc.) are difficult to define because of strong ionic interactions. But because the composition of seawater (for major ions) is constant save for variations in total salt content, we can adopt "apparent constants" which incorporate the activity coefficients and ion interactions into the "apparent" constant (denoted by '):

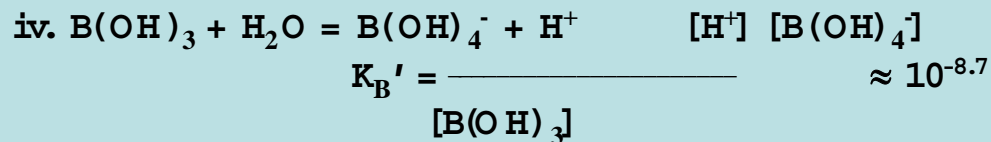
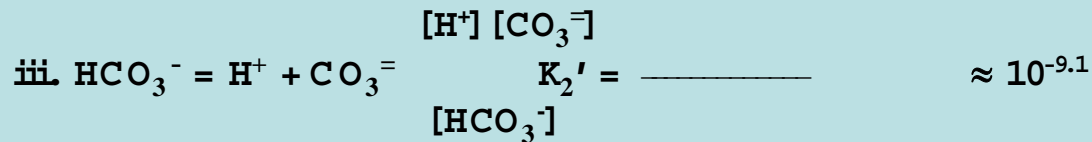
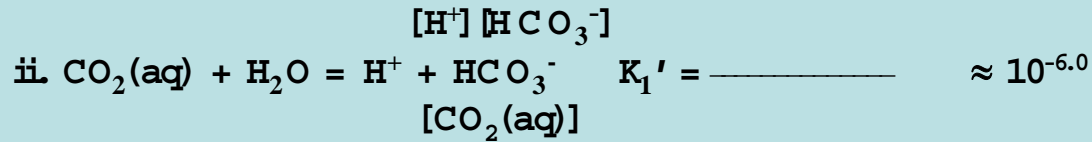
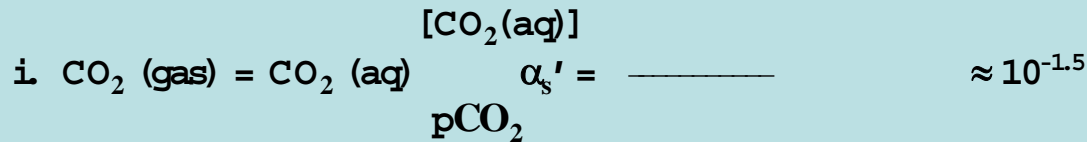

These apparent constants are functions of temperature, salinity, and pressure.

Variables:

pCO₂

[CO₂(aq)]

[HCO₃⁻]

[CO₃⁼]

[B(OH)₃]

[B(OH)₄⁻]

[H⁺]

T

S

9 variables

Knowns:

4 equations

T

S

ΣB / S

2 specified parameters

(e.g. Alk, ΣCO₂)

9 equations or specified

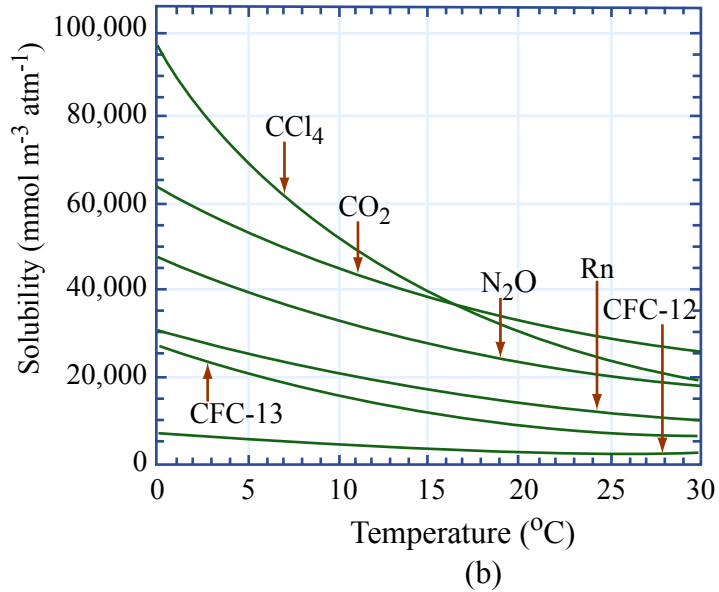
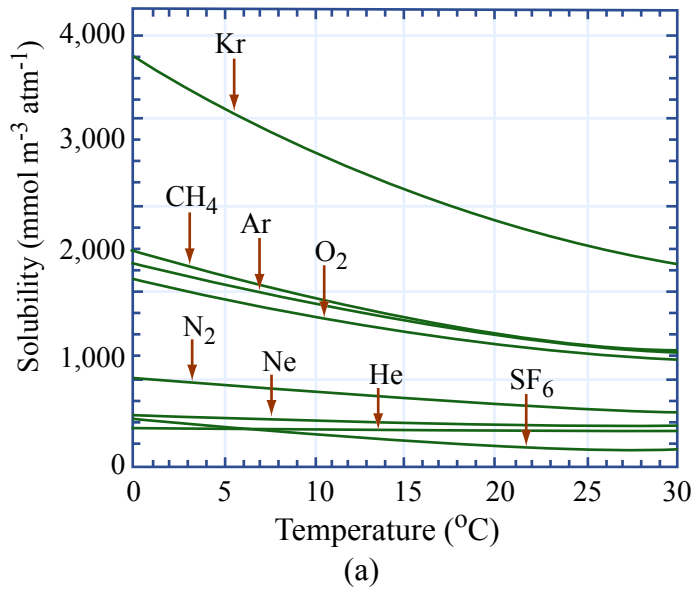

Plot of the solubility of various gases as a function of temperature. The solubility of all gases decreases with increasing temperature, but there exist large differences in the solubility of the different gases for a particular temperature. These differences can be understood in terms of their molecular weight (ideal gas) or other factors, such as molecular interactions between the gas and the water (nonideal gas). Note the change in vertical scale between panels (a) and (b). Based on the empirical functions listed in table 3.2.2.

Figure by MIT OpenCourseWare based on Sarmiento and Gruber (2006).

The Revelle Factor

Revelle Factor $R = \frac{\Delta p_{\text{CO}_2} / p_{\text{CO}_2}}{\Delta \Sigma \text{CO}_2 / \Sigma \text{CO}_2} \sim 10$

CO₂ (gas)

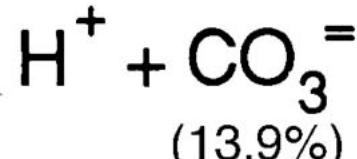
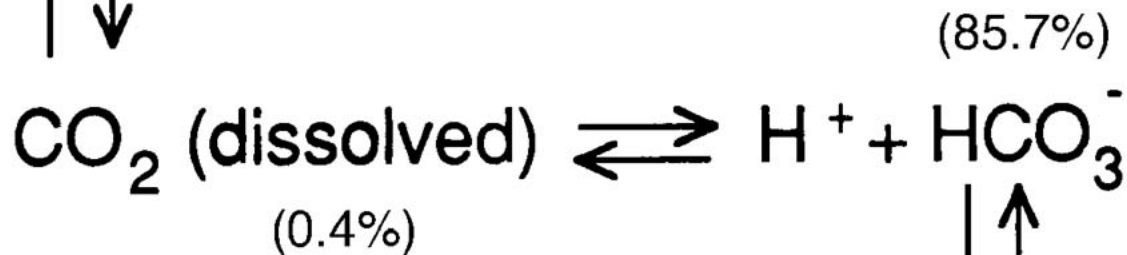

Typical values of carbonate species

For example, for values of Alk and ΣCO_2 typical of pre-anthropogenic warm surface waters (Alk=2275, $\Sigma\text{CO}_2=1900$; pH=8.3; $p_{\text{CO}_2}=283$) and cold deep waters (Alk=2375, $\Sigma\text{CO}_2=2260$; pH=7.9):

units: ($\mu\text{mol/kg}$)

	[CO ₂ (aq)]	[HCO ₃ ⁻]	[CO ₃ ⁼]	Alk- ΣCO_2	[B(OH) ₃]	[B(OH) ₄ ⁻]
ws	8	1628	264	375	288	119
cd	27	2150	85	115	349	58

(ws = warm surface cd = cold deep)

In deep waters one can estimate $\Delta\text{CO}_3^{=} \approx 0.6 [\text{Alk}-\text{CO}_2]$

(because about 40% of an alkalinity increase converts B(OH)₃ to B(OH)₄⁻ rather than HCO₃⁻ to CO₃⁼)

Digression: physical chemistry of CO₂ in the ocean 3

Once the system of equations relevant to a problem have been set up (and these may include mass balance, alkalinity, or other constraints), they are solved generally by computer, where the underlying method involves substituting terms to create a single polynomial equation with [H⁺] as the only variable. This equation is then solved with Newton-Rapson or similar method. For the range of values appropriate for seawater, simplifications can be made that reduce this system of equations to a cubic polynomial with an exact solution. D. By expressing all species in terms of [H⁺], then combining into a single equation in [H⁺], it can be shown that

$$pH = f\left(\frac{Alk}{\Sigma CO_2}, (T, S, P)\right)$$

Assuming deviations within the range of values likely to be found in the ocean, the relationship can be expressed as a simple cubic equation which has an exact solution. Since the relative amount of the various CO₂ species is a function of the pH, we can compute the absolute amount of each species as f(pH)*ΣCO₂; or directly as f(Alk, ΣCO₂). The best formulation for CO₂ system calculations under natural conditions is to solve the cubic hydrogen ion equation approximation where Alk, ΣCO₂, and borate are taken into account:

Let $A = Alk/\Sigma CO_2$ and $B = \Sigma B/\Sigma CO_2$, let [H⁺] = the activity of hydrogen ion, and let K_1' , K_2' , and K_B' be the apparent constants in seawater at the appropriate temperature, pressure, and salinity; then:

$$0 = [H^+]^3 A$$

$$+ [H^+]^2 [K_1'(A-1) + K_B'(A-B)]$$

$$+ [H^+] [K_1'K_B'(A-B-1) + K_1'K_2'(A-2)]$$

$$+ [K_1'K_2'K_B'(A-B-2)]$$

CO₂ exchange between the ocean and atmosphere

Rate of exchange of CO₂ between ocean and atmosphere. Speaking in round terms, we can calculate the average rate at which CO₂ moves across the sea surface:

$$\sim 2000 \text{ m/yr} \quad * \quad \sim 10^{-5} \text{ moles/kg} \quad * \quad \sim 1027 \text{ kg/m}^3 \quad \approx \quad \sim 20 \text{ moles/m}^2/\text{yr}$$

piston velocity *aq. CO₂ conc.* *conversion factor*

Given that the upper 75 m of the water column (mixed layer) underneath a square meter contains 150 moles of carbon, full equilibration for carbon isotopes (e.g. ¹³C, ¹⁴C) can take some time (~10 years). p_{CO₂} equilibration takes less time however, because the pH shift induced by gas exchange shifts the water towards equilibrium (e.g., if water is supersaturated with respect to atmosphere, CO₂ is lost and pH of seawater rises and some aqueous CO₂ is lost to the bicarbonate pool. Hence p_{CO₂} is moved towards equilibrium both by loss of aqueous CO₂ to atmosphere and by loss of aqueous CO₂ to bicarbonate pool (this is related to the Revelle Factor).

Simple Gas Exchange
(e.g. O₂, Ar)

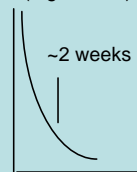

(depth of mixed layer divided by piston velocity - i.e. total gas content divided by gas flux)

pCO₂ equilibration

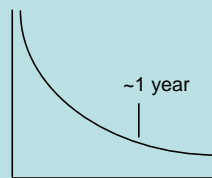

(change in TCO₂ required to change pCO₂ in seawater is divided by gas flux: e.g. for a 3% increase in pCO₂, CO₂(aq) rises by 3% and TCO₂ rises by 0.3%; but because TCO₂ is ~200x CO₂(aq), it then takes 200*0.3/3=20x longer)

carbon isotope equilibration
(C¹³, C¹⁴)

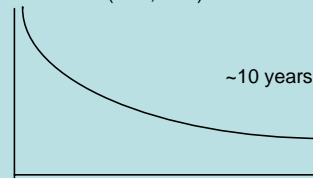

(total dissolved carbon dioxide divided by CO₂ gas flux, ~20 moles/m²/yr)

Global Carbon Fluxes

Image removed due to copyright restrictions.

The ocean CO₂ “pumps”

after Tyler Volk

Solubility Pump

- CO₂ is more soluble in cold water than in warm water

Biological Pump

- Organisms take up CO₂ in the euphotic zone, sink particles into deeper waters

Salinity Pump

- CO₂ is more soluble in fresher waters than in saltier waters

The solubility pump:

CO₂ is more soluble in cold waters than in warm waters. If alkalinity were uniform throughout the ocean and if both cold and warm surface waters equilibrated their p_{CO₂} with the atmosphere, then cold surface waters would have a higher dissolved carbon dioxide content than warm surface waters. As these cold surface waters circulate into the deep interior of the ocean, then deep waters will have more CO₂ than warm surface waters.

The biological pump

The biological pump: organisms remove carbon and nutrient elements from the surface ocean (which is equilibrated with atmospheric oxygen; note oxygen solubility is a function of temperature); the debris from these organisms sinks and decomposes, releasing carbon and nutrient elements into the deep water and consuming oxygen.

(Classical) Redfield Ratio:



This reaction represents elemental stoichiometries observed in ocean water samples and plankton. It considers marine organic matter as if it were a mixture of carbohydrates (CH_2O), proteins (containing NH_3), and phospholipids and nucleic acids (H_3PO_4 bearing). In reality, a broad mixture of compounds occur, and the stoichiometry of $\text{O}_2:\text{C}$ in particular $\Delta\text{O}_2/\Delta\text{C}$ in deep ocean waters implies a higher value (~ 165) due to more hydrocarbon-like functional groups:

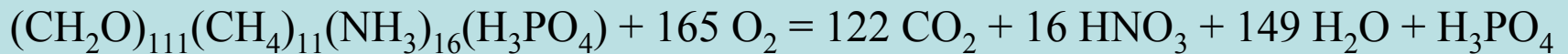

Note the production of nitric and phosphoric acid in this process; this acid creates changes in alkalinity. Once you acknowledge this process, you also need to take into account another effect that reduces the acid effect on alkalinity by about $1/3$: the presence of ion-exchanged carboxyl groups:

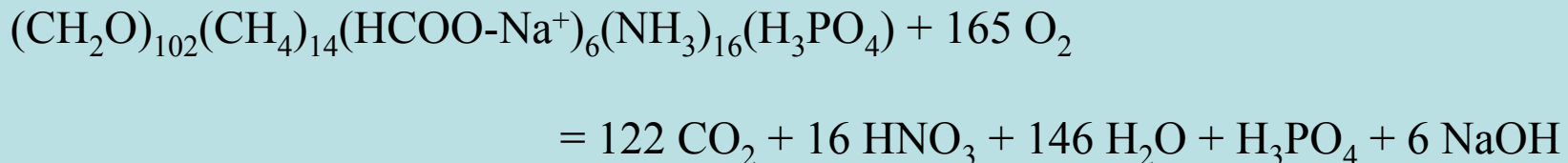

The solubility pump

CO₂ (and other gases) are more soluble in fresher waters than in saltier waters.

A few concepts advanced to explain low glacial CO₂

- Broecker (1982) sea level / shelf phosphorus transfer
- 3-group preformed phosphorus change
- Keir and Berger sea level / coral reef growth
- Boyle (1988) vertical nutrient shift
- Archer organic/inorganic “rain rate / sedimentary pore waters
- Broecker flexible C:N:P / increased N fixation
- Keeling sea-ice lid

Broecker (1982) sea level / shelf phosphorus interpretation of G/I p_{CO_2} and oceanic $\delta^{13}\text{C}$ evidence

- First, he discusses various mechanisms which might change p_{CO_2} . The shift must involve the ocean, because it is the dominant reservoir with which atmosphere communicates on $\sim 20,000$ year time scale. Salinity change (due to ice buildup) makes a small difference, as does temperature change (if you accept the CLIMAP T estimates); these latter cancel each other out. *[note: if you agree instead that tropical SST cooled a few degrees, then the effect of temperature is more significant]*
- Consider surface water as deep water which has warmed up, had its P removed by organisms (and accompanying removal of 106 CH_2O : 21 CaCO_3 : 16 NH_3 : 1 P)

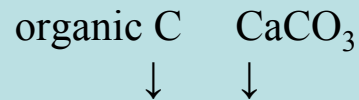

$$\text{CO}_2(\text{surface}) = \text{CO}_2(\text{deep}) - (106 + 21) * \text{P}(\text{deep})$$

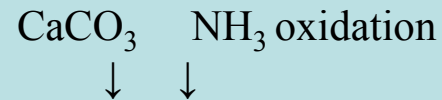

$$\text{Alk}(\text{surface}) = \text{Alk}(\text{deep}) - (2*21 - 16) * \text{P}(\text{deep})$$

$$\text{Surface } \Sigma\text{CO}_2 = 2260 - 2.2 * (106+27) = 1967$$

$$\text{Surface Alk} = 2375 - 2.2 * (54-16) = 2291$$

Broecker's 2-box interglacial ocean:

ATMOSPHERE

$P_{\text{CO}_2} = 324$

SURFACE OCEAN

$T = 22$ $S = 34.7$ $P = 0$ $\text{ALK} = 2291$ $\Sigma\text{CO}_2 = 1967$ $\delta^{13}\text{C} = 2.2$

$\text{CH}_2\text{O} : \text{CaCO}_3 : \text{NH}_3 : \text{P} = 106 : 27 : 16 : 1 ; \delta^{13}\text{C} = -20$

DEEP OCEAN

$T = 1$ $S = 34.7$ $P = 2.2$ $\text{ALK} = 2375$ $\Sigma\text{CO}_2 = 2260$ $\delta^{13}\text{C} = 0.0$

$[\text{CO}_3^{=}] = 85$

Broecker's 2-box glacial ocean:

ATMOSPHERE

$$P_{CO_2} = 241$$

SURFACE OCEAN

$T = 20$ $S = 35.9$ $P = 0$ $Alk = 2455$ $\Sigma CO_2 = 2040$ $\delta^{13}C = 2.2$

$CH_2O : CaCO_3 : NH_3 : P = 106 : 27 : 16 : 1 ; \delta^{13}C = -20$

DEEP OCEAN

$T = 1$ $S = 35.9$ $P = 3.2$ $Alk = 2577$ $\Sigma CO_2 = 2466$ $\delta^{13}C = -0.7$

$$[CO_3^{=}] = 88$$

(Assumes that marine organic matter from continental shelf is oxidized and put into ocean and that sedimentary $CaCO_3$ dissolves to keep $[CO_3^{=}]$ of deep ocean approximately constant)

Broecker's interglacial/glacial oceans:

Interglacial

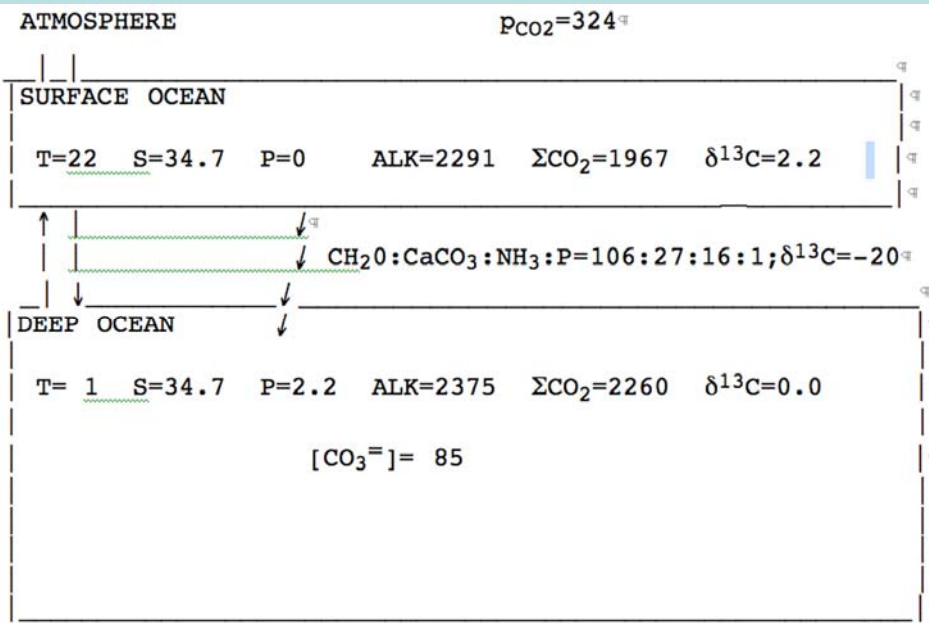

Glacial

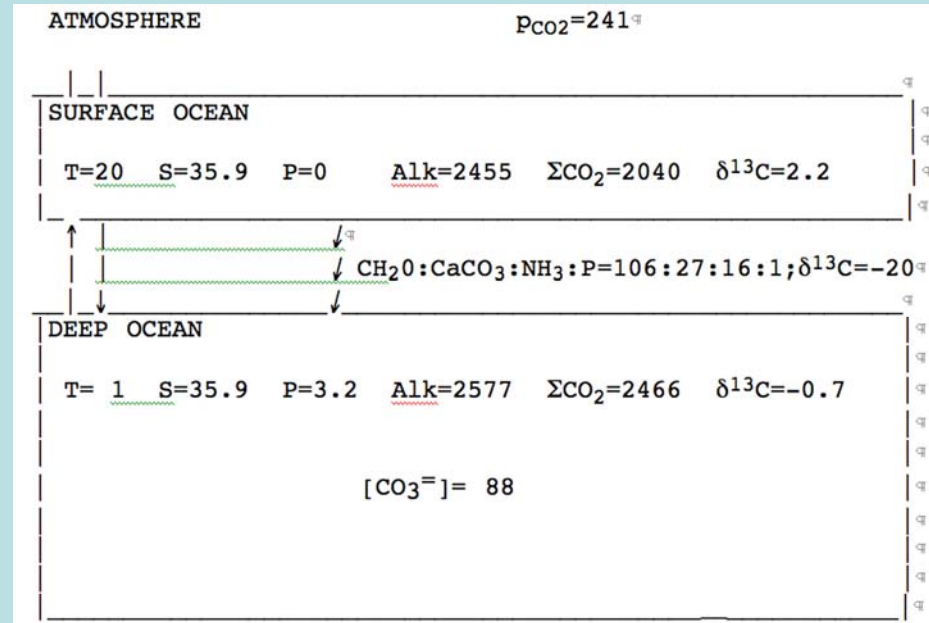

(Assumes that marine organic matter from continental shelf is oxidized and put into ocean and that sedimentary $CaCO_3$ dissolves to keep $[CO_3^{=}]$ of deep ocean is approximately constant)

Effect of Broecker's scheme on carbon isotopes

Take Deep Ocean Water:

Broecker, 1962

	CO ₂	Alk	P	¹³ C
Interglacial	2260	2375	2.2	0.0
Glacial	2473	2589	3.2	-0.7

Remove plankton, warm:

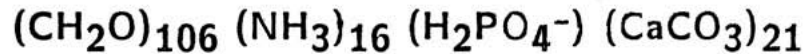

And you get warm surface ocean water:

	CO ₂	Alk	P	¹³ C
Interglacial	1980	2318	0.0	2.0
Glacial	2066	2505	0.0	2.0

$$\Delta \delta^{13}\text{C} \text{ (P-B)} = 2.0 \text{ (I)}$$

$$\Delta \delta^{13}\text{C} \text{ (P-B)} = 2.7 \text{ (G)}$$

with Glacial atmospheric CO₂ -90 ppm relative to Interglacial.

Problems:

1. $\delta^{13}\text{C}$ (P-B) changes before sealevel.
2. Cd data implies that P didn't change as much as that.
3. Deep ocean would go anoxic in large regions (contradicted by continuous presence of aerobic benthic fossils).
4. There probably isn't enough shelf organic carbon anyway.

Comparison to data:

- At the time, the calculated deep-sea $\delta^{13}\text{C}$ change was similar to the -0.7 permil suggested by Shackleton (1977) [although we now know that the change is less, about -0.3 to -0.4 ‰]
- Planktonic (surface) $\delta^{13}\text{C}$ does not change in model; this result was consistent with evidence available at the time [but data for planktonics had a relatively large scatter which raised some concerns].
- $\Delta^{13}\text{C}(\text{P-B})$ changes before CO_2
- One major problem with this model is that it would deplete the deep-sea of oxygen. This outcome clearly did not happen (as proven by the existence of glacial-age benthic foraminifera, which are aerobic organisms).
- global average oceanic Cd does not increase by 40% (Broecker and Peng assumed it would)

Shackleton and Pisias (1984) planktonic-benthic $\delta^{13}\text{C}$ record

Image removed due to copyright restrictions.

Toggweiler and Sarmiento (1984), Wenk and Siegenthaler et al. (1984), Knox and McElroy (1984) preformed phosphorus models for glacial CO₂

Three major deficiencies of the two-box ocean model are that:

- (1) It doesn't take into account high latitude processes (save for a gas-tight "chiller" that cools the water as it goes into the deep box). In reality, there is gas exchange between the high-latitude water and the atmosphere - leading to more CO₂ and higher oxygen concentrations in the sinking water.
- (2) It assumes that the sinking surface waters have near-zero nutrients; in actuality high latitude waters have significant levels of "pre-formed" nutrients. About 1/3 of the phosphorus arriving in the deep sea comes this way rather than from sinking particles, hence it did not contribute to the "biological pump"

estimation of **PFP** = **[P] - R[AOU]** where AOU is the apparent oxygen utilization and R is the P:O₂ Redfield Ratio

Toggweiler-Sarmiento (1984) 3-box model for interglacial / glacial CO₂

see also: Knox and McElroy, Wenk and Siegenthaler

This model suggests that the pre-formed nutrient content of polar surface waters decreases during glacial period (often pointing to increased high-latitude stratification as the mechanism for achieving higher nutrient utilization).

An alternative proposal for the mechanism of nutrient depletion is the “Martin Hypothesis” that says that Fe limits Antarctic productivity and that this limitation is diminished during glacial periods by a higher dust flux to polar regions (see ice core data).

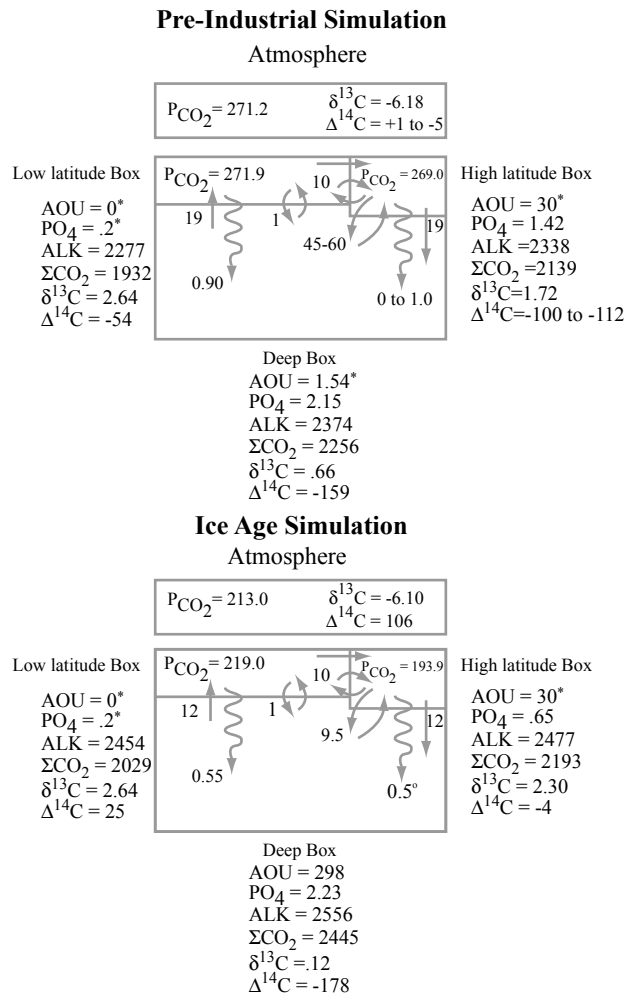

Steady state concentrations of model variables in the ocean and atmospheric boxes for the preindustrial and ice age simulations. Units are micromoles per kilogram for AOU, PO₄, and ΣCO₂; microequivalents per kilogram for alkalinity, parts per million for PCO₂; and parts per thousand (per mil) for δ¹³C and Δ¹⁴C. Model transports between boxes are given in units of sverdrups (10⁶m³/s). Particle fluxes are given next to the wiggly arrows in units of moles C per square meter per year. Asterisks indicate values that are initial assumptions.

Fig. 7. Steady state concentrations of model variables in the ocean and atmospheric boxes for the preindustrial and ice age simulations. Units are micromoles per kilogram for AOU, PO₄, and ΣCO₂; microequivalents per kilogram for alkalinity, parts per million for PCO₂; and parts per thousand (per mil) for δ¹³C and Δ¹⁴C. Model transports between boxes are given in units of sverdrups (10⁶ m³/s). Particle fluxes are given next to the wiggly arrows in units of moles C per square meter per year. Asterisks indicate values that are initial assumptions.

Construction of ocean chemical box models using matrices: the 3-box model as an example

- mass (of everything: salt, phosphorus, alkalinity, carbon) is strictly conserved.
- fluxes of water from box a to box b carry the chemical concentrations of water in box a
- particles can carry substances downward
- gases can move up through the ocean surface and back down into another part of the ocean surface.

Step 1: Salinity

Although it is of only minor relevance to the carbon system, the salinity distribution provides the easiest illustration of the model equations. The processes include mixing between boxes, and a transfer of water from low latitudes to high latitudes through the atmosphere. Underlying this salt balance is the water balance, where water fluxes in and out of each box must balance.

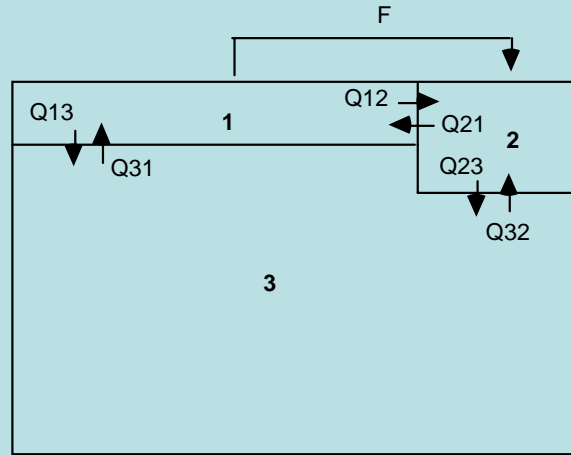

Consider the steady-state salinity mass balance for the high latitude box 2:

$$+Q_{12} S_1 - Q_{21} S_2 - Q_{23} S_2 + Q_{32} S_3 = 0$$

which can be slightly rewritten to:

$$+Q_{12} S_1 + (-Q_{21} - Q_{23}) S_2 + Q_{32} S_3 = 0$$

which can be expressed as a vector equation:

$$\begin{bmatrix} +Q_{12} & (-Q_{21} - Q_{23}) & +Q_{32} \end{bmatrix} \begin{bmatrix} S_1 \\ S_2 \\ S_3 \end{bmatrix} = 0$$

Step 1: Salinity

Writing the equations for boxes 1 & 2 and the overall mass balance equation in this form, and collecting them together into a matrix equation: the matrix formula describing this system of simultaneous equations is:

$$\begin{matrix} & \mathbf{A} & & \mathbf{x} & = & \mathbf{b} \\ \begin{bmatrix} -Q_{12}-Q_{13} & +Q_{21} & +Q_{31} \\ +Q_{12} & -Q_{21}-Q_{23} & +Q_{32} \\ +V_1 & +V_2 & +V_3 \end{bmatrix} & & \begin{bmatrix} S_1 \\ S_2 \\ S_3 \end{bmatrix} & & & \begin{bmatrix} 0 \\ 0 \\ S_{\text{tot}} \end{bmatrix} \end{matrix}$$

The first two equations describe the mass balances for boxes 1 and 2, and the third equation is the salt mass balance for the system as a whole (an equation for box 3 is not necessary or useful since it is a linear combination of the equations for boxes 1 and 2). Note that the atmosphere is assumed to have no salt and as no significant reservoir of water.

- discussion of units: water fluxes in the ocean are typically expressed as "Sverdrups", $10^6 \text{ m}^3/\text{sec}$. However, concentrations of chemicals are typically expressed in units of moles/kg. To keep the units consistent, we multiply water fluxes by the density of seawater, 1027 kg/m^3 . This conversion factor is an approximation, because the density of seawater depends slightly on temperature, salinity, and pressure, which must be taken into account for very precise applications.
- Also note that the average salinity of the ocean is tied to the mass of the ocean - changes in mean salinity are created by withdrawing water from the ocean into massive continental glaciers. Any model which assumes a change in mean ocean salinity has to include an inversely proportional change in the mass of the ocean, which will impact the concentrations of other dissolved chemicals.
- Another point to note is that our choice of the water fluxes and system volume as the master variables in "A" is a contextual choice; they could have been included as variables. In our case, the fluxes and volumes are chosen as master variables because they apply to all constituents - hence, once "A" is set up, it applies to all of the subsystems.

Step 2: phosphorus

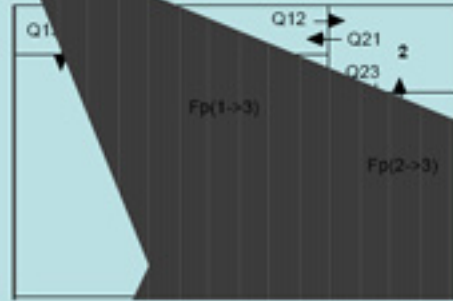

$$A \quad x = b$$

$$\begin{bmatrix} -Q_{12}-Q_{13} & +Q_{21} & +Q_{31} \\ +Q_{12} & -Q_{21}-Q_{23} & +Q_{32} \\ +V_1 & +V_2 & +V_3 \end{bmatrix} \begin{bmatrix} P_1 \\ P_2 \\ P_3 \end{bmatrix} = \begin{bmatrix} F_{P1} \\ F_{P2} \\ P_{tot} \end{bmatrix}$$

F_{P1} and F_{P2} are the fluxes of particulate biogenic phosphorus from boxes 1 and 2 into box 3, where they quantitatively decompose back into dissolved form ("regeneration"). The mass balance is:

$$\text{Advective Fluxes} + \text{Particle Fluxes} = 0 \quad (\text{for each box})$$

The sign of the particle flux in the b matrix for boxes 1 & 2 is positive because it has been moved from the left side of the equation to the right; e.g., the P equation for box one is:

$$+Q_{12} P_1 - Q_{21} P_2 - Q_{23} P_2 + Q_{32} P_3 - F_{P1} = 0$$

The particle flux is the negative term (at the end of the left hand side of the equation) switches sign when you move it to the right hand ("zero") side of the equation:

$$+Q_{12} P_1 - Q_{21} P_2 - Q_{23} P_2 + Q_{32} P_3 = F_{P1}$$

How do we derive the biological particle fluxes? Rather than model the biological system explicitly, we simply take observations (or hypotheses) of the phosphorus distribution in the ocean to constrain P_1 , P_2 , and P_{tot} (which sets P_3 from the mass balance). The equation is used to calculate F_{P1} and F_{P2} ($Ax=b$). Low-latitude surface water P is depleted to low concentrations by efficient biological uptake (in other words, P is the model "limiting nutrient"), and high-latitude surface water P is taken as a master variable to be explored. Note that it cannot be varied completely arbitrarily; some values might imply an upward flux of particles! Also, although the ocean phosphorus concentration is not mechanistically dependent on salinity, a withdrawal of water from the ocean (resulting in higher salinity) will increase the mean dissolved phosphorus concentration.

Step 3: alkalinity

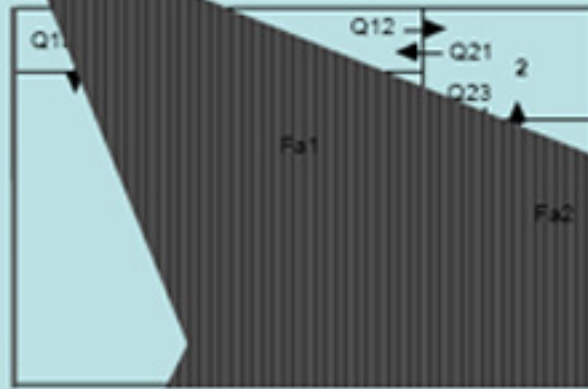

$$\begin{matrix}
 & A & & x & = & b \\
 \begin{bmatrix}
 -Q_{12}-Q_{13} & +Q_{21} & +Q_{31} \\
 +Q_{12} & -Q_{21}-Q_{23} & +Q_{32} \\
 +V_1 & +V_2 & +V_3
 \end{bmatrix} & & & \begin{bmatrix}
 A_1 \\
 A_2 \\
 A_3
 \end{bmatrix} & & \begin{bmatrix}
 f_{A1}F_{P1} \\
 F_{A2}F_{P2} \\
 A_{\text{tot}}
 \end{bmatrix}
 \end{matrix}$$

The alkalinity model is similar to the phosphorus model, except that the alkalinities are not fixed by observation or hypothesis but instead calculated after fixing the "Redfield" ratio particulate Alk/P ratios for the low- and high-latitude boxes. Note that alkalinity flux is mainly governed by the effect of calcium carbonate precipitation and dissolution and to a lesser extent by the oxidation/reduction of protein ammonia from nitrate. Alkalinity is also not transported/stored by the atmosphere!

Alkalinity is added to the ocean dominantly by the flux of CaCO_3 (limestone) dissolved on the continents and transported by rivers. It is removed from the ocean dominantly by the sedimentation of CaCO_3 . In considering changes to the carbon system over time, we require that the input of CaCO_3 and the output balance (over time scales of 5-10 kyr). In simple models such as this, this balance is often maintained by assuming that the deep carbonate ion concentration is constant.

Step 4: carbon dioxide

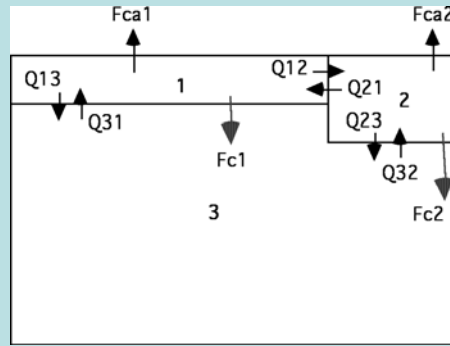

$$A \quad x = b$$

$$\begin{bmatrix} -Q_{12}-Q_{13} & +Q_{21} & +Q_{31} \\ +Q_{12} & -Q_{21}-Q_{23} & +Q_{32} \\ +V_1 & +V_2 & +V_3 \end{bmatrix} \begin{bmatrix} C_1 \\ C_2 \\ C_3 \end{bmatrix} = \begin{bmatrix} f_{C1}F_{P1}+F_{ca1} \\ f_{C2}F_{P1}+F_{ca2} \\ C_{tot}-p_{CO_2}M_{atm} \end{bmatrix}$$

The CO_2 model is similar to the alkalinity model, except that CO_2 is transported through the atmosphere and the atmosphere is a significant reservoir. The introduction of the atmosphere as a reservoir would best be handled by adding a fourth box (this is how it is implemented in the Excel spreadsheet; it makes the extension to C13 and C14 much easier). However, to stick to our simple 3-box formulation for this tutorial, we handle this issue simply by removing the carbon dioxide content of the atmosphere from the total contained in the ocean system (bottom term of b).

The particulate carbon flux is affected both by calcium carbonate formation/dissolution and organic matter formation/degradation. The fluxes of carbon dioxide between the ocean and atmosphere (F_{ca1} and F_{ca2}) are shown as both going into the atmosphere for the sake of consistent notation; at steady-state these will be equal to each other in magnitude but of opposite signs. Because p_{CO_2} and hence gas exchange fluxes are non-linear functions of Alk and CO_2 , it is necessary to solve this system by iteration; we guess atmospheric p_{CO_2} and air-sea fluxes, solve the linear system, and then modify the guesses iteratively until the system converges. Note also that because we are comparing fluxes calculated per unit of volume transfer (fluxes between ocean boxes) and fluxes calculated per unit of surface area (gas exchange as a function of the partial pressure difference between the ocean and atmosphere), it is especially important to make the units consistent.

Switch to 3-box model spreadsheet

Problems with the preformed phosphorus hypothesis

- Evidence for polar nutrient depletion is mixed; bulk sedimentary N isotopes support this idea but foraminiferal $\delta^{13}\text{C}$ and Cd/Ca do not.
- Although the 3-box model has less of a severe O_2 problem compared to the 2-box model, O_2 still decreases to very low levels, probably lower than we would expect given continuous benthic foraminiferal populations.
- The “Martin Hypothesis” Fe alternative may not get enough Fe increase to deplete nutrients year-round.

Coral-reef hypothesis

(Berger and Keir, Opdyke)

- The basic premise is that when sea level rises, coral reefs will grow upwards to reach the new sea-level, and increase pCO₂ from the reaction:

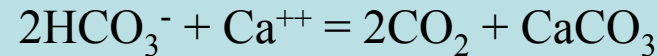

(Basically, this reaction removes alkalinity 2x the amount it removes ΣCO_2 , so it increases the Alk/CO₂ ratio, the pH rises, and the carbonate equilibria shift towards more aqueous CO₂.)

- In order to get this effect to be large enough to account for glacial CO₂, either one of two things must occur:
 - “Worthington’s lid” cuts off exchange between the surface water and deep water for fifteen thousand years. In 1959, Worthington proposed that the melting of glaciers lowered the salinity of surface waters and cut off exchange between the deep sea and the surface. In 2008, we have many proofs that this is not true, including the observation of anthropogenic transient tracers in the polar deep waters of both hemispheres, and the occurrence of levels of ¹⁴C not very different from today.
 - The deep ocean calcium carbonate system becomes incredibly out of whack, severely affecting carbonate sedimentation on the seafloor.
- Strike one, two, three, you’re out!

Boyle (1988) nutrient deepening hypothesis

- In the modern ocean, calcium-carbonate shell-forming organisms create CaCO_3 several times faster than rivers deliver weathered CO_2 to the ocean.
- This CaCO_3 sinks to the seafloor. Most of the seafloor is undersaturated with respect to CaCO_3 and so CaCO_3 dissolves.
- The ocean achieves a new steady-state balance with respect to carbonate weathering and sedimentation by adjusting the saturation state of the deep ocean to reach a balance between weathering and (formation-dissolution).

Nutrient deepening illustration

Step 1: Nutrient deepening

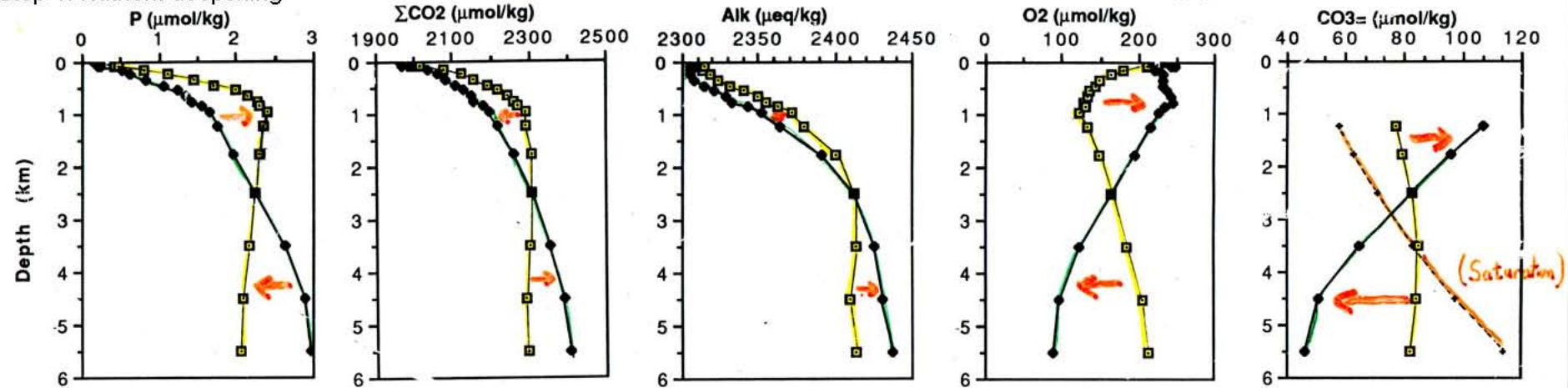

Step 2: carbonate compensation

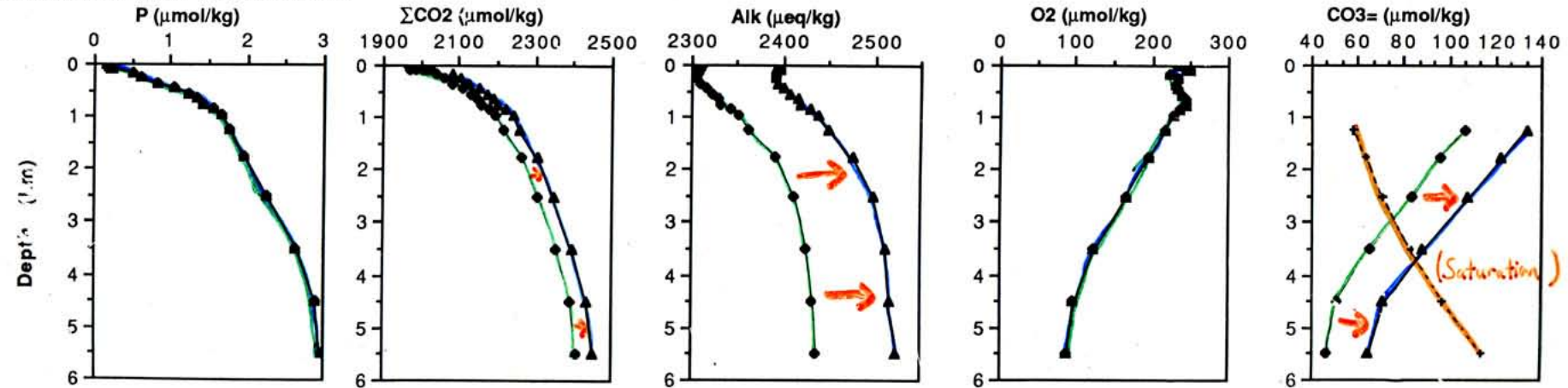

- Interglacial
- Pre-Glacial
- ▲— Eq. Glacial

Problem with the nutrient deepening hypothesis:

- Extent of nutrient deepening globally is probably not sufficient to account for a large fraction of total atmospheric CO₂ decrease (it's not clear that Pacific has strong nutrient deepening)
- Some ways of achieving nutrient deepening are not as efficient as others at reducing atmospheric CO₂

Archer and Maier-Reimer “rain ratio / sedimentary dissolution hypothesis

- Assumes that the “rain ratio” to seafloor of organic C:inorganic C increases
- The additional organic C decomposes in the sediment, leading to increased pore water dissolution of CaCO_3
- This leads to an imbalance in oceanic CaCO_3 input/output. $[\text{CO}_3^{2-}]$ increases until balance is restored.

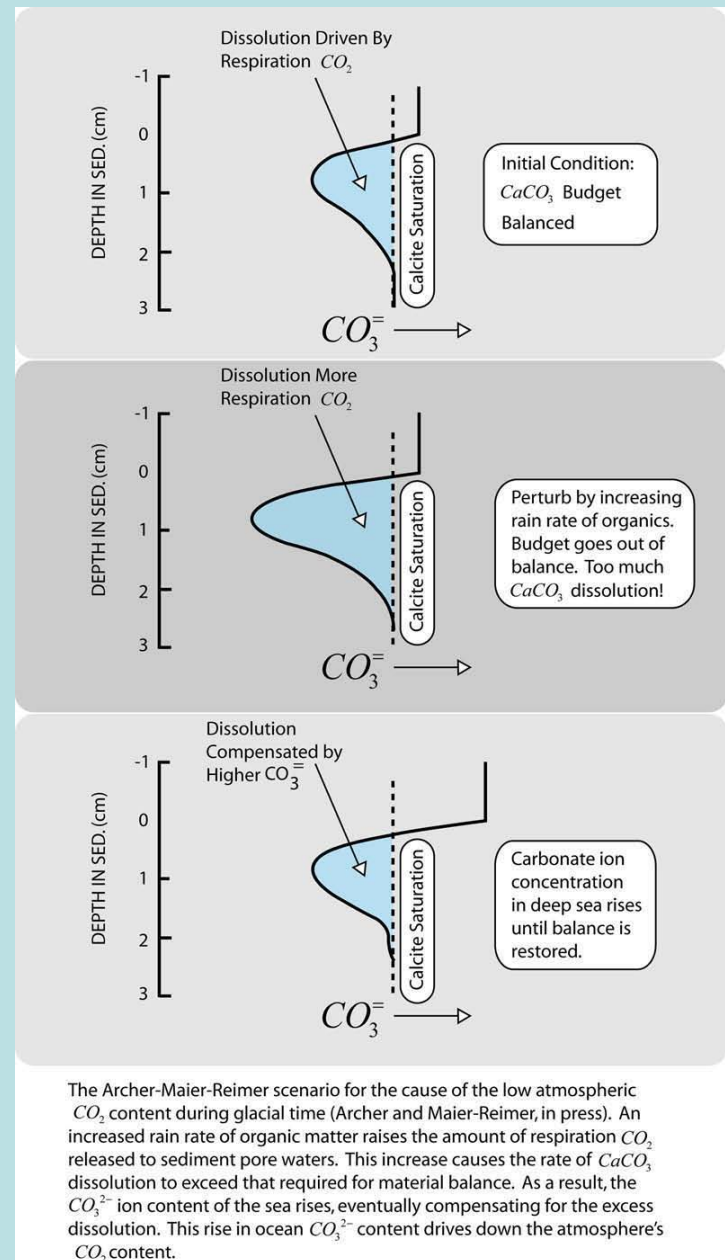

Figure by MIT OpenCourseWare. Adapted from source: Broecker (Glacial World According to Wally) concept from Archer and Maier-Reimer.

Problems with the “rain ratio” hypothesis

- How do we know if the “rain ratio” changed as specified?
- The big increase in oceanic $[\text{CO}_3^{=}]$ during glacial time should have left a CaCO_3 layer in glacial-age sediments of the deep Pacific ocean. This is not observed.

Two useful features of all the models that appeal to CaCO_3 compensation:

- CaCO_3 compensation has a lag time of 5-10 kyr. This could account for a lag of p_{CO_2} relative to $\Delta\delta^{13}\text{C}$.
- CaCO_3 compensation will produce dissolution pulse upon initiation of glaciation, preservation maximum upon deglaciation.

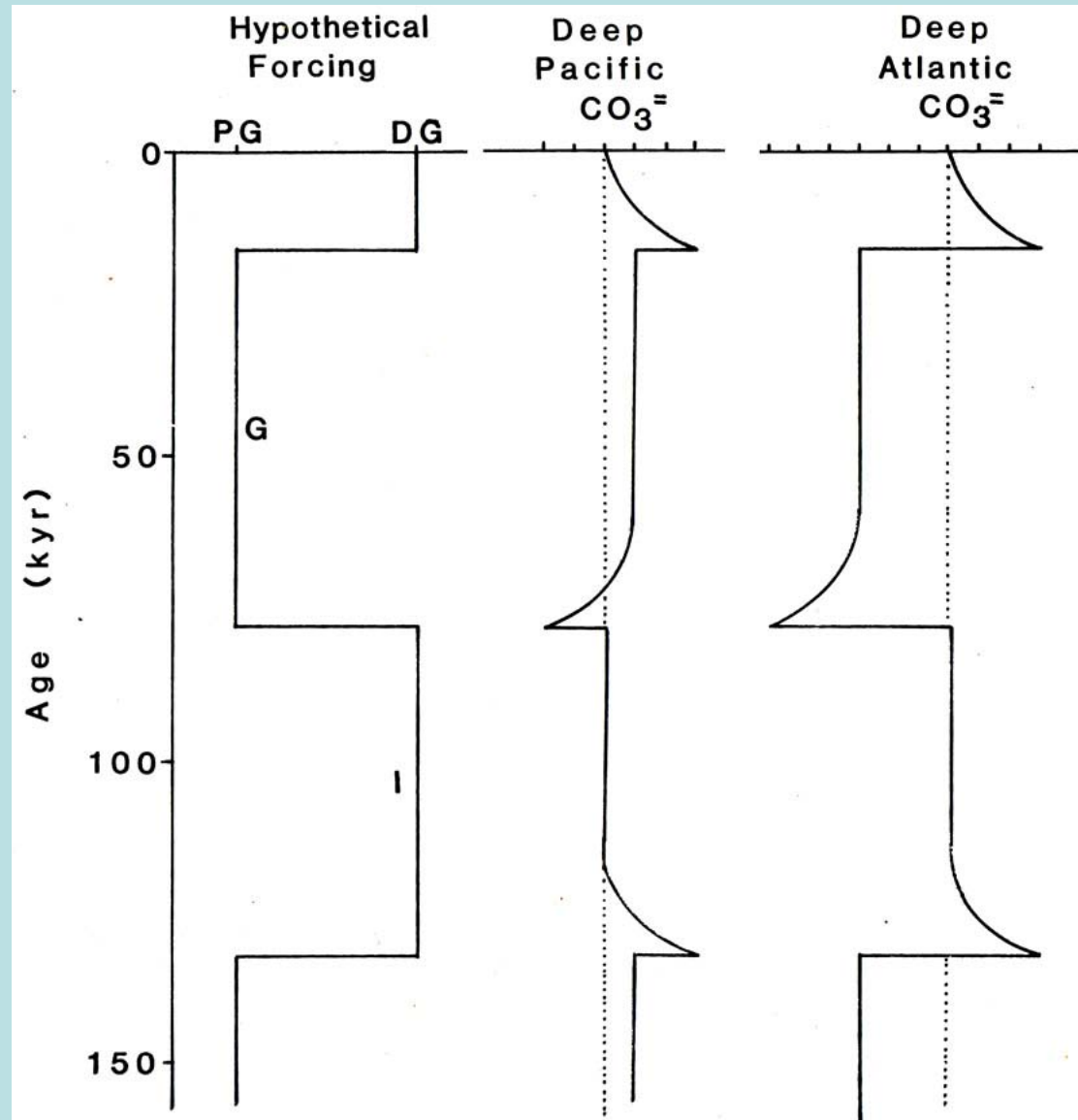

The nitrogen fixation / inventory hypothesis

(McElroy, Broecker, others...)

- This hypothesis assumes that N is the limiting nutrient (instead of P). In other words, that the C:N ratio is fixed but the C:P ratio is flexible.
- The residence time of NO_3^- in the ocean is on the order of thousands of years. If something perturbs the input/output balance, the nitrate concentration can respond relatively quickly.
- Things that could perturb the nitrate balance:
 - More dust, more N fixation (until oxygen loss increases denitrification)
 - Changes in ocean circulation that diminish the low- O_2 zones (inferred from $\delta^{15}\text{N}$ W. N. Pacific and Arabian Sea - possibly but not necessarily related to ocean nutrient deepening)
- Otherwise works the same as the “shelf phosphorus” model.

Problems with the nitrogen fixation / inventory hypothesis

- Is the Redfield ratio really that flexible (40%)? Most marine biologists think not...
- There are no nitrate paleoproxies - so we can't verify the effect with data.
- How is the balance between N fixation and denitrification re-established?

Keeling and Stephens sea-ice lid hypothesis

- The p_{CO_2} of the atmosphere would be lower if the polar regions didn't act as "leaks" in the biological pump.
- If sea ice nearly completely cut off gas exchange between the polar regions and the atmosphere, atmospheric CO_2 would be lower.
- Problem: the extent of complete sea ice coverage of the polar ocean would have to be extremely high.

Summary of the status of the glacial/interglacial CO₂ problem

- Step 1: transfer continental carbon into ocean as inferred from global mean $\delta^{13}\text{C}$. Initially this *increases* p_{CO_2} by 45 ppmV. After CaCO₃ compensation, this will decrease to ~15 ppmV
- Step 2: cool sea surface temperatures (2.5°C in polar regions, 5°C in lower latitudes (this is probably an overstatement)). This would decrease p_{CO_2} by 30 ppmV.
- Step 3: increase ocean salinity by 3% (1.2 ‰ PSS). This increases p_{CO_2} by ~6.5 ppmV.
- Steps 4 and above: combine all of the plausible models in some mixture that avoids the observable problems with any of them individually.

Reading (1)

Archer D. ,and Maier-Reimer E. (1994) Effect of deep-sea sedimentary calcite preservation on atmospheric CO₂ concentration. *Nature*. 367, 260-263.

*Barnola, J.M., D. Raynaud, Y.S. Korotkevich, and C. Lorius (1987) Vostok ice core provides 160,000 year record of atmospheric CO₂, *Nature* 329:408-414.

Boyle, E.A. (1988) The role of vertical chemical fractionation in controlling late Quaternary Atmospheric Carbon Dioxide, *J. Geophys. Res.* 93:15701-15714.

Broecker, W.S. (1982) Glacial to Interglacial Changes in ocean chemistry, *Progr. Oceanogr.* 11: 151-197

Broecker, W.S. (1982) Ocean chemistry during glacial time, *Geochim. Cosmochim. Acta* 46:1689-1705.

Brzezinski, M. A., C. J. Pride, et al. (2002). "A switch from Si(OH)₄ to NO₃-depletion in the glacial Southern Ocean." *Geophys. Res. Lett.* 29: doi:10.1029/2001GL014349.

Emerson, S. and D. Archer, Glacial carbonate dissolution cycles and atmospheric pCO₂: a view from the ocean bottom, *Paleoceanogr.* 7:319-331.

Hutchins, D. A. and K. W. Bruland (1998) Iron-limited diatom growth and Si:N uptake ratios in a coastal upwelling regime, *Nature* 393: 561-563.

J. Jouzel, C. Waelbroeck, B. Malaizé, M. Bender, J. R. Petit, N. I. Barkov, J. M. Barnola, T. King, V. M. Kotlyakov, V. Lipenkov, C. Lorius, D. Raynaud, C. Ritz and T. Sowers, (1996) Climatic interpretation of the recently extended Vostok ice records, *Clim. Dynamics*

Keeling-R.F. and B. B. Stephens-B.B. (2001) Antarctic sea ice and the control of Pleistocene climate instability, *Paleoceanography* 16:112-131

*Sigman, D. and E. Boyle (2000) Glacial/Interglacial variations in atmospheric carbon dioxide, *Nature* 407:859-869.

Stephens, B.B and Keeling-R.F. (2000) The influence of Antarctic sea ice on glacial-interglacial CO₂ variations, *Nature* 404:171-174

Keir R. S. ,and Berger W. H. (1985) Late Holocene carbonate dissolution in the equatorial Pacific: Reef Growth or Neoglaciation? In *The Carbon Cycle and Atmospheric CO₂: Natural Variations Archaen to Present* , *Am. Geophys. Union Mon.* (ed. E. T. S. a. W. S. Broecker)), Vol. 32, pp. 208-220.

Shackleton, N.J. et al. (1983) Carbon isotope data in core V19-30 confirm reduced carbon dioxide concentration in ice age atmosphere, *Nature* 306:319-322.

*Sarmiento, J.L. and R. Toggweiler (1984) A new model for the role of the oceans in determining atmospheric pCO₂, *Nature* 308:621-624.

Toggweiler, J R (1999) Variation of atmospheric CO₂ by ventilation of the ocean's deepest water, *Paleoceanogr.* 14:571

Carbon isotope equilibrium references:

Zhang, J., P.D. Quay, and D.O. Wilbur (1995) Carbon isotope fractionation during gas-water exchange and dissolution of CO₂, *Geochim. Cosmochim. Acta* 59, 107-114.

Emrich et al. (1970) *Earth Planet. Sci. Lett.* 8, 363-371 - but note they excluded their 20°C measurement as unreliable.

Gas Exchange reference:

Asher, W. and R. Wanninkhof (1998) Transient tracers and air-sea gas transfer, *J. Geophys. Res.* 103: 15939-15958.

Lynch-Stieglitz J., Stocker T. F., Broecker W. S., and Fairbanks R. G. (1995) The influence of air-sea exchange on the isotopic composition of oceanic carbon: observations and modeling. *Glob. Biogeochem. Cycles* 9, 653-665.

Reading (2)

Nitrate and nitrogen isotopes:

Altabet, M. A. and W. B. Curry (1989). Testing models of past ocean chemistry using foraminifera N15/N14, *Global Biogeochemical Cycles* 3: 107-120.

Altabet, M.A., R. Francois, D.W. Murray, W.L. Prell (1995) Climate-related variations in denitrification in the Arabian Sea from sediment 15N/14N ratios, *Nature* 373:506-509.

Brandes, J. A. and A. H. Devol (1997). "Isotopic fractionation of oxygen and nitrogen in coastal marine sediments." *Geochem. Cosmochim. Acta* 61: 1793-1801.

Brandes, J. A., A. H. Devol, et al. (2002), A global marine-fixed nitrogen isotopic budget: Implications for Holocene nitrogen cycling, *Glob. Biogeochem. Cycles* 16: 1120, 10.1029/2001GB001856

Falkowski, P.G. (1997) Evolution of the nitrogen cycle and its influence on the biological sequestration of CO₂ in the ocean, *Nature* 387:272

Ganeshram, R S; Pedersen, T F; Calvert, S E; Murray, J W, (1995) Large changes in oceanic nutrient inventories from glacial to interglacial, *Nature* 376:755