

Massachusetts Institute of Technology
Department of Aeronautics and
Astronautics
Cambridge, MA 02139

16.01/16.02 Unified Engineering I, II
Fall 2003

Problem Set 7

Name: _____

Due Date: 10/21/03

	Time Spent (min)
M2	
M3	
M4	
U3	
S7	
S8	
S9	
Study Time	

Announcements:

Problem M2 (Materials and Structures)

In this question you will calculate and sum forces and moments in 2-D

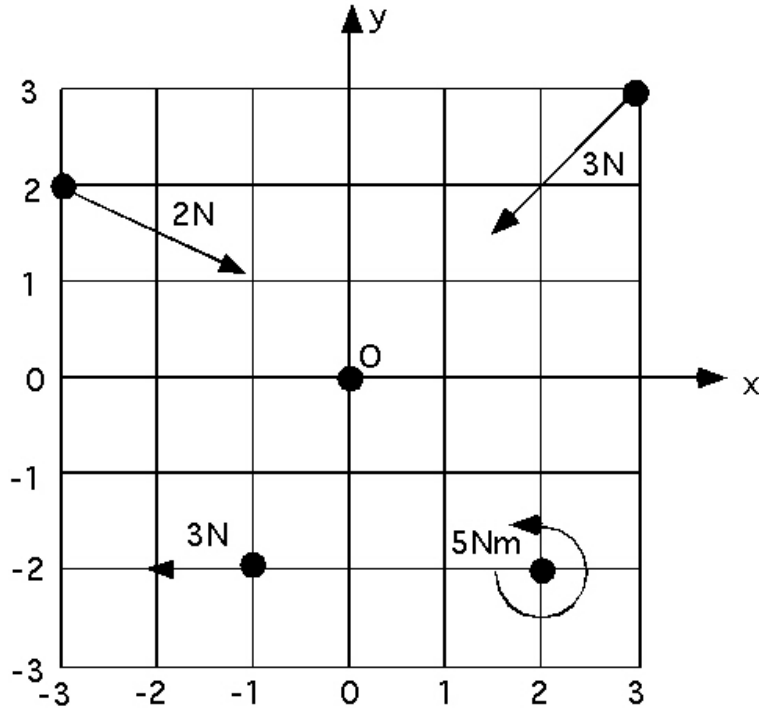

Consider the system of forces and couples acting in the directions indicated on the 6m x 6 m grid shown above. Calculate:

- (a) The total (resultant) force acting on the grid
- (b) The total moment acting about point O.

In each case express your answer as a vector.

Problem M3 (Materials and Structures)

In this question you are asked to examine equilibrium in 2-D

Referring back to the grid, and the applied forces and moments in question M2 determine whether the grid can be held in equilibrium by the application of the following combinations of additional forces and moments. In cases where equilibrium can be achieved express the necessary forces and moments as vectors. In cases where equilibrium cannot be achieved, explain why?

- a). The application of a force at O?
- b) The application of a moment at O?
- c) The application of a force and moment at O?
- d) The application of a pair of 20 N forces at $(-1,0,0)$ and $(+1,0,0)$. The forces do not necessarily have to act in parallel directions.

Problem U3 (Unified Concepts)

In this question you are asked to examine forces and moments as vectors in 3 D

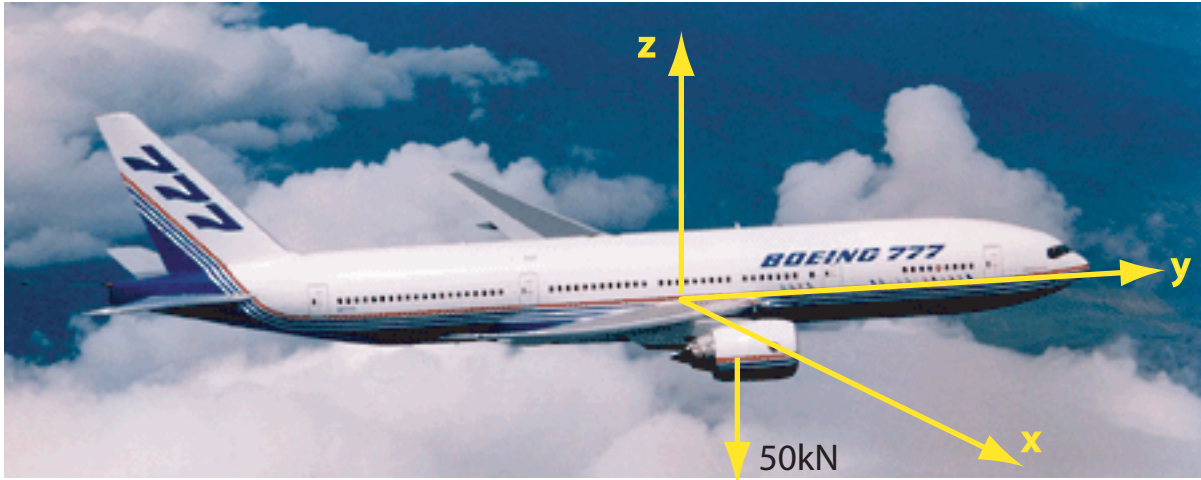

Image taken from NASA's website. <http://www.nasa.gov>.

A twin engine transport aircraft has its engines positioned such that their center of mass is forward of the wings. Each engine is attached by a strut. The wings are swept back at an angle of about 25° , and have a slight upward dihedral angle. Using a coordinate system centered on the starboard wing root (where the wing intersects the fuselage), the center of mass of the starboard engine is at a point with position vector $\frac{2}{3} \langle 1, 2, 1 \rangle$, m. The position vector of

the port wing tip, T, is $\frac{1}{2} \langle 14.0, 3.0, 2.0 \rangle$, m. The weight of the engine is 50000 N and acts vertically

downward through the center of mass. Answer the following questions, expressing your answers as vectors.

- What is the moment created by the weight of the port engine about the wing root?
- What is the component of this moment acting along the line OT?
- What is the component of this moment acting perpendicular to the direction of the wing?
- Physically what do the components of the moment you calculated in b) and c) do to the wing?

Problem M4 (Materials and Structures)

For the following two 2-D planar trusses, with the loading shown, draw a free body diagram and calculate all the reaction forces, showing them on the free body diagram.

a)

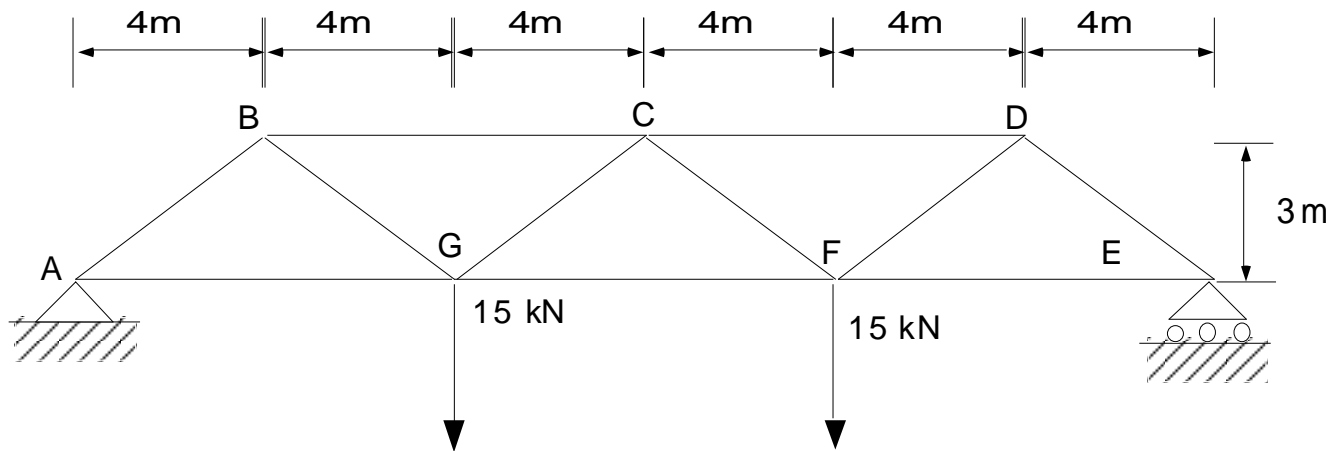

b)

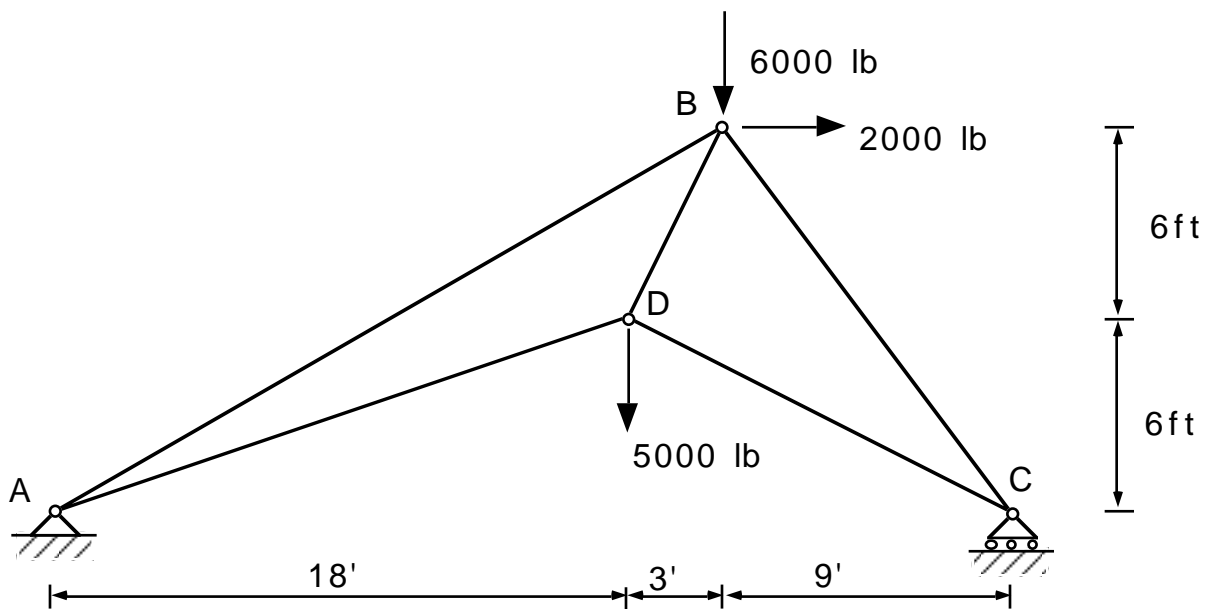

c) □

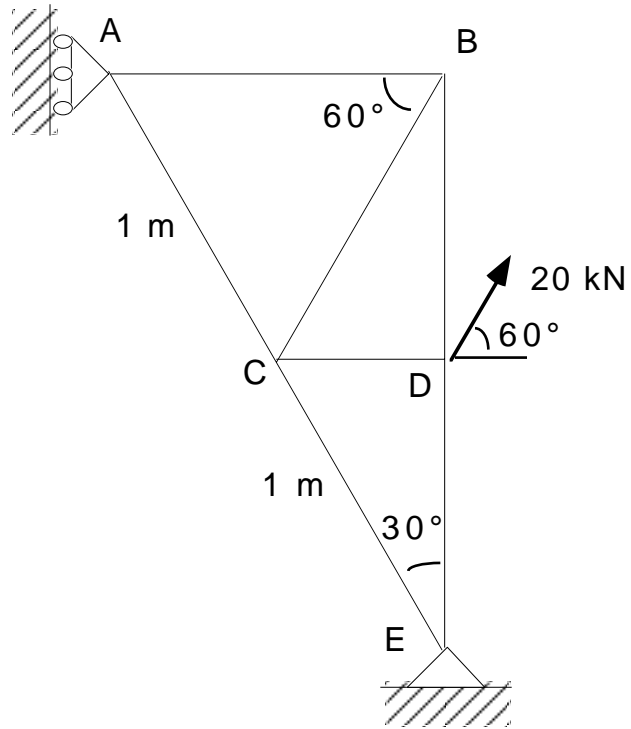

Problem S7 (Signals and Systems)

Find the Thevinin and Norton equivalent circuits for the circuits below. Hint: Add a test current to the terminals, and then determine the voltage at the terminals as a function of the test current. You should find that the terminal voltage can be expressed as

$$v = V_T + R_T I_{\text{test}}$$

1.

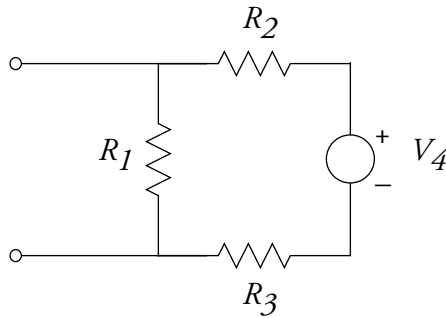

where

$$R_1 = 3 \Omega, \quad R_2 = 4 \Omega, \quad R_3 = 2 \Omega, \quad V_4 = 12 \text{ V}$$

2.

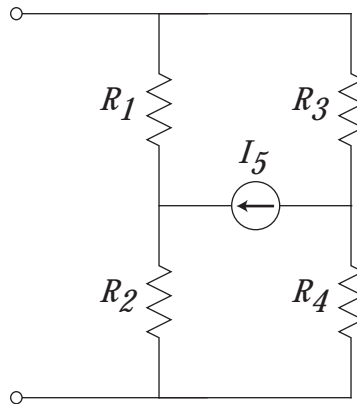

where

$$R_1 = 1 \Omega, \quad R_2 = 4 \Omega, \quad R_3 = 4 \Omega, \quad R_4 = 1 \Omega, \quad V_5 = 10 \text{ V}$$

Problem S8 (Signals and Systems)

1. Using the constitutive law for capacitors and inductors, derive the equivalent capacitance and inductance for the following series and parallel configurations:

a)

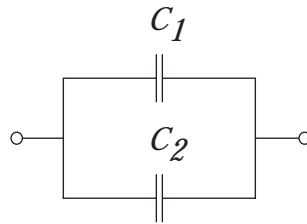

b)

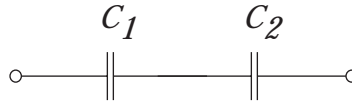

c)



d)

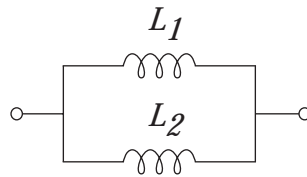

(Problem continued on following page.)

2. Find a set of differential equations that describe the dynamics of the circuit below, using the node method

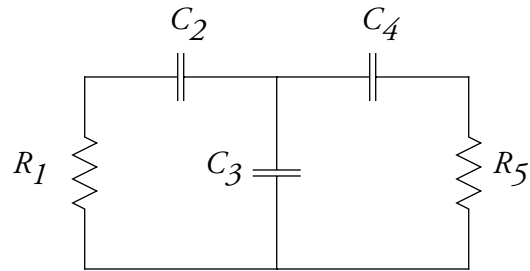

where

$$C_1 = 1 \text{ F}, \quad R_2 = 2 \text{ } \Omega, \quad C_3 = 2 \text{ F}, \quad C_4 = 4 \text{ F}, \quad R_5 = 5 \text{ } \Omega$$

Problem S9 (Signals and Systems)

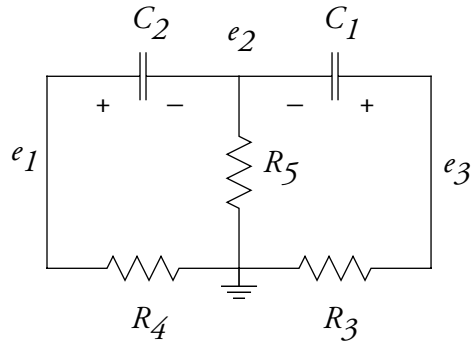

Consider the network above, with

$$C_1 = 1 \text{ F}, \quad C_2 = 2 \text{ F}, \quad R_3 = 2 \, \Omega, \quad R_4 = 1 \, \Omega, \quad R_5 = 1 \, \Omega$$

The capacitor voltages at time $t = 0$ are

$$v_1(0) = 10 \text{ V}, \quad v_2(0) = 0 \text{ V}$$

Find the capacitor voltages ($v_1(t)$, $v_2(t)$) as a function of time.