

6.0 Detailed vehicle description

6.1 Configuration

The F-111 had variable-sweep wings whose angles went from 16 degrees (full forward) to 72.5 degrees (full aft). The wingspan was between 63 ft and 33 ft respectively. This allowed the pilot to fly at the different regimes required: it could reach Mach 1.2 at sea level, Mach 2.2 at high altitude (up to 60,000 ft) with wings fully swept back, and nevertheless it could have a slow approach velocity (115 kts) with wings fully extended and then it could take off and land in about 2,000 ft.

For lower supersonic drag area-ruling concepts were used to pull together the engines at the rear of the airplane. The equivalent cross-sectional area distribution of the plane was close to the Sears-Haack rule.

Another particularity of the F-111 is that the two crewmembers sat side-by-side. The main reasons argued for this arrangement were allowing an optimum inter-crew communication and also avoiding the need of another plane to train new pilots. The cockpit also served as an escape module.

The F-111 could carry both conventional and nuclear weapons. To achieve a lower drag, it carried up two nuclear bombs in its internal bay, or it could replace them by additional fuel tanks for longer missions. It also could be equipped with M61 guns and could externally carry bombs, missiles and fuel tanks. A pivot system allowed the load nearest the fuselage to move in order to stay parallel to it when the wings swept.

Avionics of the F-111 were characterized by the Terrain-Following Radar, which was able to keep the plane flying at constant altitude, following the contours of the terrain. It could work day and night and for all weather conditions. The avionics system was also composed functions such as navigation, communication target acquisition, radar bombing for bad weather conditions, etc.

The airplane general arrangement shown in Figure 13.

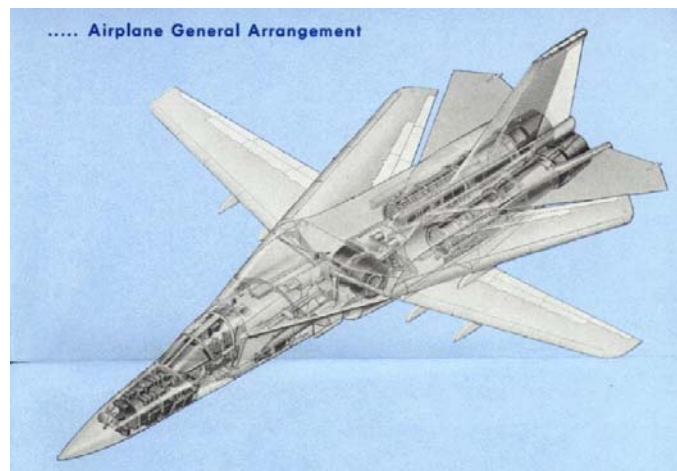

Figure 13: F-111 general arrangement [12]

6.2 Performance

6.2.1 Flight envelope and engine performance

Performance data from flight tests (F-111A performance document T.O. 1F-111(Y)A-1A) was not available for this study. The F-111A flight manual contains limited performance information on operating limitations, but all the data is estimated. The F-111F manual has operating limitations based on flight test, making it the best resource for performance charts. These performance charts can be supplemented with known F-111 performance numbers.

Altitude performance:

The F-111F altitude performance from the F-111F manual is shown in Figure 14.

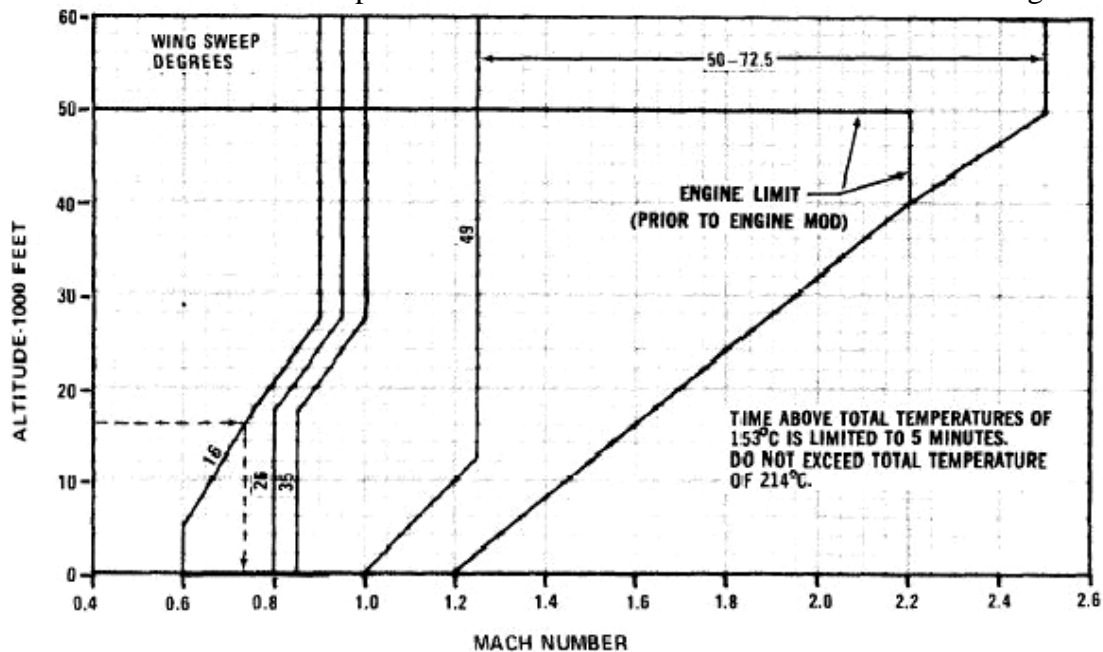

Figure 14: Altitude-speed performance of F-111F [13]

The 50,000 ft limit shown is not seen in published performance numbers. The ceiling for the F-111 was 60,000 ft. At 60,000 ft, the F-111A could operate up to 2.2 Mach, meeting the altitude requirement but failing the Mach 2.5 requirement. The figure also shows that the F-111 could fly at 1.2 Mach at sea level, fulfilling its requirement. Speed limitations in the figure are shown for various sweep angles as well.

Distance to clear a 50 ft obstacle:

Data on the distance to clear a 50 ft obstacle was not available, however the F-111 achieved its requirement of a less than 3,000 ft take-off run.

Load factor and airspeed limitations for F-111F:



Figure 15 shows the limit load factor in 'g's as a function of gross weight for various configurations and maneuvers. The different configurations are the following [13]:

- Flaps and gear up:
 - o (A) symmetrical maneuver at any wing sweep
 - o (B) asymmetrical (rolling pullout) maneuver
 - o (C) symmetric maneuver during wing sweep
- Gear up or down, slats only extended or flaps extended
 - o (D) symmetric maneuver (16-26 degrees wing sweep)
 - o (E) asymmetric maneuver (16-26 degrees wing sweep)

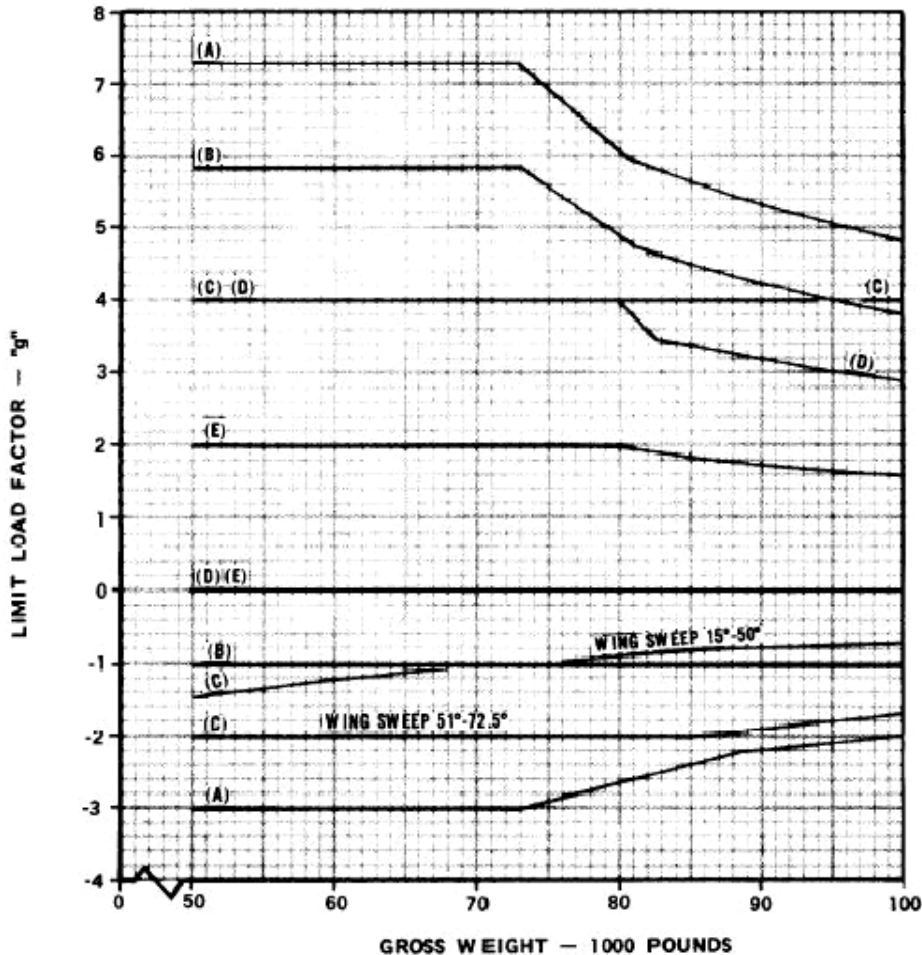

Figure 15: Load Factor as a Function of Weight for Various Configurations [13]

6.2.2 Missions

A quantitative way to determine with accuracy the performances of an aircraft is to analyze its capabilities in terms of mission. As explained in Section 5.4, the F-111 was

designed to accomplish a certain number of particular missions allowing it to penetrate into the Soviet territory.

6.2.2.1 Lo-Lo-Hi Mission

This mission is described in section 5.4.1 and is summarized on Figure 16. This aims at dropping a bomb at low altitude and coming back at high altitude and very high speed.

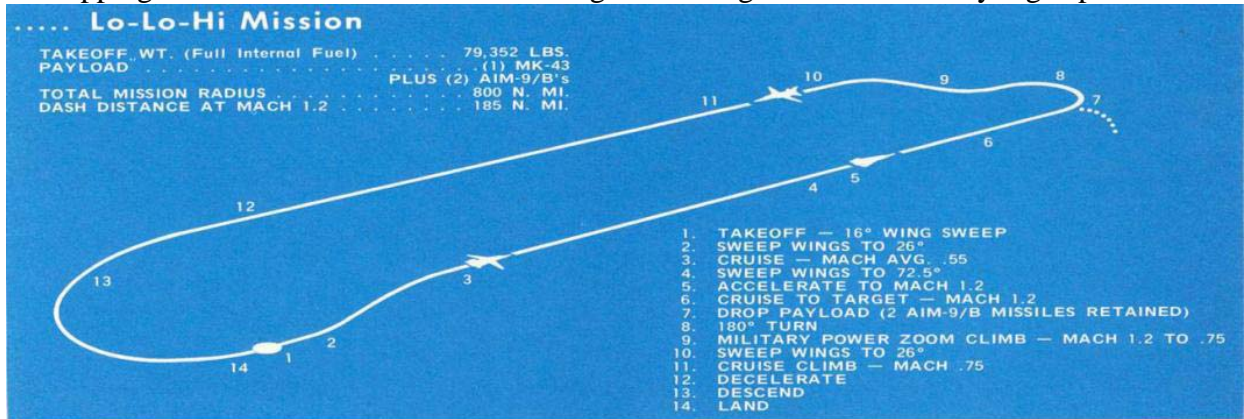

Figure 16: Lo-Lo-Hi Mission Profile [14]

As shown on Figure 17, the need for this mission is to be able to find a high performance tradeoff between the distance that you can reach at supersonic speed and low altitude (sea level dash distance) and the total mission radius. For a given total mission radius, the faster you fly, the smaller distance you can cover at high speed.

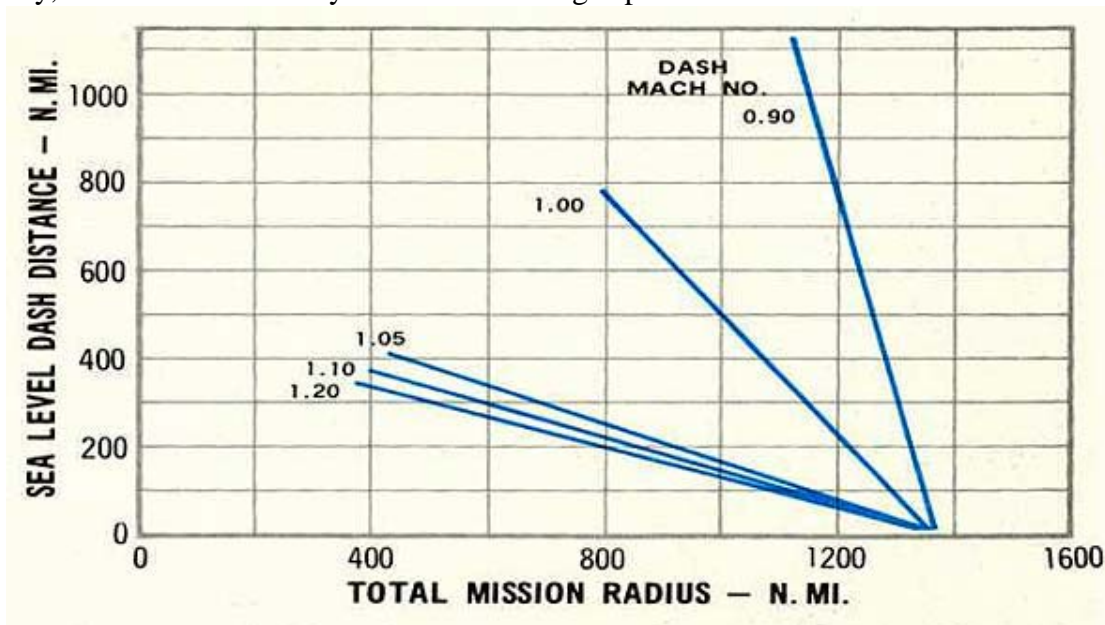

Figure 17: Tradeoff Between Sea Level Dash and Total Mission Radius [14]

The typical mission considered in the GD Proposal was an aircraft configured as in Figure 18: the airplane has one 2000 lbs nuclear weapon and two AIM-9/B (Sidewinder) air-to-air missiles mounted internally in the weapons bay.

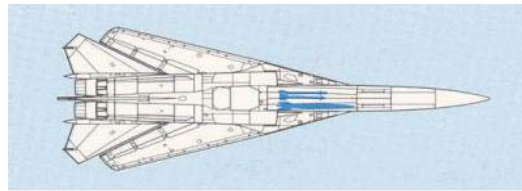

Figure 18: Lo-Lo-Hi Configuration [14]

In this configuration, the airplane is able to strike a target for a dash distance at Mach 1.2 of 185 N.Mi and a total mission radius of 800 N.Mi.

6.2.2.2 Lo-Lo-Lo-Lo Mission

It is the same kind of mission as the Lo-Lo-Hi one, but maintains low altitude throughout the mission (5.4.1). The mission is described in Figure 19.

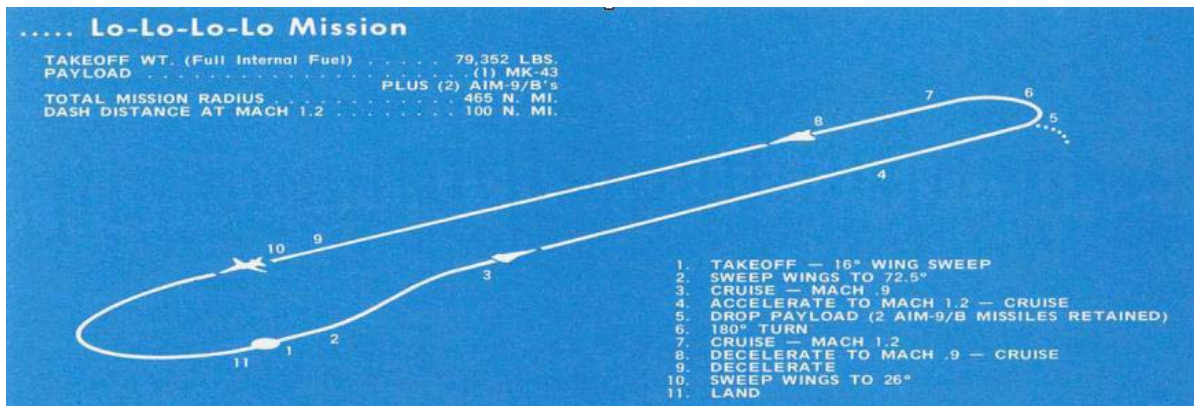

Figure 19: Lo-Lo-Lo-Lo Mission Profile [14]

The performance of this mission is measured by the combat zone radius (distance flown in supersonic flight) as a function of the total mission radius (Figure 20).

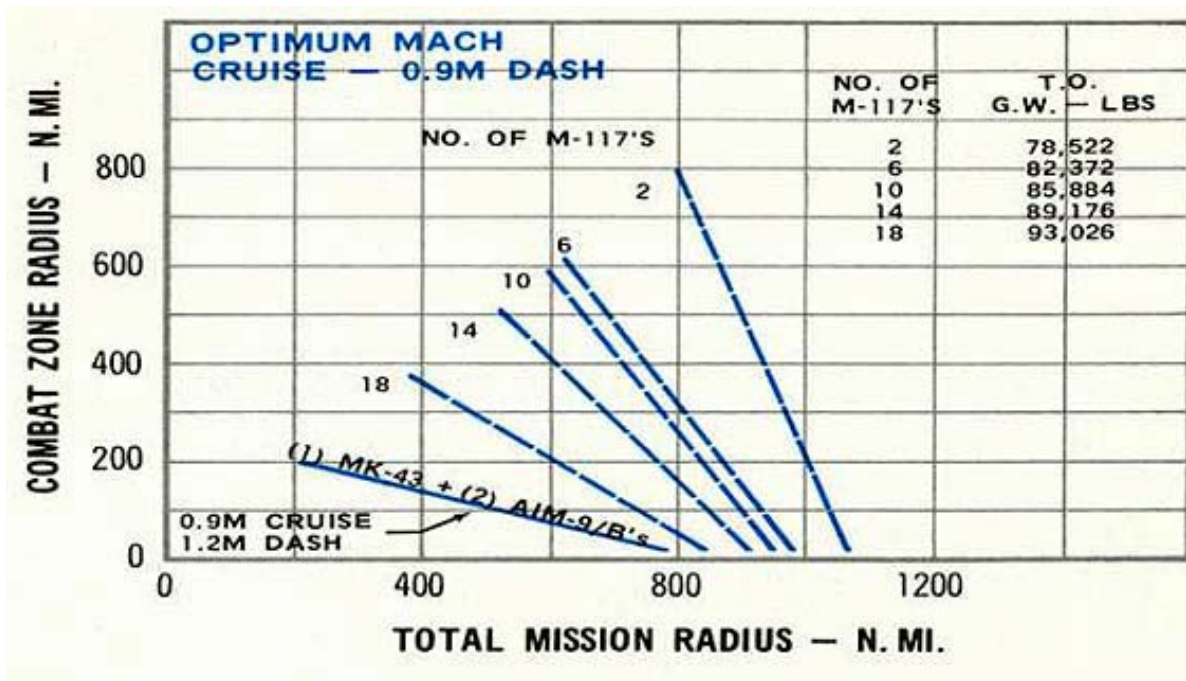

Figure 20: Tradeoff between Combat Zone Radius and Total Mission Radius [14]

Observations are the same as for Figure 17. F-111 can also carry M-117 missiles instead of nuclear weapons: then, increasing the payload decreases the combat zone radius. GD Proposal presents an airplane with the same configuration as for Lo-Lo-Hi mission (one 2000 lbs nuclear bomb and two AIM-9/B). For example, loaded as shown on

Figure 21 and for a total mission radius of 465N.Mi., the aircraft is able to strike a target for a dash distance at Mach 1.2 of 100 N.Mi.

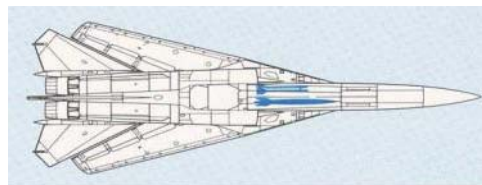

Figure 21: Lo-Lo-Lo-Lo Configuration [14]

6.2.2.3 Hi-Lo-Hi Mission

This is a conventional mission, which means that the airplane does not carry any nuclear weapon, but M-117 missiles. The cruises to the target and to return are done at high altitude, whereas the airplane delivers its payload at low altitude (Figure 22): the aircraft descends to sea level and a time of 3 minutes at military power is allowed for target acquisition. This mission has already been described in section 5.4.2.

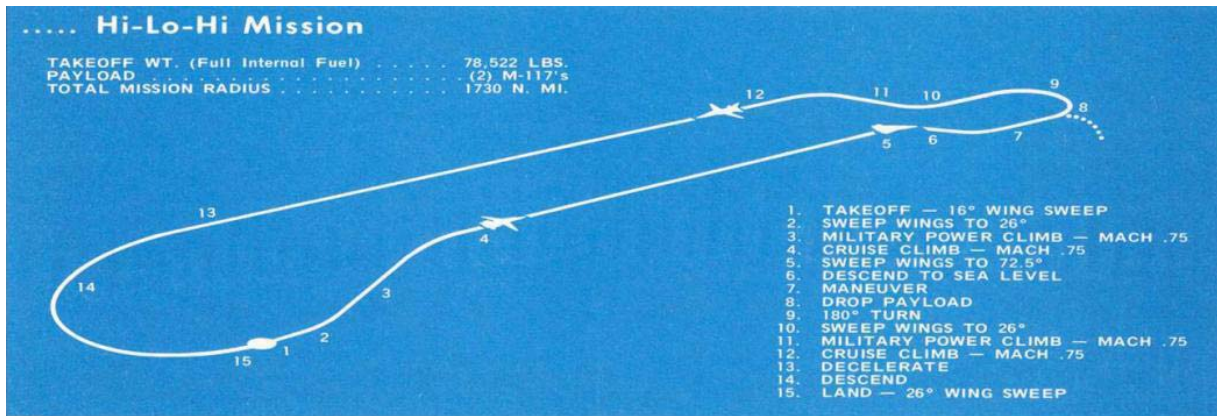

Figure 22: Hi-Lo-Hi Mission Profile [14]

The performance is given by the total number of M-117's as a function of the total mission radius (Figure 23). Obviously, when you increase the number of M-117 missiles, the payload is heavier and so the total mission radius decreases.

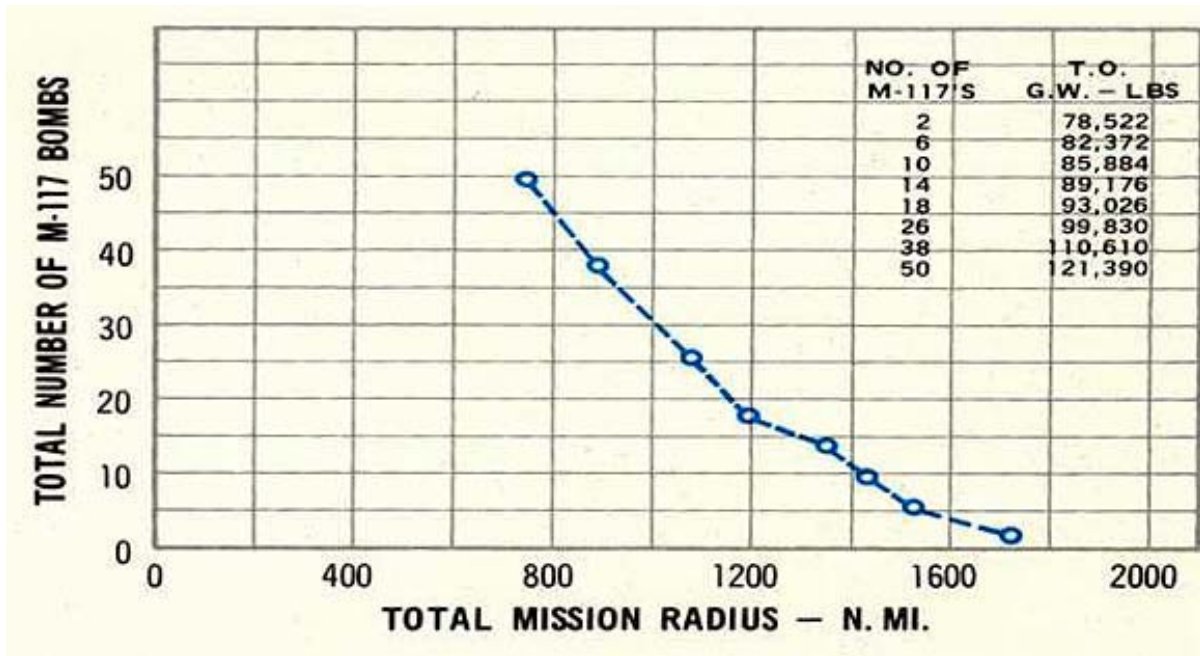

Figure 23: Tradeoff Between Number of Bombs and Total Mission Radius [14]

The proposed configuration is two M-117 general purpose bombs mounted internally in the weapons bay (Figure 24). An aircraft with such a configuration is able to accomplish a total mission radius of 1730 N.Mi.

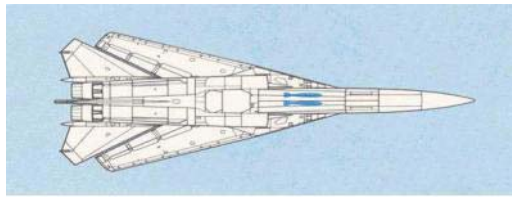

Figure 24: Hi-Lo-Hi Configuration [14]

6.2.2.4 Hi-Lo-Lo-Hi Mission

This mission is similar to the previous one, but dash to and from the target 200 nautical miles distance is accomplished at Mach 0.90 at sea level (Figure 25). This mission is described in section 5.4.2.

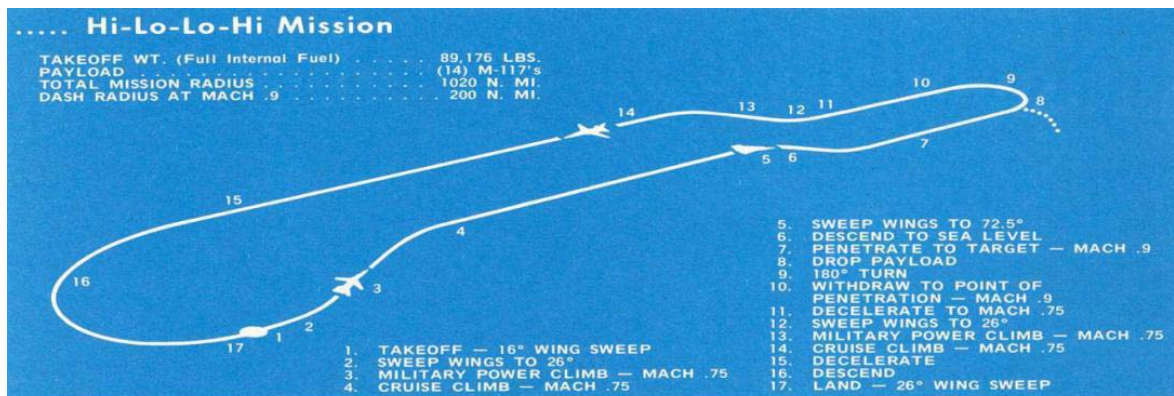

Figure 25: Hi-Lo-Lo-Hi Mission Profile [14]

The performance of the plane is expressed in terms of combat zone radius and total mission radius, depending on the payload (number of M-117's missiles on board). The results for F-111 are shown on Figure 26.

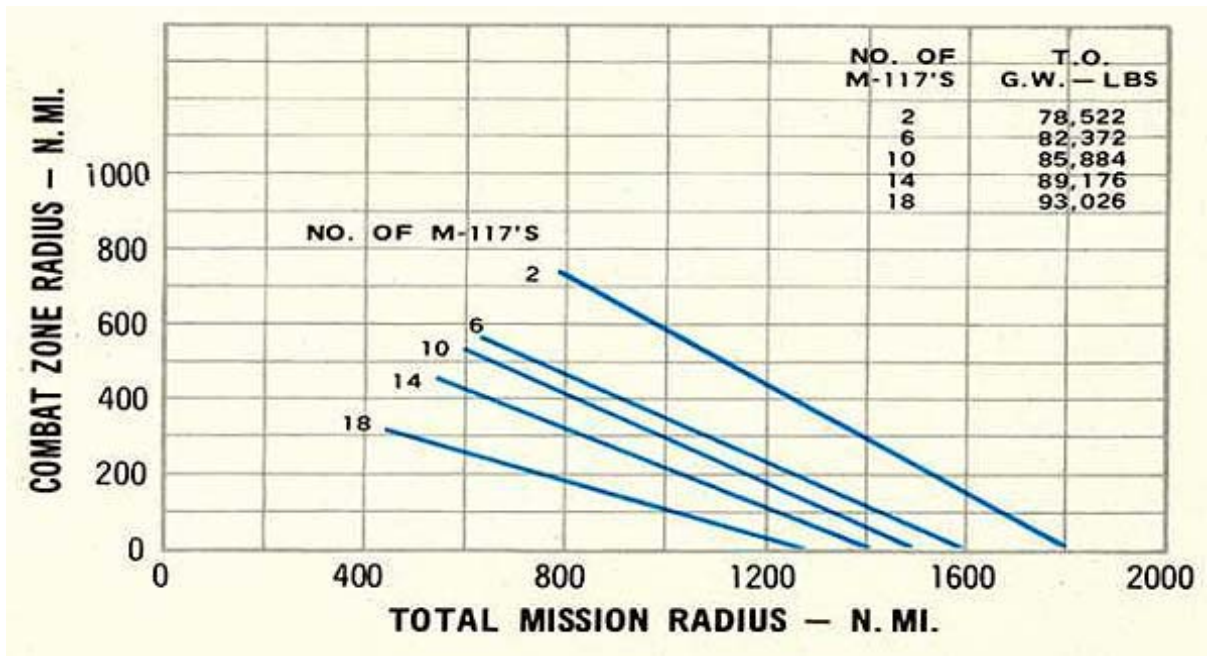

Figure 26: Tradeoff Between Combat Zone Radius and Total Mission Radius [14]

The typical configuration chosen by GD in its proposal is 14 M-117 general purpose missiles. Two are carried internally in the weapons bay and six are carried on each of the two outboard pivot pylons shown in Figure 27. For this kind of mission and configuration, the aircraft has a dash radius distance at Mach 0.9 of 200 N.Mi. for a total mission radius of 1020 N.Mi.

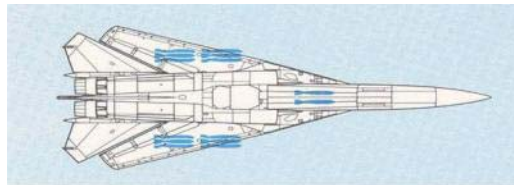

Figure 27: Hi-Lo-Lo-Hi Configuration [14]

6.2.2.5 Loiter Mission

This mission was required by the Navy (section 5.4.3). A description is given on Figure 28.

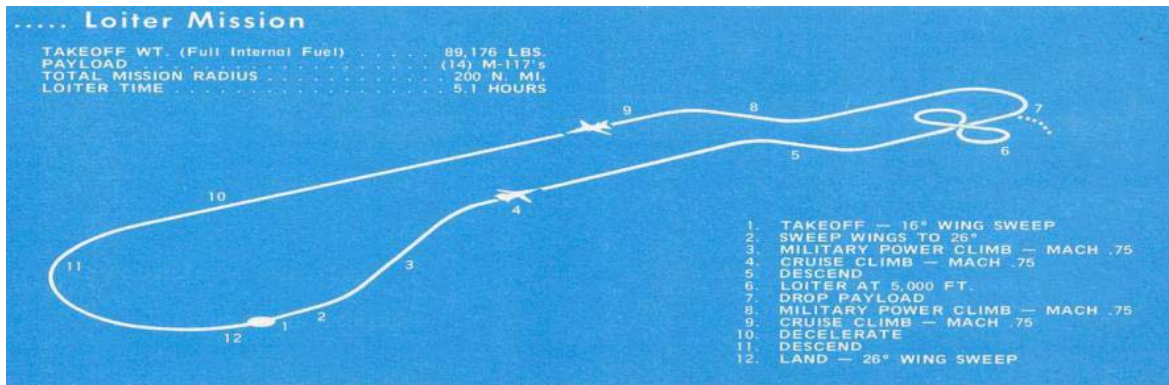

Figure 28: Loiter Mission Profile [14]

The loiter time as a function of the total mission radius for different numbers of M-117s is given by Figure 29. For a given total mission radius, this chart gives the decrease of loiter time when the number of M-117s missiles increases.

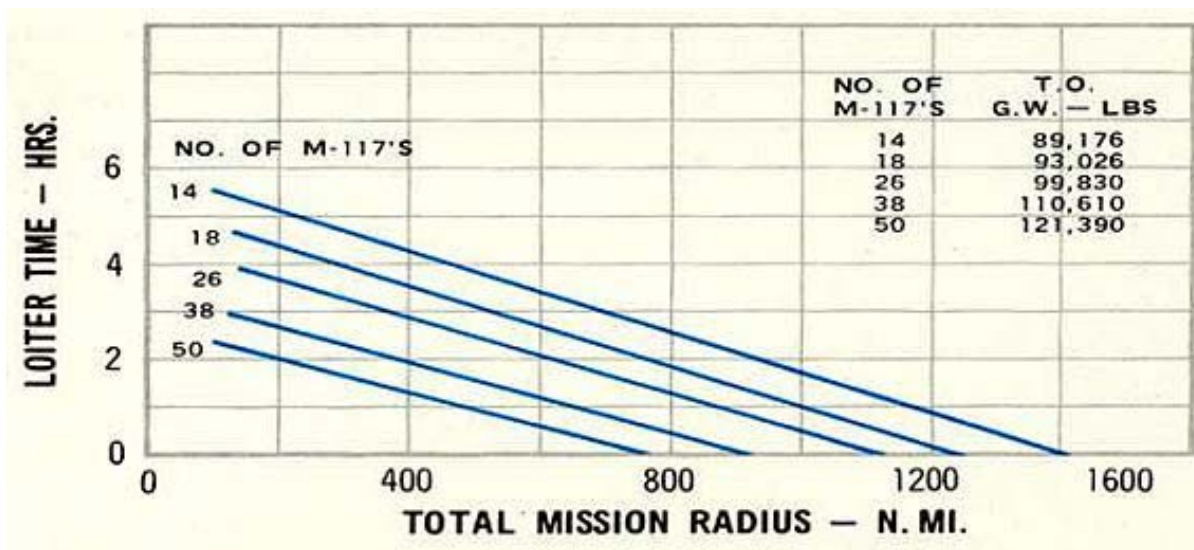

Figure 29: Tradeoff Between Loiter Time and Total Mission Radius [14]

The GD Proposal's configuration is 14 M-117 general purpose bombs. Two are carried internally and six are loaded on each of two pivoting pylons stations (Figure 30). According to Figure 29, an aircraft configured as such has a loiter time of 5.1hours for a total radius mission of 200 N.Mi.

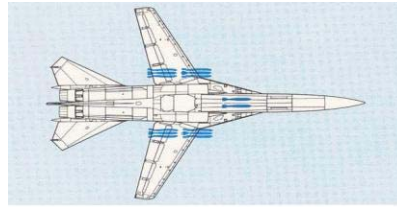

Figure 30: Loiter Configuration [14]

6.2.2.6 Intercept Mission

This mission is explained in section 5.4.4. Cruise at Mach 2.2 is performed to the intercept point where a 5 minute maximum power Mach 2.5 combat fuel allowance is observed. Return to base is accomplished at optimum Mach 2.2 cruise conditions with all missiles aboard (Figure 31).

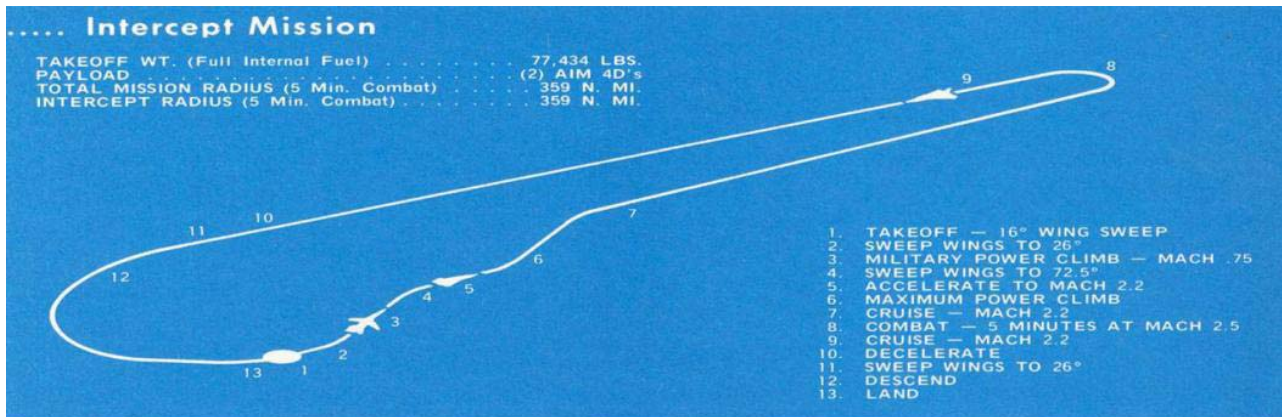

Figure 31: Intercept Mission Profile [14]

The criterion of performance in this kind of mission is the combat time at Mach 2.5 as a function of the total mission radius. This is given on Figure 32 for different numbers of AIM-4/D air-to-air missiles carried by the aircraft.

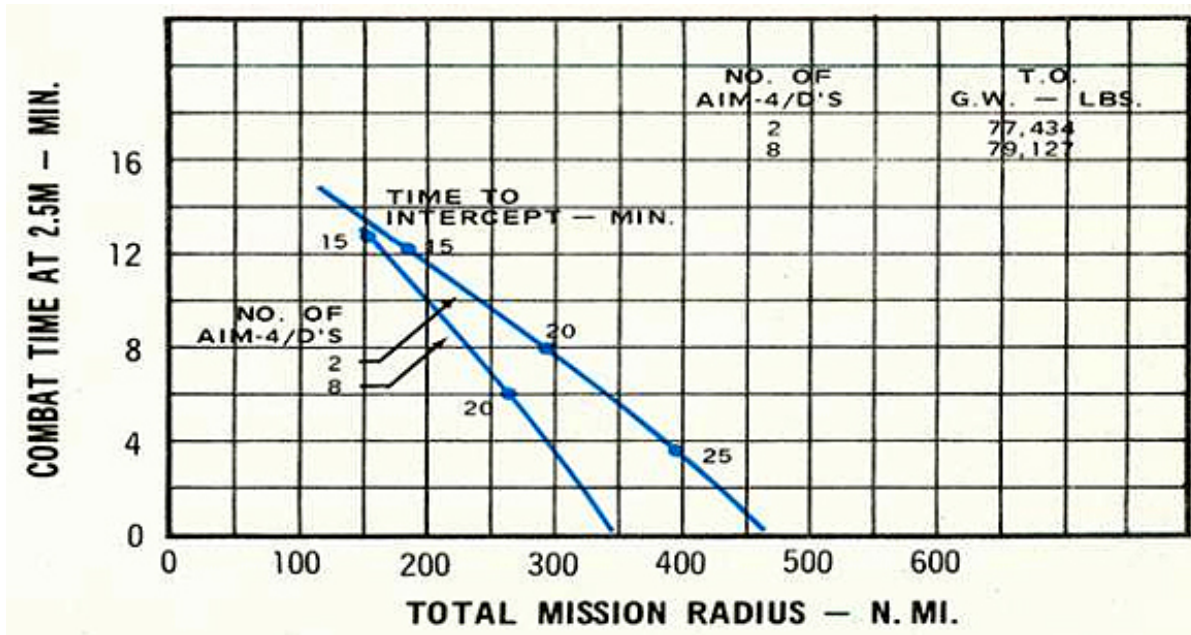

Figure 32: Tradeoff Between Combat Time at Mach 2.5 and Total Mission Radius [14]

In the GD proposal, the total mission radius is 359 nautical miles and the aircraft is configured with 2 AIM-4/D air-to-air missiles mounted in the weapons bay (Figure 33). Figure 32 shows that in these conditions, an aircraft is able to perform a 5 min combat at Mach 2.5.

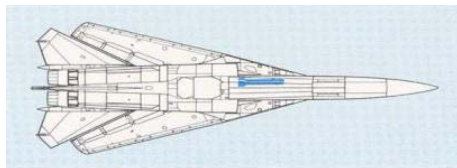

Figure 33: Intercept Configuration [14]

6.2.2.7 Ferry Mission

This mission has been described in section 5.4.5 and is shown by Figure 34.

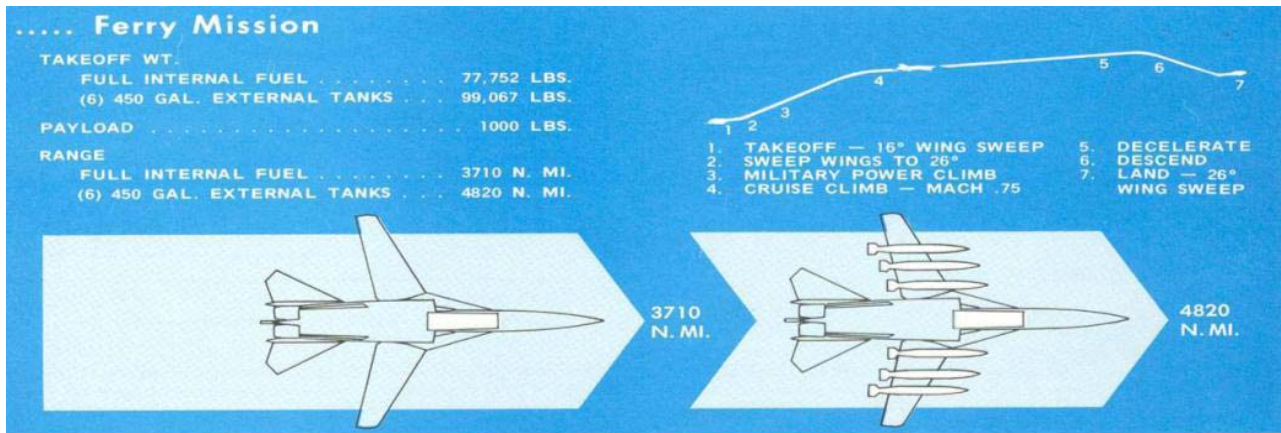

Figure 34: Ferry Mission Profile [14]

It is important to know the range of the aircraft depending on Mach number. This is given by Figure 35 for an aircraft carrying a 1000 lbs ferry kit (fuel tanks in the weapon bay).

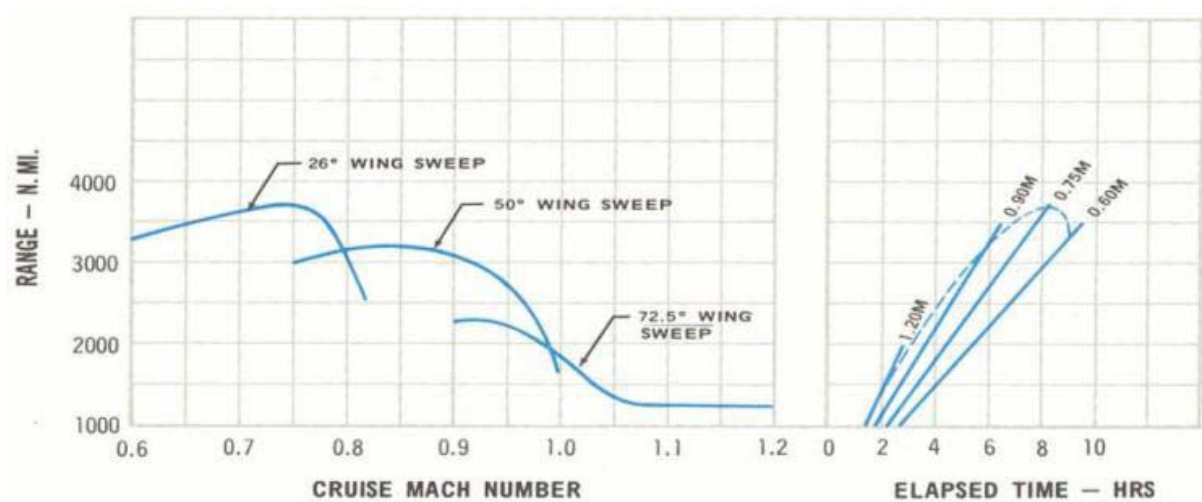

Figure 35: Range as a Function of Cruise Mach Number, Sweepback Angle, and Time [14]

Note a decrease in the range for high speeds and large sweepback angles. It is due to the higher drag resulting from these conditions. The maximum range is obtained for a Mach 0.75 cruise speed and a sweepback angle of 26 degrees. The ferry range is then 3710 nautical

miles. With the addition of six 450 gallon external fuel tanks, ferry range is increased to 4820 nautical miles if the tanks are dropped when empty.

6.3 Description of Major Sub-systems

This section will describe the following major aircraft subsystems: Airframe and Materials, Wings and Sweep Mechanism, Propulsion, Fuel System, Electrical System, Hydraulic and Pneumatic System, Payload Weapons and External Stores, Landing Gear, Cockpit, Avionics, Control System, and Crew Escape Module.

6.3.1 Airframe and Materials

The requirements for the F-111 drove the need for a high-strength structure. The aircraft was constructed using mainly steel and aluminum alloys, with limited use of titanium. The fuselage has a semi-monocoque structure, assembled using large one-piece machined structural members for high strength-to-weight ratios. The F-111 was the first production aircraft to have a variable wing-sweep mechanism, and it will be described further in the next section. The Navy version was designed to have a folding nose radome to accommodate length restrictions associated with carrier operations. It had an overall length of 20.97m (68ft. 9.5in.) and was 19.74m (64ft. 9.2in.) with the radome folded. The slightly longer Air Force version has a total length of 22.40m (73ft. 6in.) with a height of 5.22m (17ft. 1.4in.). Figure 36 below shows the basic internal structure of the F-111.

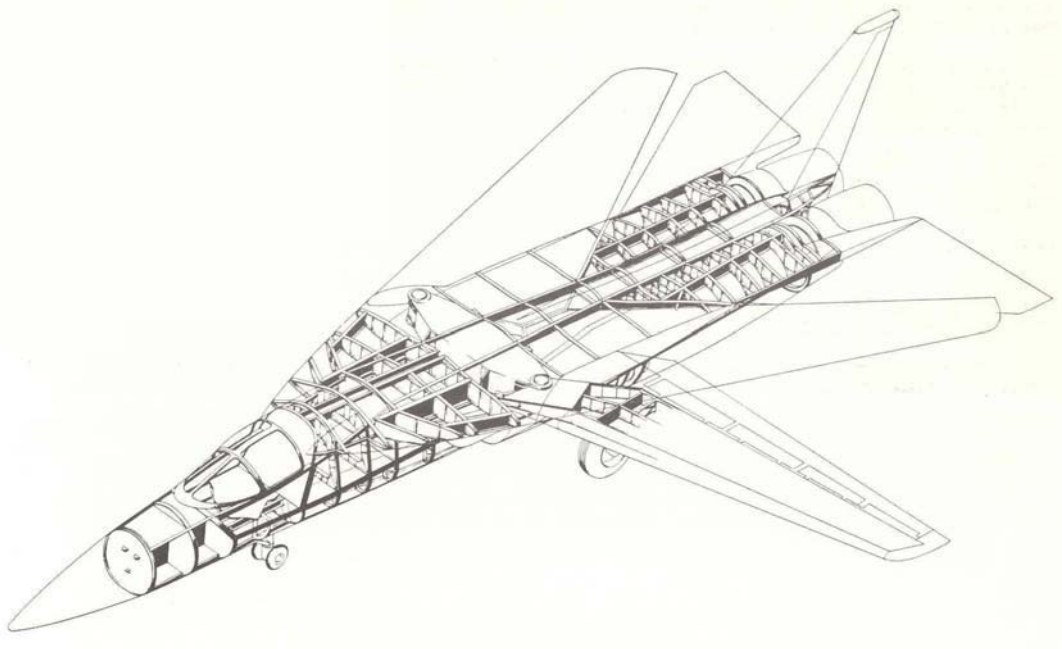

Figure 36: F-111 Structural arrangement [10]

The external panels mainly consisted of bonded honeycomb-sandwich panels. As shown in Figure 37, these panels consist of thin, high-density inner and outer facings bonded to a low-density aluminum honeycomb core. Typical to many aerospace applications, these panels are used to overcome the problem of increasing weight with increasing material thickness.

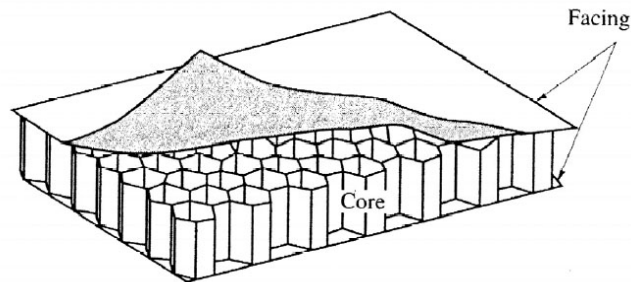

Figure 37: Honeycomb-sandwich panel [15]

By weight, the material use was about one third steel, and two thirds aluminum. Lockheed Martin Tactical Aircraft Systems (which acquired the General Dynamics, Fort Worth division in 1993) identified a list of 13 different materials used in the F-111. This list is presented as Table 11 in the appendix. Of the 13 materials, the most important was D6ac steel, since it was used in the most structure-critical components. General Dynamics classified 15 critical forgings and 11 critical parts (other than forgings), where failure in flight would likely be catastrophic and resulting in loss of aircraft. Of these parts, all but two were made using D6ac steel. In particular, much of the wing pivot fitting, wing pivot support assembly, and wing carry-through box was made from D6ac steel. D6ac is an ultra-high-strength steel with medium carbon content. However, due to manufacturing defects, the material exhibits a large variation in fracture toughness, with the lower limit being unacceptably low for the F-111. This was the cause of the initial failures of the F-111, and will be described in further detail in Section 10.2.

The remaining two critical parts were the upper and lower wing surfaces, and were manufactured using 2024-T851 aluminum. The high operating speed of the F-111 meant that the wings would experience correspondingly high operating temperatures, where the strength of the aluminum alloys would be reduced. Among the aluminum alloys used in the F-111, 2024-T851 aluminum exhibited lower strength at room temperature than the 7xxx-series alloys, but outperformed them at higher temperatures, so it was eventually selected.

6.3.2 Wings and Sweep mechanism

The F-111 has cantilever shoulder wings that have a sweep angle range of 16° (spread) to 72.5° (fully swept). The wings have a five-spar structure, with stressed and sculptured wing skin panels made from 2024-T851 aluminum. Each panel had a honeycomb-sandwich structure, and was made from a single piece of metal from the root to the tip, and from the leading to trailing edges.

Leading-edge slats and double-slotted trailing-edge flaps spanned the full wing, allowing the wing area and camber to change for loiter and take-off. For loiter, the double-slotted flaps extend with a 10° deflection, while the slats extend and droop to 31° , thereby increasing the camber and wing area for optimal loiter time. For take-off, both slats and flaps deflect to a maximum of 40° for maximum lift. The wings also have air-brake/lift dumpers that operate as spoilers for lateral control at low speeds.

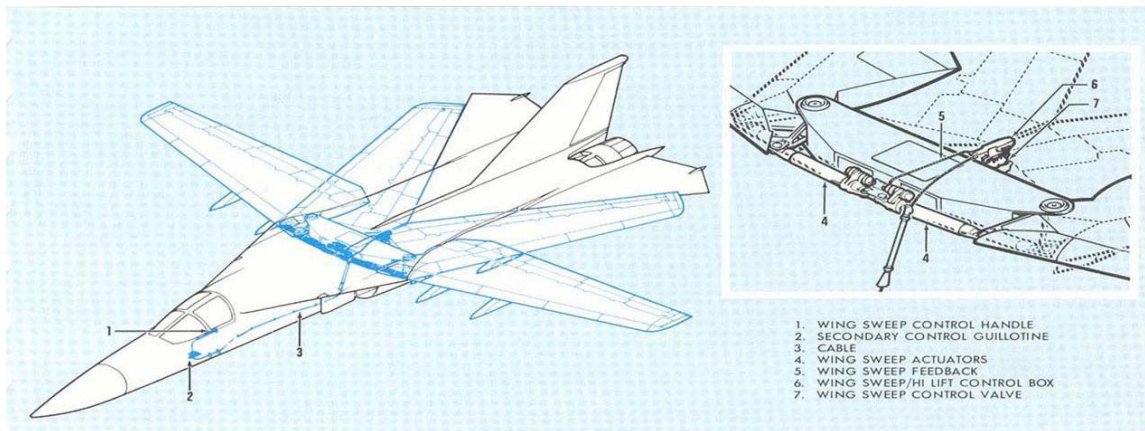

Figure 38: F-111 wings and sweep mechanism [12]

As shown in Figure 38, the sweep mechanism has a single pin pivot arrangement. Dual loading paths were provided to reduce stress levels. The wing carry-through box was assembled as a single unit and was designed such that it may be easily removed and mated to the fuselage to facilitate maintenance activities. It also doubles-up as part of the forward fuselage fuel tank. A dry-film lubricant was used to lubricate the bearing surfaces, and double-seals protect these surfaces from contamination by foreign particles. Also, a special grease compound protected the joint from moisture.

The wings are swept and spread via a hydraulic mechanical actuation system as shown in Figure 39. The system was actuated via a manual control from the cockpit. The two acme-threaded hydraulic actuators are interconnected to ensure symmetrical wing position. Each actuator is powered by a hydraulic motor, and is able to operate under 4g load conditions. Locking is achieved by the use of three spring-positioned, locking rollers, with “no back” rollers that lock when hydraulic pressure is removed. The two actuators are powered by separate hydraulic systems so that in the event of failure of either system, the remaining system can still provide wing actuation through the mechanical interconnect. The hydraulic system is described further in Section 6.3.6.

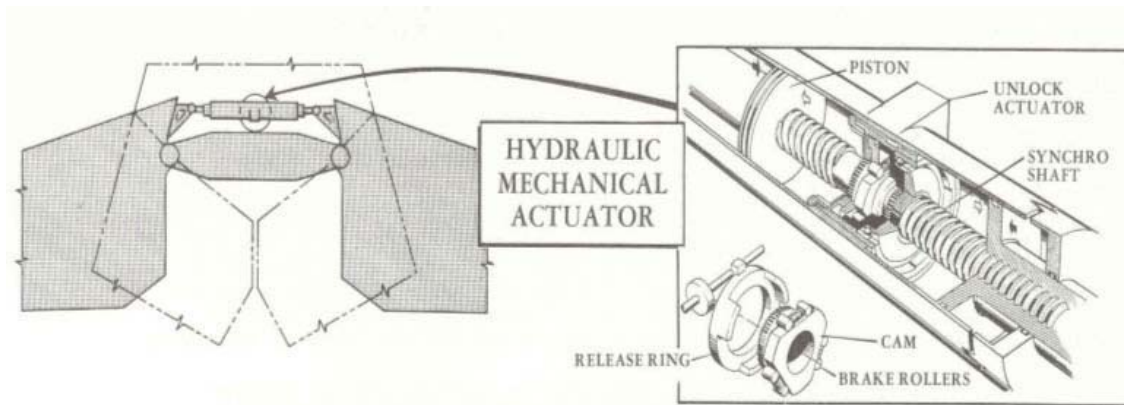

Figure 39: F-111 wing sweep actuation system [10]

6.3.3 Propulsion

6.3.3.1 Engine

Two Pratt and Whitney TF30 afterburning turbofan engines powered the F-111. The TF30 was the first afterburning turbofan ever developed, and was a key technological advance that made the development of the F-111 possible. Before the F-111, turbofans had been built, but only for subsonic bombers and transports. By combining afterburner and turbofan technology, a higher maximum thrust and superior fuel economy was achieved.

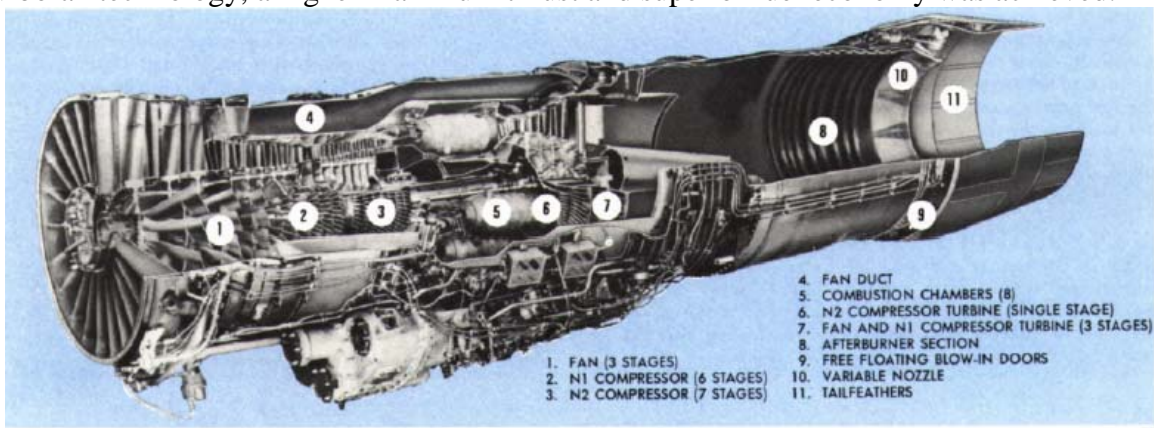

Figure 40: Pratt and Whitney TF30-P-3 engine [12]

Figure 40 shows a cutaway diagram of the TF30-P-3 afterburning turbofan. The 3 fan stages provide initial pressurization of the air entering the engine. The outer portion of fan air is pumped through the fan duct that surrounds the basic engine core, and subsequently joins the airflow from the turbine discharge. The inner portion of fan air goes through the basic engine, and is compressed through six stages of low pressure compression (N1), followed by 7 stages of high pressure compression (N2). This air is then diffused into the can-annular

combustion chamber containing 8 combustion cans. Fuel is metered by a conventional hydro-mechanical control and supplied via four dual orifice fuel nozzles at the forward end of each combustion chamber. Ignition occurs via igniter plugs located in two of the combustion chambers. Following ignition, combustion is self-sustaining. The turbines are driven by the heated fuel-air mixture entering the turbine section. The high pressure compressor turbine is single-stage, while the low pressure compressor turbine has three-stages.

Leaving the turbine, the engine air joins the outer fan air in the afterburner section. Here, an afterburner fuel control injects fuel at several stages, providing thrust ranging from minimum to maximum afterburner. Aft of the afterburner section is a variable nozzle that is hydro-mechanically controlled. Six free floating blow-in doors open and close according to pressure differences between the air inside and outside. When open, outside air enters and supplements the engine exhaust to increase engine thrust. The free-floating tail feathers similarly vary in cross-section according to differential pressure.

Initially, the F-111 used the TF30-P-1 version of the engine, but it was later replaced by the TF30-P-3 in the production F-111A. Compared to the P-1, the P-3 had a redesigned stator inlet, compressor spools with changed blade angles, a sixth stage bleed to improve stall tolerance, a new afterburner fuel system, and a modified nozzle. Both versions have a static thrust of 10,700 lb st (47.6 kN) and 18,500 lb st (82.3kN) with afterburning, but the TF30-P-3 has lower supersonic specific fuel consumption at sea level. Both versions also have a specific fuel consumption of 2.50 lb/h/lb st. The air-intake system was a Hamilton Standard (now Hamilton Sundstrand) hydro-mechanical system with movable shock-cone.

Subsequent versions of the TF30 were used in variants and upgrades of the F-111, as well as other aircraft, such as the Vought A-7A and the F-14. A summary of the different TF30 versions and aircraft that used them is provided in Table 4 below. Thrust and specific fuel consumption is provided where available.

Table 4: List of TF30 versions [1, 16]

Engine	Aircraft	Thrust, lb st (kg st)	SFC, lb/h/lb st
TF30-P-1	F-111 (pre-production)	18,500 (8,390)	2.50
TF30-P-3	F-111A	18,500 (8,390)	2.50
TF30-P-12	F-111B	20,250 (9,185)	3.04
TF30-P-7	FB-111	20,350 (9,231)	3.013
TF30-P-9	F-111D	19,600 (8,891)	2.61
TF30-P-412	F-14	20,900 (9,480)	--
TF30-P-100	F-111F	25,100 (11,340)	2.45
TF30-P-6 (non A/B)	Vought A-7A	11,350 (5,150)	0.620
TF30-P-8 (non A/B)	Vought A-7B Corsair II	12,200 (5,534)	0.630
TF30-P-408 (non A/B)	--	13,400 (6,080)	0.64

Further technical details of the TF30 engine as presented in *Jane's All The World's Aircraft, 1976-77* may be found in the appendix.



6.3.3.2 Engine-inlet

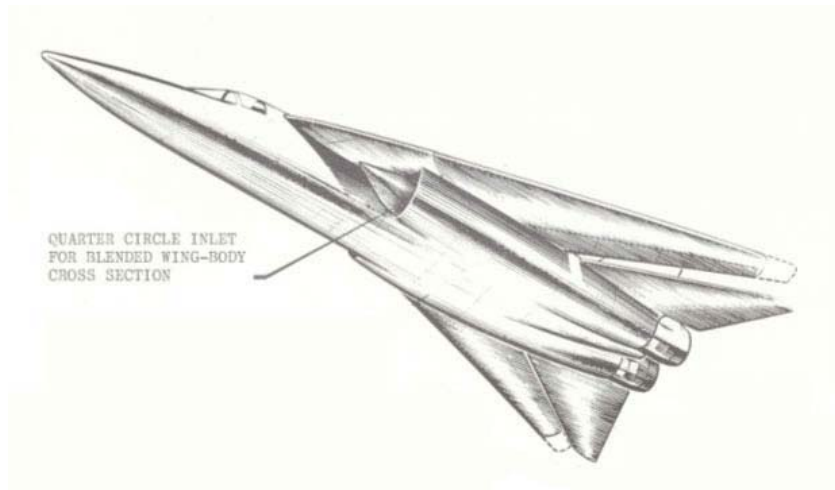

Figure 41: Location of F-111 engine-inlet [10]

The original engine-inlet was a quarter-circle design with a high-speed bypass system coupled with a movable inlet spike. As shown in Figure 41, the inlet was located aft of the leading edge of the wing and next to the fuselage, and a splitter plate was designed to direct turbulent airflow away from the inlet. The inlet spike varied the geometry of the air inlet to control the inlet shock wave pattern. However, the turbulence created by the airflow over the wing and fuselage was not properly anticipated during the design of the inlet. Early F-111s had major compatibility problems between the engine and the engine-inlet, and suffered from repeated compressor surges and stalls, particularly at higher speeds and angles of attack. Subsequent modifications by General Dynamics resulted in the Triple Plow I (TP I) inlet design used in all production F-111As.

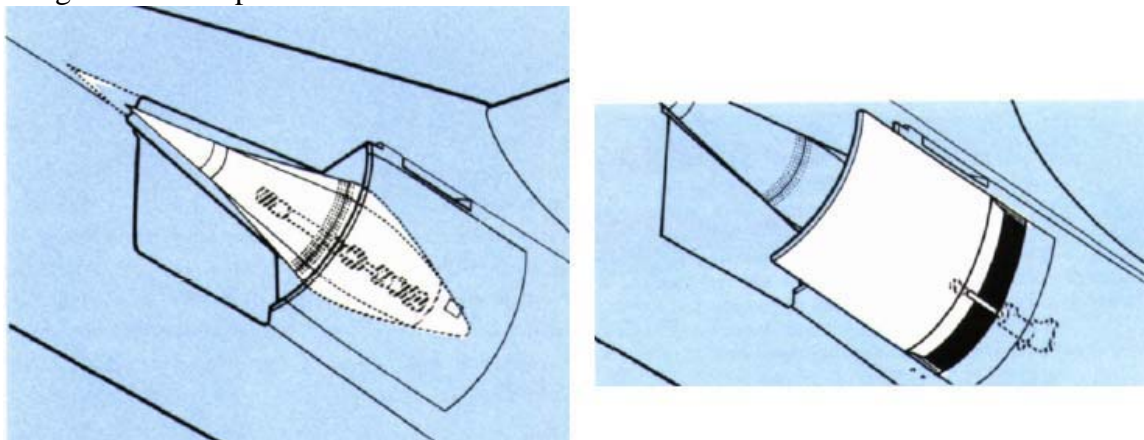

Figure 42: F-111 movable inlet spike (left) and variable cowl (right) [12]

The TP I design incorporated a translating cowl as shown in Figure 42. The translating cowl allows additional air to enter the inlet for better performance during ground operation and low speed flight. Additionally, the splitter plate was curved and extended outwards by 4 inches from the original design. A notched side-plate was also placed within the inlet, accompanied with a thickening of the inlet lip. As a result, the engine stall region was moved to Mach 2 in maneuvering flight and Mach 2.35 in level flight, and was deemed satisfactory, since further changes would require a structural change to the aircraft.

NASA, the Air Force, and General Dynamics pursued further improvement to the inlet to produce the Triple Plow II (TP II) design in late 1967, which moved the stall region beyond Mach 2.4 at high altitudes and angles of attack. The TP I and TP II are shown side by side in Figure 43. The TP II design had three blow-in doors, and the inlets and ducts were enlarged and moved outward (away from fuselage) by about 4 inches. Having no more need for the splitter plate, it was removed. Also, the inlet spike was extended by about 18 inches. Common to both designs, vortex generators were installed in the inlet aft of the translating cowl. These “teethy-looking” features can be seen in Figure 43. The vortex generators were placed in pairs of opposing angles of attack, creating contra-rotating vortices that prevent airflow separation from the duct walls, and cancel their rotational energy before reaching the compressor face. The TP II design was incorporated into the later F-111 models: the F-111D, E, F, Gs as well as the FB-111As.



Figure 43: Triple Plow I (left) and Triple Plow II (right) engine inlets [17]

6.3.4 Fuel System

The F-111 has two fuselage tanks located forward and aft, a vent tank (in vertical stabilizer), as well as two wing tanks (one in each wing). The forward fuselage tank is further divided into bay F-1, bay F-2 and a reservoir tank, while the aft fuselage tank is divided into bay A-1 and bay A-2. Additionally, a total of six 600 gallon external tanks could be carried on the external wing pylons. The maximum internal fuel capacity is 5015.5 gallons, and

maximum external capacity is 3607.4 gallons, giving a total capacity of 8622.9 gallons. Figure 44 below shows the layout of the fuel tanks, fuel receptacles and corresponding capacities of each tank.

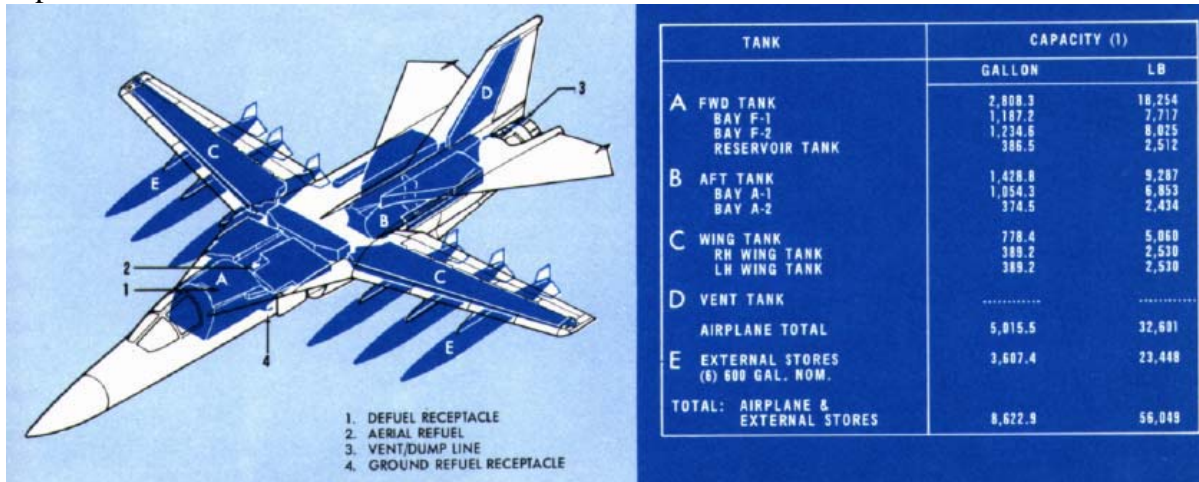

Figure 44: F-111 Fuel System [12]

Fuel is only supplied to the engines from the fuselage tanks, so wing and external fuel is transferred to the fuselage tanks for consumption. Wing tank fuel is transferred by two pumps in each wing, while external tank fuel is transferred by pressurized air. There are four fuel supply modes: FWD, AFT, BOTH and AUTO. In FWD or AFT modes, fuel to both engines is supplied by the forward or aft tanks respectively. In BOTH and AUTO modes, the left engine consumes fuel from the forward tank, while the right engine consumes from the aft tank. Additionally, in the AUTO mode, a gauging system senses excessive imbalances between the forward and aft tanks. If it senses too much fuel in the forward tank, the aft tank pumps are turned off, and both engines consume from the forward tank until balance is restored. On the other hand, if there is too much fuel in the aft tank, excessive fuel is automatically pumped into the forward tank.

A pressure fuelling point is located in the port side of the fuselage, forward of the engine air intake. There is also a gravity fuel filler/in-flight refueling receptacle located aft of the cockpit in the top of the fuselage.

6.3.5 Electrical System

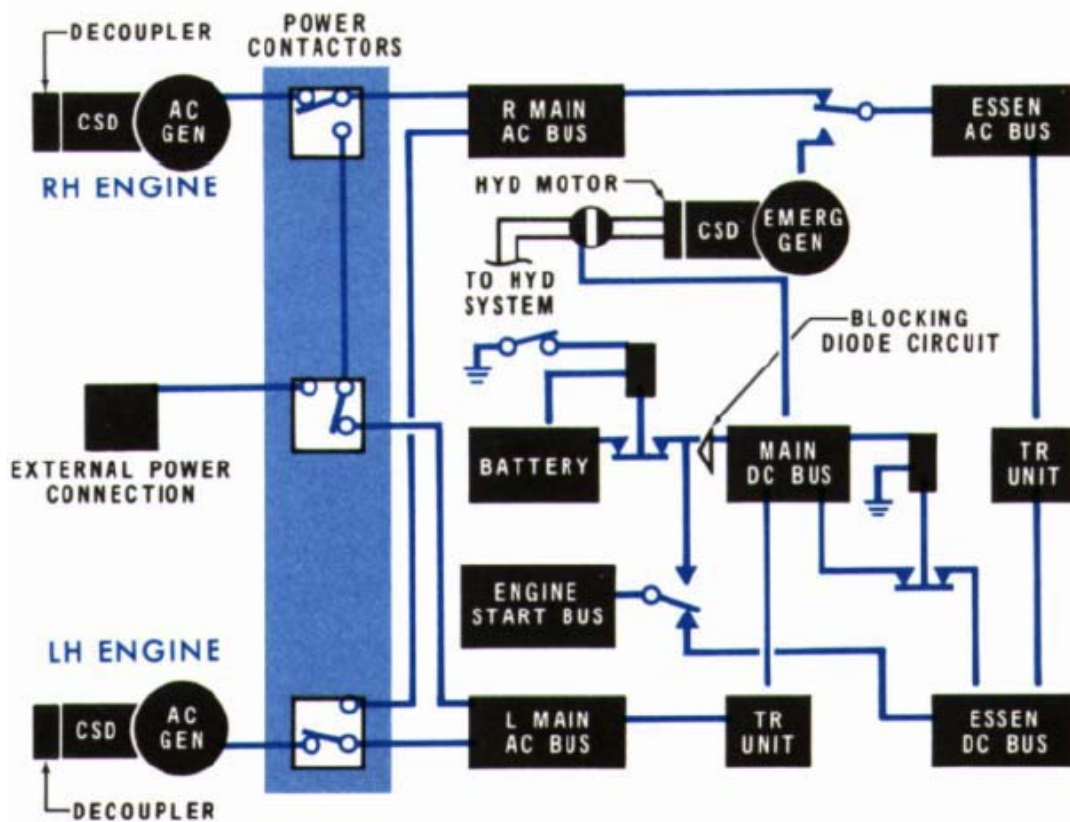

Figure 45: F-111 Electrical System [12]

Figure 45 above is a schematic of the electrical system in the F-111. The electrical system provides 400 cycle, 115/200 volt, 3 phase AC and 28 volt DC power. AC power is supplied by two 60KVA systems. Two oil-cooled generators are driven by engine-powered constant speed transmissions, and can be controlled by the pilot via an on-off switch for each generator. However, in the event of engine shutdown or generator-drive malfunction, the generator will automatically be switched off even when the control switch is on. Under normal operation, the two generators supply separate load buses, but if either generator is switched off, the two buses will be automatically connected. A single generator is sufficient to power the whole aircraft.

DC power is generated from the AC power system by two 28 volt, 150 amp transformer-rectifiers, which are supplied by a separate AC buses. Each transformer-rectifier feeds individual DC buses that are normally connected by a bus tie relay. As with the AC power generators, each DC bus is capable of powering the entire aircraft load, but there are no controls necessary for the DC power system. A nickel-cadmium battery charged by the DC system provides power for starter operation, minimum engine instruments, and minimum cockpit lighting when external power is not available.

In the event of the loss of primary generating systems, an emergency electrical power system provides power to all electrical systems essential for flight, which includes primary flight controls, external lighting and the anti-icing system. The emergency power is supplied by a 10KVA, 400 cycle, 115/200 volt, 3 phase, air-cooled generator driven by a hydraulic motor. When activated, shutoff valves are automatically opened to supply hydraulic power to the motor and cooling air to the generator. The generator is automatically connected to the buses that power the essential flight systems.

6.3.6 Hydraulic and Pneumatic System

Two independent, parallel, 3000 psi hydraulic systems, designated as “primary” and “utility”, provides hydraulic power to the aircraft. Under normal conditions, the two systems concurrently supply power to flight controls and wing sweep; however, either system alone supplies enough power for these functions. The utility system also powers the landing gear, tail bumper, nose wheel steering, wheel brakes, speed brakes, flaps, air inlet control, aerial refueling, weapon trapeze, weapon bay doors, weapon bay gun, and emergency electrical generator. Figure 46 below is a schematic of the hydraulic system.

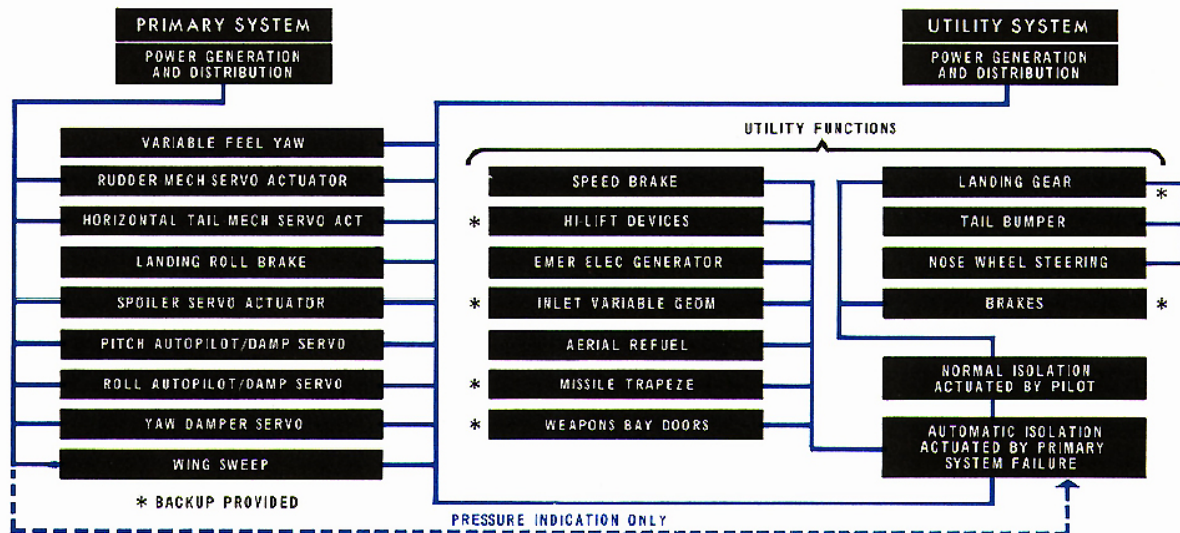

Figure 46: F-111 Hydraulic System [12]

Each system is supplied by two engine-driven, variable-delivery pumps. For redundancy considerations, one pump in each system is driven by the right engine, and the other is driven by the left engine. Each system has a piston-type reservoir that provides fluid storage, and is pressurized by stored nitrogen. The reservoirs are controlled by pressure regulators and relief valves. A pressure transmitter in each system also provides pressure information to the cockpit, and a caution light for each pump comes on in the event of low pressure. Also, in the event of hydraulic rupture or loss of primary system pressure, an automatic isolation valve prevents fluid loss to the utility system flight controls, wing sweep motors, and reservoir.

6.3.7 Payload, Weapons and External Stores

The Air Force version, the F-111A, has no fixed weapons or external stores configurations and instead utilizes a “plug and play” concept of inserting different weapons packages for the specific mission. It has a versatile weapons capability, and can carry an array of air-to-surface, air-to-ground, conventional and nuclear weapons, as well external fuel tanks. The internal weapons bay can house an M61 multi barrel 20mm gatling gun and one 750 lb class bomb or missile, or two bombs or missiles. External stores can be carried on four hardpoints under each wing. Of these four hardpoints, the two inboard pylons pivot as the wings sweep to remain parallel to the fuselage. The two outboard pylons are non-pivoting and are jettisonable prior to sweepback.

..... Weapons

		UP TO 72.5° WING SWEEP						UP TO 55° WING SWEEP						26° WING SWEEP										
		3	4	WB	5	6	TOT	3	4	WB	5	6	TOT	1	2	3	4	WB	5	6	7	8	TOT	
MISSILES	AIM-9B	2	1	2	1	2	8	2	1	2	1	2	8			2	1	2	1	2				8
	AGM-12B	1	1	2	1	1	6	1	1	2	1	1	6	1	1	1	2	1	1	1	1			8
	SHRIKE	1	1		1	1	4	1	1		1	1	4	1	1	1	1	1	1	1				4
ROCKET LAUNCHERS	LAU-3A/A	3	1		1	3	8	3	3		3	3	12	3	3	3	3		3	3	3	3	3	24
	LAU-10/A	3	1		1	3	8	3	3		3	3	12	3	3	3	3		3	3	3	3	3	24
	LAU-18/A	3	1		1	3	8	3	3		3	3	12	3	3	3	3		3	3	3	3	3	24
GUNS	SUU-16A	1	1		1	1	4	1	1		1	1	4			1	1		1	1			4	
	GUN MODULE			1			1			1			1					1					1	
NUCLEAR WEAPONS	MK-43	1	1	1	1	1	5	1	1	1	1	1	5	1	1	1	1	1	1	1	1	1	5	
	MK-57	1	1	2	1	1	6	1	1	2	1	1	6	1	1	2	1	1	1	1	1	1	6	
	TX-61	1	1	2	1	1	6	1	1	2	1	1	6	1	1	2	1	1	1	1	1	1	6	
CONVENTIONAL BOMBS	M-117	6	2	2	2	6	18	6	6	2	6	6	26	6	6	6	6	2	6	6	6	6	6	50
	MC-1	6	2	2	2	6	18	6	6	2	6	6	26	6	6	6	6	2	6	6	6	6	6	50
	BLU-1/B	2	1	1	1	2	7	2	2	1	2	2	9	2	2	2	2	1	2	2	2	2	2	17
	MLU-10/B	3	3	2	3	3	14	3	3	2	3	3	14	3	3	3	3	2	3	3	3	3	3	26
	BLU-14/B	3	3	2	3	3	14	3	3	2	3	3	14	3	3	3	3	2	3	3	3	3	3	26
DISPENSERS	CBU-1A/A													3	3							3	3	12
	CBU-2A/A													3	3							3	3	12
	CBU-3/A													3	3							3	3	12
	SUU-13/A	3	3		3	3	12	3	3		3	3	12	3	3	3	3		3	3	3	3	3	24
	CBU-6/A													3	3							3	3	12
TRAINING	A/B 45Y-1	1	1		1	1	4	1	1		1	1	4	1	1	1	1		1	1	1	1	1	8
	TMU-28E	1	1		1	1	4	1	1		1	1	4	1	1	1	1		1	1	1	1	1	8
FUEL TANKS	450 GAL	1	1		1	1	4	1	1		1	1	4	1	1	1	1		1	1	1	1	6	

Figure 47: F-111A Weapons configuration chart [14]

6.3.8 Landing Gear

The landing gear is a hydraulically actuated forward retracting tri-cycle type. The main leg consists of a single wheel mounted on either side of a common trunnion, while the nose unit has twin wheels. A photograph of the main gear is shown in Figure 48.





Figure 48: F-111 Main Landing Gear [18]

During retraction, hydraulic actuators cause the nose unit to retract forward. For the main gear, the legs pivot downwards and aft as the wheels retract forward and up. The wheels then stow side-by-side in the fuselage between the engine air intake ducts.

The braking system utilizes disc brakes equipped with an anti-skid system. Dual hydraulic brake circuits provide the redundancy necessary to ensure safe operation. In addition, two pneumatically charged hydraulic accumulators provide hydraulic pressure for emergency braking or parking. Actuation of the auxiliary brake control handle applies accumulator pressure to brake for parking.

In order to minimize the danger of a failed downlock, the gear linkages are designed such that landing loads tend to extend the drag strut to the locked down position. Large, low-pressure tires are used to ensure operational capability from semi-prepared airfields.

The plane also has a hydraulically operated tail bumper that extends and retracts with the landing gear. This prevents the control surfaces, engines and aft portions of the aircraft from being damaged in the event that the tail accidentally contacts the ground. It also provides some protection against over-rotation during take-off and landing.

6.3.9 Cockpit and Avionics

6.3.9.1 Cockpit

The crew compartment of the F-111 was a pressurized and temperature controlled environment. This provided a comfortable workspace for the crewmembers. The whole organization of the cockpit has been greatly influenced by the choice of side-by-side seating. It was designed to promote the “team concept”, allowing a better communication between the Aircraft Commander and the Pilot. This design choice also avoided the need of a separate airplane designed for crew training.

The compact arrangement of instruments minimized the need for duplication. The Aircraft Commander sat on the left in the “primary flight station” equipped with all the instruments necessary for flight control. The Weapons Systems Officer (WSO) sat on the right in the “primary avionics systems control station” equipped with weapons delivery

controls, and also with instruments necessary to perform pilot functions. It resulted in two self-sufficient stations but offered a sufficient flexibility in the task distribution between the crewmembers.

Nuclear shielding curtains were included in the cockpit over the crew stations to reflect the flash if the F-111 was ever used for a nuclear delivery mission. Another interesting feature of the cockpit was individual ladders stored under each pilot station reducing ground support necessary for operations.

Figure 49 shows the arrangement of instruments in F-111A. The two striped handles on the center console are the ejection handles. The hood on the right is the WSO's attack radar display [12].

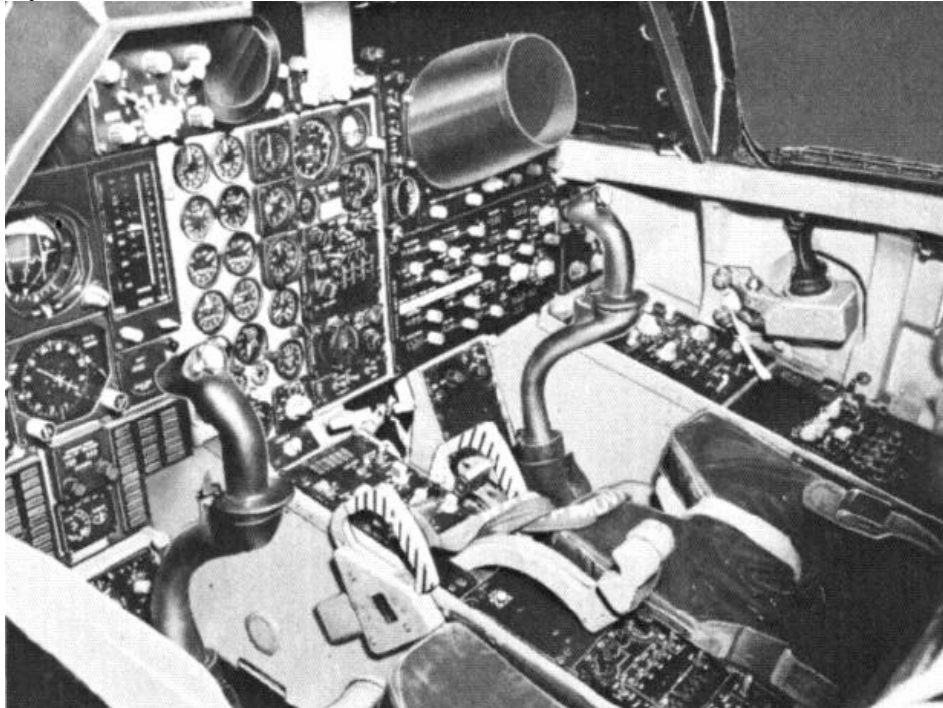

Figure 49: F-111 cockpit [12]

The bottom of the optical sight can be seen in the upper-left corner of Figure 49. The optical sight was part of the navigation and attack system and was an early head-up display. It was located in front of the pilot's left seat station only. The optical sight is shown below in Figure 50. The left side shows the display unit. The right side shows the one of the displays shown to the pilot. The pilot could select several displays of varying information.

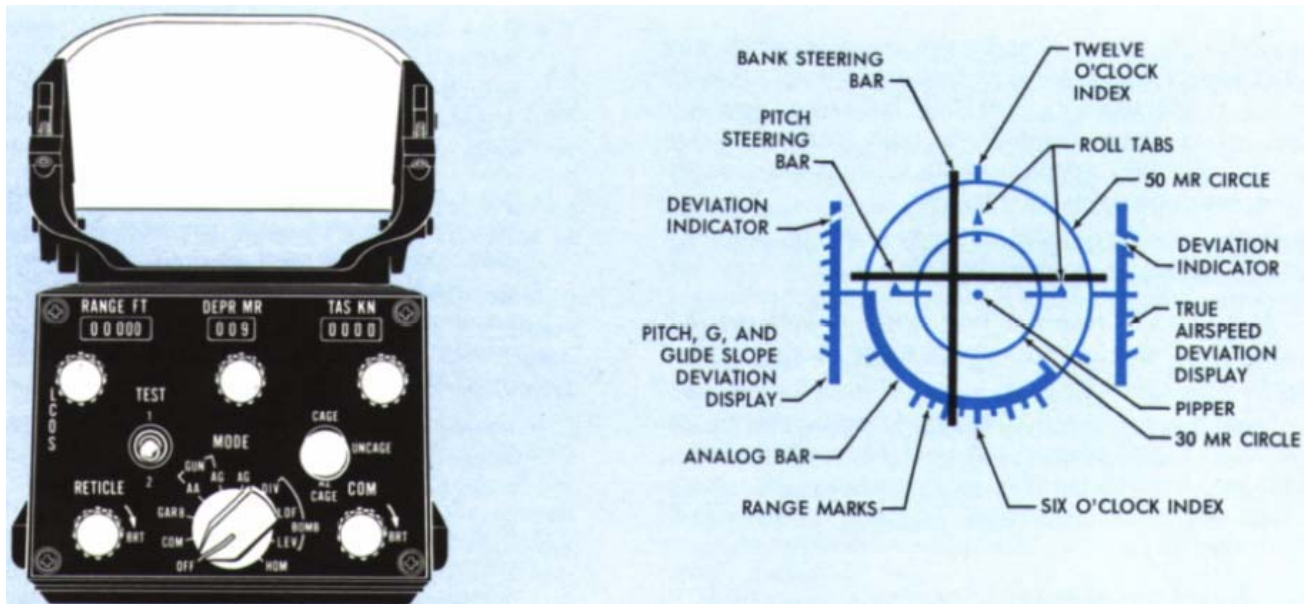

Figure 50: Optical sight (Heads-up display) [12]

One flaw of the design of the F-111 cockpit was in the sweep control handle. The wing sweep control was located on the left side of the left-seat pilot, just under the canopy. The control was shaped like a trombone handle or a pistol grip. There were three problems with the design of the handle: its location, shape, and direction for controlling sweep. It was important for the pilot to always know where the wings were, and at least one crash was caused by the pilots sweeping the wings the wrong way [17]. According to an early F-111A flight manual (reference 23), the sweep control was slid forward to sweep the wings back, and aft to sweep the wings forward. This seemingly reverse logic of the designers was based on airspeed. Pushing the controller forward meant the airplane would go faster when the wings swept back, and the designers thought that would be the best correlation for the pilot. The pilots came back to the designers during testing and said that it made no sense, and the controller direction was switched so that pulling it back swept the wings back instead of forward [46]. The next two problems were never fixed. One was that the shape and motion of the control had nothing to do with the shape and movement of the wings. If the control had been shaped like a wing and rotated, then the pilot would be able to tell by feel where the wings were. The final problem was that the control was difficult for the WSO to reach. If

the pilot were killed, the WSO would have had no chance at flying the airplane and reaching the control around the pilot's slumped body. This was a concern for WSO's in the F-111 [46].

6.3.9.2 Avionics

The avionics system provided navigation, terrain-following, air and ground attack capability and management, threat detection, and automatic flight controls. The avionics package was called Mk I Avionics. Later variants of the F-111 carried Mk II and MK IIB avionics, which will not be discussed in detail here. Most aircraft components in or related to the avionics package were listed in the table below:

Table 5: Mk I Avionics Components and Related Components and Manufacturers [1]

Component	Manufacturer
Terrain Following Radar (Air Force only)	Texas Instruments
Doppler Radar (Navy only)	Hughes
Attack Radars (Air Force only)	General Electric
Flight Control Systems	
Navigation and attack system	Litton Industries
Inertial Reference Unit	
Astrocompass	
Air Data Computers	Bendix Corp, Navigation and Control
Low-Alt radar altimeter	Honeywell
Radar homing and warning system	Textron
Electrical Generating Systems	Westinghouse Electric Corp
Mk II/IIB Avionics	Autonetics Division of North American

6.3.9.3 Terrain Following Radar

The terrain-following radar (TFR) was the most significant component of the avionics system providing one of the most important and unique capabilities of the F-111. TFR allowed the F-111 to fly high speed at a constant altitude above varying terrain. Typical altitudes in use were in the 200-1000 ft range, with higher altitudes used in steep, mountainous terrain [20]. By flying in the nap of the earth the F-111 could penetrate deep into enemy territory by a combination of staying below the radar horizon and hiding behind terrain features. TFR allowed the F-111 to perform its mission day or night and in all weather conditions except heavy rain.

In terrain following flight, the TFR constantly monitored the terrain in front of, and to the sides of the aircraft. The TFR's analog computers constantly recalculated which object in front of the aircraft to use to calculate a trajectory. When approaching an obstacle, the TFR commanded the airplane to pull-up at the minimum distance calculated. The computers shaped the flight path so that the airplane was flying level again as it crested the peak,



keeping altitude and thus detectability to a minimum. The TFR could be set for a soft, medium, or hard ride depending on how tight the pilot wanted to hug the terrain. Most pilots flew with a medium setting. The TFR also could command horizontal flight to fly around tall and skinny obstacles such as communications towers. The system monitored obstacles to the left and right of the airplane's path for when the pilot changed course and to be able to accurately measure the height above ground while in a bank. A center mounted cockpit display showed a side view of the topography directly in front and the calculated path planned by the computers [21].

The TFR was relied on to safely guide the aircraft at night and through clouds, where the crew could not monitor the system and detect faults. For redundancy, the system had two independent systems. The active system performed self-checks every 0.7 seconds, and switched to the other system if a fault was detected. If this failed the system goes into its failsafe mode in which it commands a 2-g pull-up and warns the crew of a malfunction via a warning light [21]. Each of the two systems had a scanner. In normal operations, one scanner scanned vertically along the flight path for vertical path planning. The other scanner scanned horizontally for steerage information with a 30 degree azimuth range [23]. If the primary vertical scanner failed, the secondary scanner would begin to scan vertically [23].

The TFR could be operated in manual or automatic mode. In manual mode, the TFR displayed terrain information to the pilot. In automatic mode, the TFR displayed this information and flew the aircraft [21]. As mentioned above, pilots could select a soft, medium, or hard ride. This determined how sharp the aircraft would pull-up or down in following the terrain, which in-turn, determined the g-load experienced by the pilots. A hard ride limited the g-load to +3.0 and 0 absolute and was uncomfortable for the crew [23]. The preferred medium ride produced typical g-loads of $\frac{3}{4}$ to $1\frac{1}{2}$ [22]. The altitude setting for TFR flight could be dialed in to any height from 1,000 to 200 ft AGL. Switching to automatic TFR flight from a higher altitude put the aircraft into a steep dive and then pulled out of the just at the dialed in TFR setting [21].

The system was all-weather capable, and could fly day or night. Rain and other forms of precipitation could interfere with radar operation and would result in the fail-safe mode if the TFR cannot distinguish the ground from the rain [23]. If the system got a bad signal due to a radar or electrical problem the aircraft automatically climbs [1].

6.3.9.4 Navigation and Attack System

The navigation and attack system consisted of inertial measurement units and an analog computer/ display unit. The inertial measurement unit gyros were located on a stabilized platform in the nose of the aircraft [12]. The navigational computer received inertial data from the gyros. The navigational computer computed and displayed latitude and longitude, ground speed, ground track, wind speed, wind direction, stabilized magnetic heading, pitch and roll attitude, and steerage information to a target or waypoint. The computer stored target information, and up to three alternate target destinations. It sent ground track steerage signals to the autopilot. Inertial measured position could be updated

via a fix taken by the attack radar [23]. The computer worked with the attack radar for bombing calculations and weapons delivery. Several pilot-selectable weapons delivery modes were available for various types of weapons [23]. The radar bombing system was day or night all weather capable [24]. The navigation and attack system could bomb a target offset from a radar-visible feature [23]. This feature was used in South East Asia for radar beacon offset bombing. The attack radar provided ground target identification and air-to-air search and range tracking. In air mode, the attack radar had an 85% probability of detecting a one square meter target at 15 nautical miles [12]. The system scans ± 45 degrees in azimuth and ± 30 degrees in elevation, and will lock on a target within 10 nautical miles [12]. The attack radar could also be used to navigate around and between thunderstorms [23]. The navigation and attack system had continuous in-flight monitoring. Sensed errors were displayed to the pilot via warning lights. If there was an error in the inertial measurement unit, the navigational computer used the last stored wind speed, air data, and backup compass measurements to calculate navigational information [23].

6.3.10 Stability and Control

6.3.10.1 Pilot Controls and Control Surfaces (Primary Flight Controls)

Pilot controls in the F-111 were the conventional center-stick and rudder pedal arrangement. Sticks and pedals in the pilot and co-pilot seats were the same and perform the same function. The stick gave lateral (roll) and longitudinal (pitch) command. The pedals gave directional (yaw) command. The stick had low-friction break-out forces for better flying qualities [23]. Pilot controls were mechanically linked to control surface servo actuators [23]. Dual hydraulics moved control surfaces and provide redundancy (see Section 6.3.6 on hydraulics). The electrical and hydraulic systems provide emergency backup power to the control system.

There were no ailerons on the F-111. Flaps and slats increased lift for take-off, landing, and low-speed flight. Wing spoilers were used for lateral controls at low speeds [23]. Horizontal stabilizers moved independently for lateral control and collectively for longitudinal control [23]. The horizontal tail surfaces were connected to the airframe by a pivot and move as a whole. The single vertical tail has an independently movable rudder [23].

6.3.10.2 Flight Control System (Automatic Flight Controls)

The flight control system provides autopilot modes and stability and command augmentation. Autopilot includes heading, altitude, and mach number hold. The autopilot could receive signals from the TFR to flying in terrain-following flight. Stability augmentation was provided in all three axes. Command augmentation was provided in the pitch and roll axes [23]. Stability augmentation gained through roll, pitch, and yaw damping which were independently selectable [23].

6.3.10.3 Longitudinal Control

Longitudinal control came from a direct mechanical linkage from the control stick to horizontal tail surface servo actuators [23]. Purely fore-aft movement of the stick causes the tail surfaces to pivot symmetrically [23]. An artificial force-feel spring gives the pilot 10.8 lbs of forces per inch of longitudinal displacement [23].

6.3.10.4 Lateral Control

Lateral Control came from a direct mechanical linkage to horizontal tail servo actuators and an electrical linkage to spoilers [23]. Lateral movement of the stick caused the horizontal tail surfaces to pivot asymmetrically and the spoilers to actuate appropriately. Spoilers work by causing roll by reducing (spoiling) the lift on one wing, where more conventional ailerons cause roll by increasing the lift on one wing. Spoilers prevent roll-reversal problems caused by ailerons. Spoiler authority (the amount the spoiler contributed to roll) was at a maximum with the wings forward, allowing the spoilers to deflect up to 45 degrees. With greater aft wing-sweep, less spoiler deflection was allowed, down to zero degrees deflection at 45 degrees of sweep. Spoiler authority was also scheduled out as wing sweep increases from a maximum deflection of 45 degrees to zero. At wing sweep angles aft of 45 degrees (where 16 degrees was fully unswept, and 72.5 degrees was fully swept), spoiler command was zeroed so that they were not used [23]. For added safety with wings aft of 47 degrees of wing sweep, hydraulic power was cut off to the spoilers. If a spoiler accidentally deployed, the induced roll caused the pilot to input lateral stick to roll the other way causing both spoilers to be up, which causes a spoiler monitor to cut off hydraulic power to both spoilers causing them to go flat. There was a spoiler monitor reset button for this situation. There was a spoiler authority schedule based on wing sweep.

Differential tail surfaces were effective at all sweep angles. For a coupled lateral and longitudinal command the differential lateral command and the collective longitudinal command were summed mechanically [23]. “Full” lateral stick to the force detent gives full spoiler deflection and $\frac{1}{4}$ differential stabilizer [23]. For extra roll authority in emergencies, stick can be forced past detent to the stops [23].

The F-111 lateral control scheme was similar to that of other aircraft. Delta wing airplanes using ailerons on the trailing edge of the wing were similar to an F-111 using tail surfaces with its wings swept. The F-4 used spoilers and ailerons. The F-18 uses differential tail in addition to ailerons.

6.3.10.5 Directional Control

Directional control comes from a direct mechanical linkage from the pedals to the rudder servo actuators [23]. This was a conventional system. Yaw damping was mechanically added in series.

6.3.10.6 Stability and Command Augmentation

Longitudinal command augmentation maintains constant stick force per g-load [23]. At higher speed, less surface deflection results from the same stick command. The control

system compares commanded and measured pitch rate and g-load and mechanically reduces or increases surface deflection to match the command [23]. An estimated stick force per g-load chart was below:

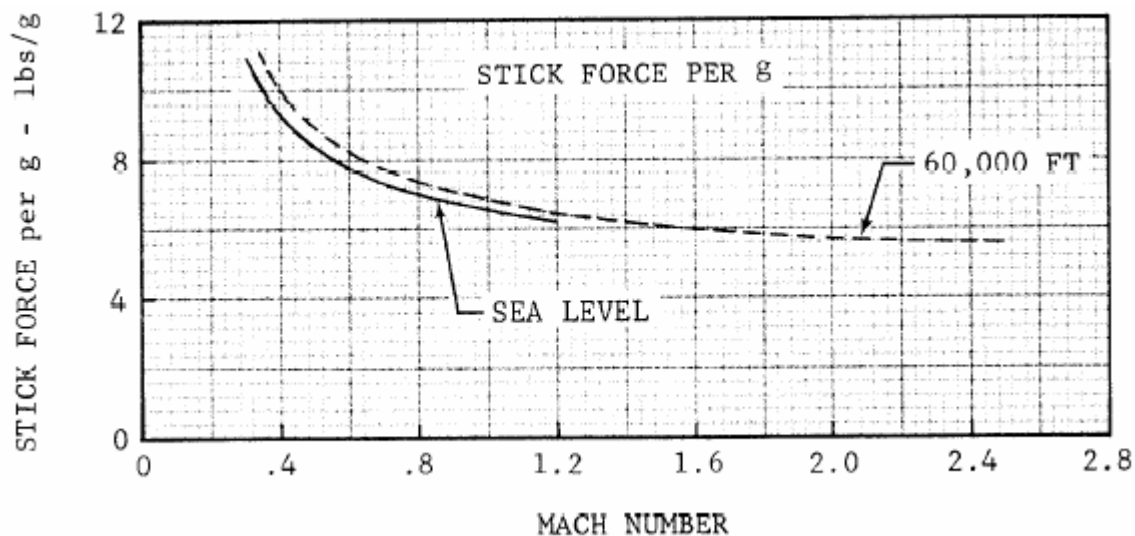

Figure 51: Stick Force per G-Load [23]

Lateral command augmentation provides for constant roll rate per lateral stick deflection by comparing actual roll rate to commanded roll rate. The error was used as in the longitudinal case to increase or reduce control surface deflections [23]. There was no directional command augmentation.

Stability augmentation comes from roll, pitch, and yaw damping [23]. When selected on, these dampers improve the dynamic stability of the aircraft. The aircraft has a restricted flight envelope with the dampers off [23]. The yaw damper also provides automatic turn coordination [23].

6.3.10.7 Stability Effects of Wing Sweep

The aircraft was stable for all sweep angles. Several factors combine to cause this. Longitudinal static stability is achieved when the center of gravity is forward of the aerodynamic center. As the wings were swept back in the F-111, the aerodynamic center and the center of gravity moved back. The amount the aerodynamic center moved depended only on the sweep angle, while the change in center of gravity depended on the sweep angle and the amount of fuel in its wings. The fuel in the wings was burned off first, so less weight went aft by the time the wings were swept back in a flight. The F-111 had outboard positioned wing pivots based on a NASA study in 1961 showed that such a configuration reduced changes in longitudinal stability for variable sweep aircraft. The outboard position meant that less of the wing changed position with sweep. At high speeds, the body of the aircraft significantly contributed to the total lift. In general, aft movement of the aerodynamic center makes an aircraft more stable, and aft movement of the center of gravity makes an aircraft less stable. So the combination of aft movement of the aerodynamic center

and the contribution of the body to lift countered the destabilizing effects of the aft movement of the center of gravity with sweep. Any small remaining effects from a wing sweep were hidden from the pilot by the stability augmentation system [25]. There were no stability transients during sweep.

Normal operation up to 0.8 Mach call for a 26° sweep, and a 45° or greater sweep for supersonic flight [23]. At 26°, the non-pivoting outer wing pylons line up with the airflow. Higher sweep angles increase stall speed and angle of attack. At subsonic speeds and 45° or greater sweep, spoiler lock-out significantly reduces roll control authority [23]. Also at high sweep angles, roll angles greater than 60° resulted in excessive sideslip [23]. Other flying qualities were good for all sweep angles.

There was a directional transient that caused Dutch Roll (short period lateral oscillations) and mild buffeting in the transonic regime [23]. Stall angle-of-attack (AOA) was 20° with flaps and slats extended. AOA above 8-10° can cause buffeting at high speeds.

Wing-sweep contributed to stability at low-level high-speed flight. Highly swept or delta wings have a shallower lift slope than straight wings. This means that as angle-of-attack varies, the lift on the aircraft varies less, and buffeting will be reduced. Pilots noted that the F-111 gave a very smooth ride at low levels where other aircraft would have heavy buffeting [26]. This was important for the F-111's terrain following mission. Flying long-range with heavy buffeting is very taxing on crew. The smooth ride of the F-111 reduced crew fatigue keeping them alert for their often very dangerous missions [26].

6.3.10.8 Horizontal Tail

In addition to providing lateral control in an unconventional manner, the horizontal tail surfaces were against convention as lifting surfaces. This gives a better lift-to-drag ratio, weight savings, and improved maneuverability [14]. The horizontal tail surfaces also had anhedral for high speed directional stability.

6.3.11 Crew Escape Module

The crew escape module was the emergency egress system for the F-111. The module was very different from more typical ejection seats in most fighter aircraft. It was designed for crew survival in ejections throughout the entire flight envelope including low-level high Mach and high altitude, high Mach flight. It was designed to work down to zero altitude at 0 kts and on or under water [12]. There was no provision for modifying the ejection from an inverted airplane. The crew module's predecessor was the B-58 escape capsules, which slammed a cover over each crewmember and ejected them in individual containers. The F-111 was the first aircraft to enclose the crew in a single module.

The module was composed of the pressurized aircraft cockpit, the forward portion of the wing glove, an emergency oxygen system, a rocket, recovery parachutes, and impact and flotation bags [27]. Survival gear was contained behind crew headrests [27]. The module protected the crew from water or other hazardous environments and required no personal parachute or individual survival gear [27]. The module had sensors that would separate the module from the aircraft in the event of water landing. This way, a sinking airplane would not suck the crew underwater. The phases of ejection were explained below.

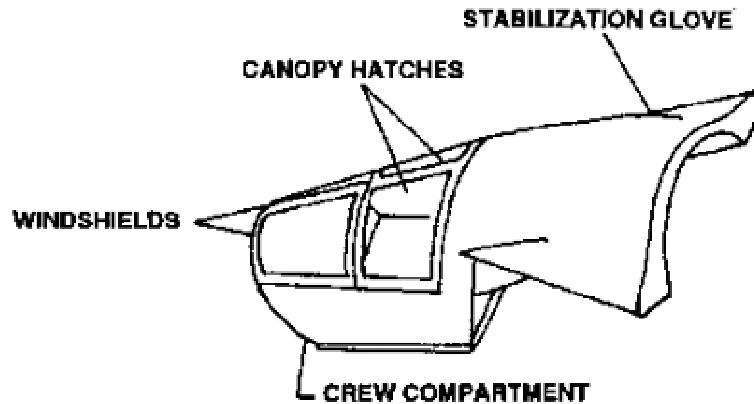

Figure 52: Crew Escape Module [Coynes]

6.3.11.1 Escape Module Separation

Either crewmember could initiate the ejection sequence by squeezing a D-shaped ejection handle and pulling up. Explosive charges cut through the metal holding the crew module to the rest of the aircraft and guillotines severed electrical connections, control wires, and antennas [27]. The 40,000 lb rocket motor fired to propel the module up and away from the aircraft [21].

6.3.11.2 Stabilization

Immediately upon module separation the module was entering an air stream that could be very low airspeeds or over Mach 2. Several devices were employed for stabilization of the module. The wing glove / stabilizer prevented pitch down [27]. Spring actuated stabilization flaps prevented pitch up in a transonic ejection [27]. Spring actuated pitch flaps trimmed out the module [27]. A small stabilization / braking parachute also deployed. As the rocket motor burned out, chaff was released as an extra precaution against lingering missiles searching for a target [11].

The recovery chute deployed reefed to reduce shock loads. Once the lines were stretched and there was some load on the chute, the reef was cut to allow the chute to fully deploy [27]. Impact bags were inflated on the bottom of the module.

6.3.11.3 Landing

On landing, blow-out plugs on the impact bags to absorbed some of the shock of landing. In a water landing, flotation bags could be inflated to keep the module floating and up right. The module was watertight. If the aircraft landed in water without an ejection, the crew could separate from the aircraft to avoid being pulled under [27].

An illustrated ejection sequence is shown in the figure below:

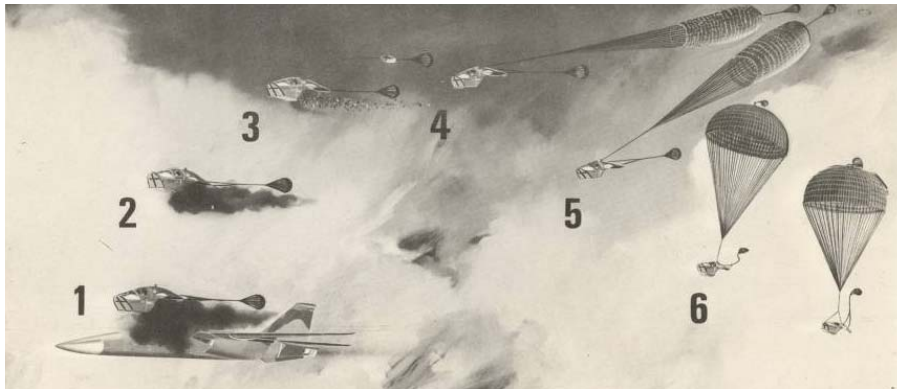

Figure 53: Ejection Sequence [F-111 Escape Module, Phillips]

The crew escape module was used several times in operations, both in combat and non-combat situations. There was no good data of crew deaths due to failed ejection due to the nature of the F-111 mission (see section 3.4.1). Despite this, there were many instances where the crew of a doomed F-111 was saved by the crew module. Additionally, there were no known or confirmed instances where the crew was found dead in an ejected module [17].

6.4 Sub-system Interfaces

Table 6 on the next page is an N^2 diagram depicting the functional interactions between the major subsystems. Each cell depicts an output from the subsystem on the leftmost column as an input to the subsystem on the top row.

Note that the various subsystems are highly coupled and interdependent. In particular, the cockpit and avionics, which represent interactions with the pilots, is the most heavily interdependent with the rest of the subsystems. The hydraulic and pneumatic system, together with the electrical system, provide actuation and power to all the other subsystems, and form an integral part of the aircraft. These two systems, in turn, derive all power from the engine, emphasizing the importance of the powerplant in the overall design of the aircraft. Furthermore, the engine is highly coupled with the hydraulic system: the engine generates power for the hydraulic system, while the hydraulic system controls airflow into the engine by varying inlet geometry.

Table 6: N² Diagram for F-111 major subsystems

From \ To	Airframe	Wings and Sweep Mechanism	Propulsion	Fuel System	Electrical System	Hydr. and Pneumatic System	Payload	Landing Gear	Cockpit and Avionics	Flight Control System	Crew Escape Module
Airframe			Engine mounting	Space for fuselage tanks	Provides space	Provides space		Stowage during flight	Provides space	Provides space	Provides space
Wings and Sweep Mechanism	Lift			Provides space for wing tanks		Wing sweep feedback	Hardpoints for pylon stations		Wing sweep data		Part of forward wing for stability
Propulsion	Thrust	Thrust			Power generation	Power generation			Data sent		
Fuel System			Fuel engine						Fuel level data		
Electrical System	Anti-icing		Ignition	Power to pumps					Power for electronics	Power to controls	
Hydr. and Pneumatic System	Weapon bay doors	Wing sweep actuation	Vary inlet geometry		Emergency electrical generation		Weapon trapeze	Extension, retraction, brakes, steering		Actuation of control surfaces	
Payload				External tanks							
Landing Gear	Landing, braking and parking								Gear status		
Cockpit and Avionics		Wing sweep control	Throttle control	Fuel supply mode control, fuel dump	Generator on/off switch		Payload release control, Fire-power control	Gear up/down control		Pilot input, Auto-pilot and TRR	
Flight Control System	Commands to tail and rudder	Commands to spoilers, slat and flaps									
Crew Escape Module									Provides space		



6.5 Weight

Weight data for the F-111 in various resources is conflicting and incomplete. Various resources have different numbers for aircraft weights. The one consistency in weight data was that later publications reported higher weight showing that the weight of the F-111 increased over time. This is a common occurrence in most aircraft as improvements are made (especially in engines) and envelopes are expanded as the aircraft is proven over time. Among various resources, the empty weight of the F-111A varied from 46,000 lb to 47,500 lb.

Early in the TFX program the Navy and the Air Force were at odds over gross weight. For the Air Force, low-level supersonic range and buffeting drove up gross weight. For the Navy, carrier suitability drove down weight (and size). The Navy wanted an airplane that was 55,000 lb max and the Air Force wanted 75,000 lb minimum [5]. The final maximum take-off weights proposed by General Dynamics in its 1962 winning proposal were [14]:

F-111A	69,000 lb
F-111B	63,000 lb

During development, the F-111 gross weight grew so much that it had to enter a Super Weight Improvement Program (SWIP). SWIP re-design began in January of 1964 [28]. In the first month of the program, 42 weight saving changes were proposed. The design made it into the last developmental aircraft, number 12 for the F-111A [1]. Weight was reduced by 4,000 lb through SWIP [1].

Despite SWIP improvements, the weight of the aircraft continued to grow. By November 1964 the first development aircraft gross weights were [29]:

F-111A	77,306 lb
F-111B	71,380 lb

A pie chart breakdown of weight of the F-111A from proposal is shown in Figure 54.

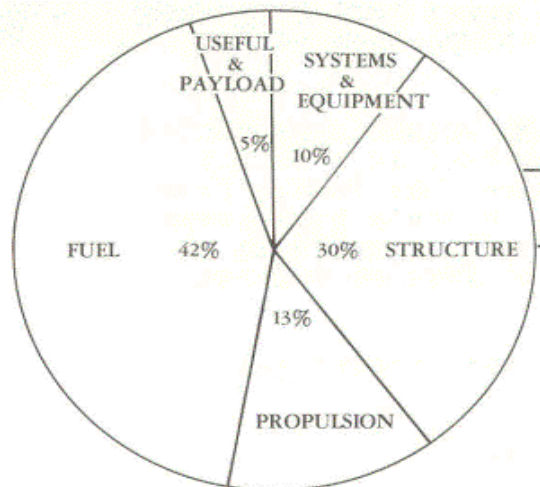

Figure 54: Proposed Weight Breakdown [14]

The Navy’s pull-out from the F-111 program likely impacted the growth of the F-111A. F-111A weights as reported in 1987 [30]:

Empty Weight:	46,172 lb
Combat Weight:	63,051 lb
Gross Weight:	82,819 lb
Max T.O. weight:	98,850 lb

Available weights for F-111 variants are below:

Table 7: F-111 Weights [30]

	F-111A	F-111B	F-111F	EF-111A
Empty	46,172	46,000	47,450	55,275
Combat	63,051	68,365	62,350	70,000
Gross	82,819	72,421	95,333	72,750
Max T.O.	98,850	77,566	100,000	89,000

6.6 Development Cost Breakdown

6.6.1 The Reason for a Joint Program: a “One billion dollar saving”

Although it is known that cost reduction was the driving force to develop a common aircraft for both the Air Force and the Navy, the effectiveness of the idea is generally contested a posteriori. However, data on the subject is blurred and scattered and dependent on the kind of accounting used.

The concept behind the joint development of the aircraft was a net saving of \$1 billion in 1960 dollars. In 2003’s dollars, this amount is worth about six times as much. This huge saving was so important that the project was rapidly called the “one billion dollar program”. With reference to Figure 55 displaying the result of studies conducted under Project 34 in 1961 (see Section 5.3 for the description of this project): the cost of a joint project, with 1700 aircraft, had been projected to be \$5 billion (curve labeled “Project 34 Recommended Combined Program”), while two separate projects would have cost more than \$6 billion (“Navy only” and “Air Force only”). The upper curve labeled “F-111A+F-111B 1964” gives an idea of what the real cost was in 1964. Costs include acquisition as well as R&D. Thus in 1964 it was already clear that cost overruns would be a major characteristic of the program. The next figures were hand-written by George A. Spangenberg who was the Evaluation Division Director of NAVAIR until 1973. In the TFX controversy, he cautioned that engineering a plane appropriate for both Air Force and Navy carrier use would be extremely difficult and fought against the "compromises" that in his opinion were making the Navy plane unsuitable for use. Although the following numbers seems *a posteriori* to be



relevant, one should keep in mind that Spangenberg was “on the Navy side” and therefore against the Navy version of the F-111. It has also been decided to keep these figures because of their “historical” value.

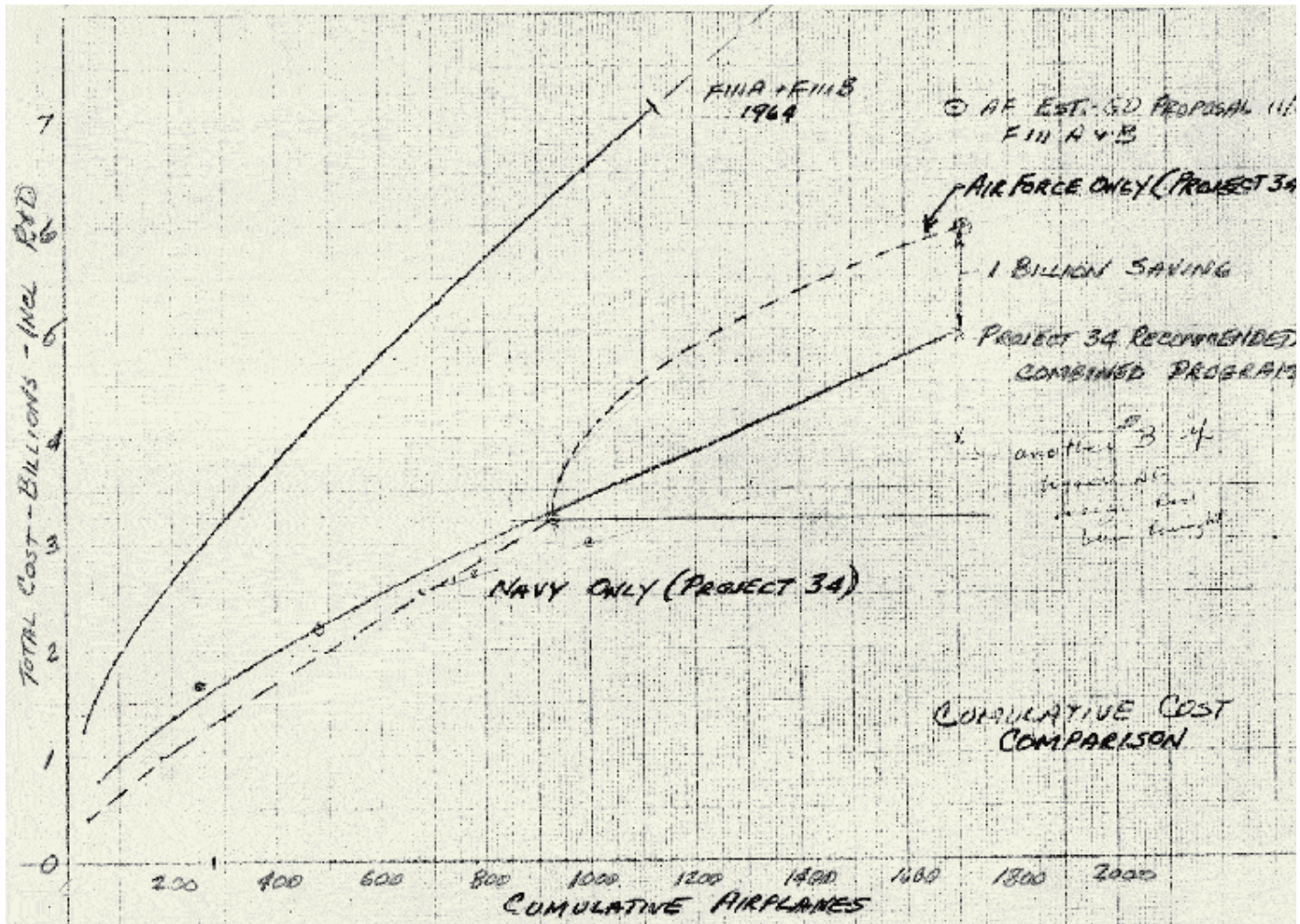

Figure 55: Total cost of the TFX project (from [9])

6.6.2 Unit Costs: An Indicator of Cost Overrun

Figure 56 below was taken from a Memorandum dated February 8, 1965 and shows Unit Cost data provisions of the F-111 in 1961 as a function of number of aircraft produced (research and development cost not included). Basically, the more aircraft purchased, the less cost per unit. The compromise design was supposed to be overall more expensive than the AF design, but cheaper than Navy design. The much larger and heavier Air Force design was initially more expensive than the Navy design but reduces rapidly so that its last buy is but 60% as expensive at the same point in production.

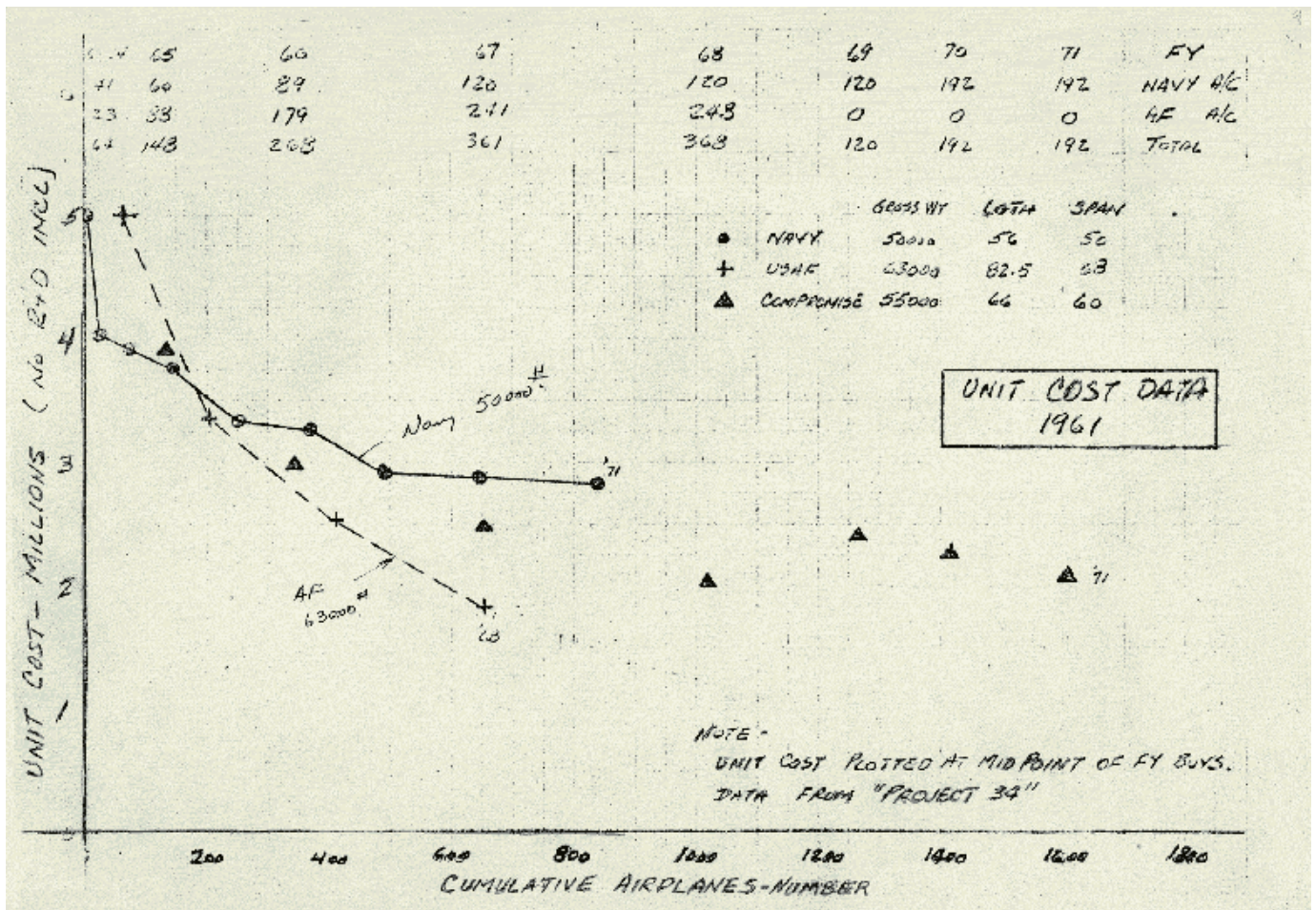

Figure 56: Unit cost predictions, 1961 (from [9])

Comparing this chart with the data published in 1964, it is quite obvious that the predictions of 1961 were quite fanciful, as we see in Figure 57.

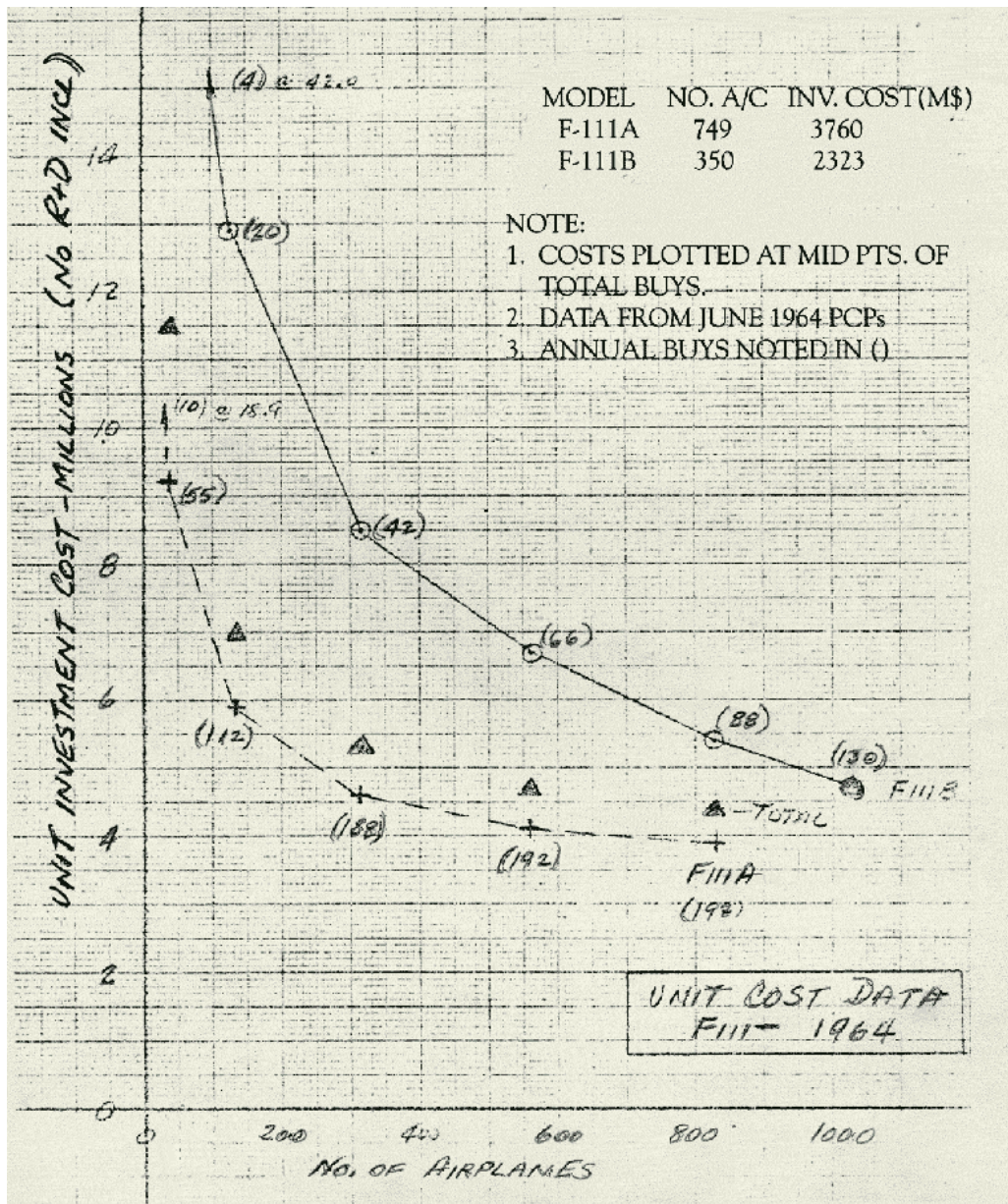

Figure 57: Unit Cost predictions, 1964 (from [9])

Figure 57 shows the estimates of acquisition and the evolution of the Unit Cost as a function of the number of airplanes. Note that instead of the \$4 million max. per unit predicted in 1961 the price had dramatically risen to \$10 million (1964 dollars), which was more than twice that expected three years before. There is no longer a crossing point where the F-111A became cheaper than the F-111B. The F-111B has more electronic equipment, but it is procured later, relatively, than the F-111A.

In the next figure the comparison is drawn between the unit costs as they were predicted in 1961 versus 1964. Estimations used 1964 dollars vs. 1961 dollars but the

difference between the unit costs cannot be only explained by this only factor. It can be seen that the flattened-out costs were at least double those on which the original Project 34 recommendation was made, a main factor of cost overrun, mainly due to change of requirements. At this time, a cumulative cost plot can be plotted as seen in Figure 55. It is seen that that cost is about 2 Billion above the original estimate, although the number of aircraft has decreased by 35% from 1726 to 1122 from 1961 to 1964.

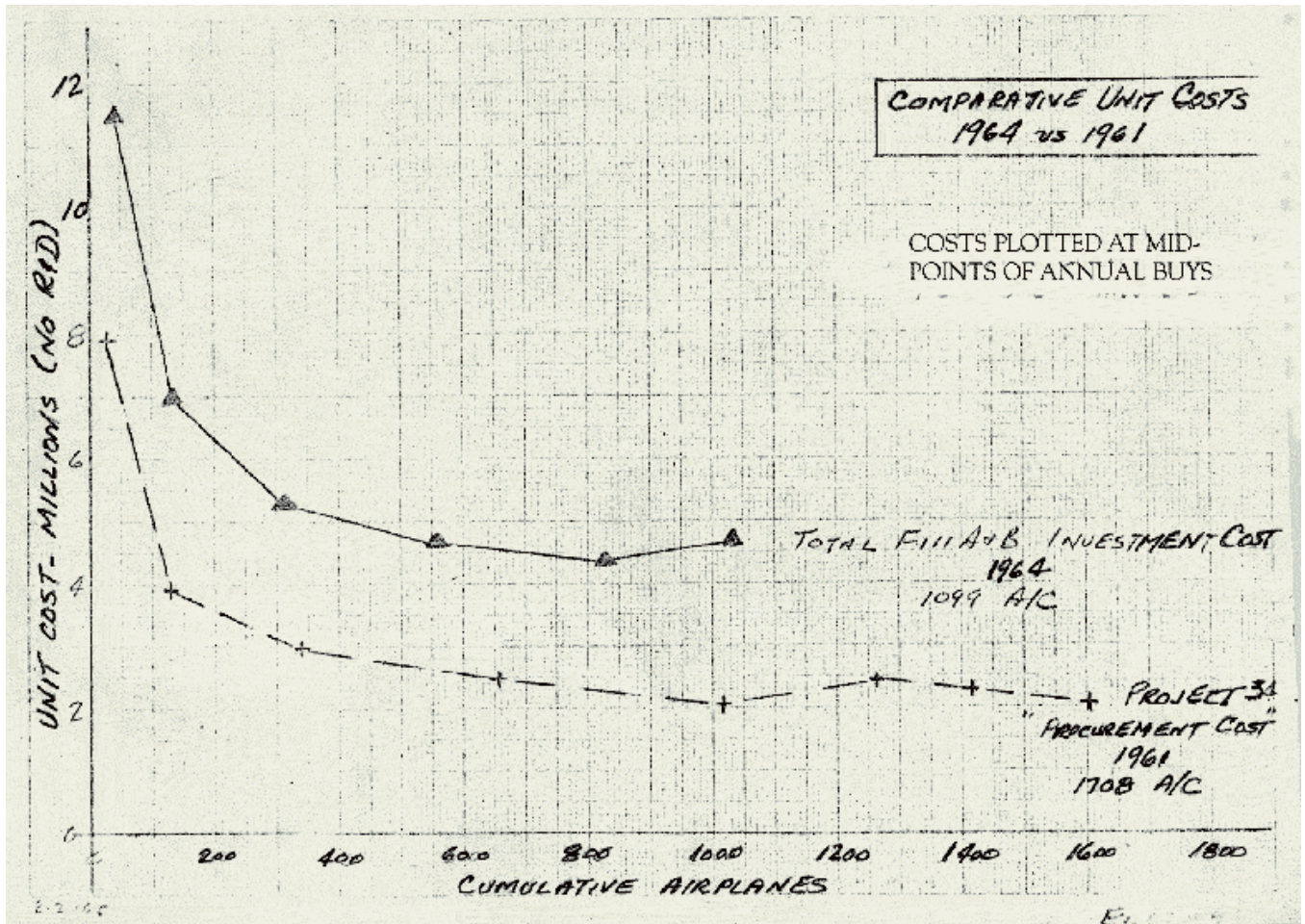

Figure 58 Comparative Unit costs 1964 vs 1961 (from [9])

Overall, the F-111 project turned out to be about twice as expensive as originally intended [28]. According to many sources this was primarily because of the Navy's withdrawal from the program, which resulted in only one service using an aircraft that was designed to play a multi-service role. But from the evolution of costs during the development phase it is clear that cost overrun was initiated before 1968, mainly for change in requirements from both USAF and Navy. The F-111 was over-designed for its purposes, and ended up costing too much. Because of the highly change in the unit cost, predictions made

in the early 60s were totally unreliable. Therefore GD had to balance its overrun due to change of requirements and cancellations by increasing the Unit Cost for each aircraft.

6.7 History of Program Cost

6.7.1 The Proposal

The first data on program cost were published by GD in its Sept. 1961 proposal. In order to show that their costs were realistic and that they would remain under control as the program progressed, they gave a detailed description of their management methods, and recalled their results from the preceding 5 years, during which they had negotiated over \$2 billion dollars worth of contracts that had been performed within 0.6% of estimated cost. GD estimated the cost as shown in Figure 59: they first computed an estimate based on firm commitments for materials or subcontracts. Then, they evaluated in-plant labor and overhead based on realistic projections of employment level, labor rates, and man-hours developed from prior experience in similar programs. Figure 59 shows the division of costs for the TFX. The first observation one can make is that they did not try to estimate overall program costs related to changing requirements although it has been seen previously (see Section 6.6.2) that these changes of requirements have driven a large amount of cost overrun in the 1961-1964 period, as it is shown in section 6.7.2.

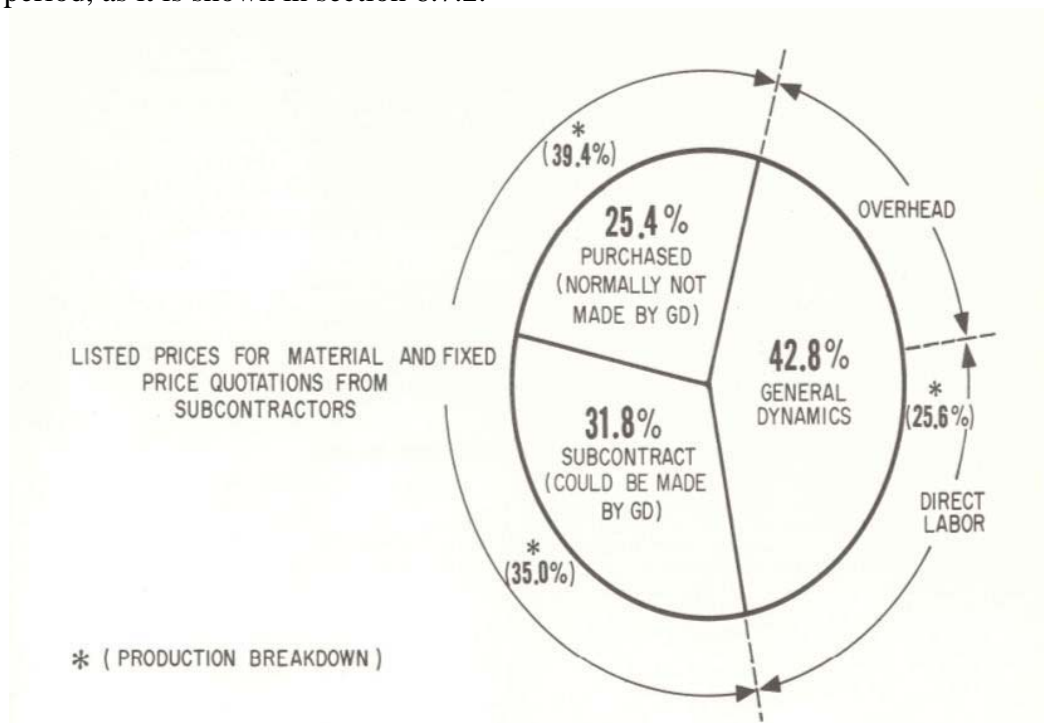

Figure 59: Cost breakdown, from [10]

6.7.2 Program Costs Over the Development Timeline

Cost was a significant issue the F-111 Program: every request had to be fully justified. Congress issued several reports: in the mid-60's a first study evaluated that at mid-program 30% to 60% of the total cost had been spent, a quite encouraging estimation. Nevertheless as seen previously the key points are that ever-increasing costs occurred in the F-111 development program as well as rapid changes in estimations. They were mostly due to frequent modifications of requirements from both services. Because the F-111 was a very political program, strong controversies were generated and many congressional reports were issued regarding the development cost without a partial objectivity. Once the overrun was clearly identified it was too late to step back in the program, and the only way to save money on the program was to reduce the number of units produced.