

2.003 Engineering Dynamics

Problem Set 5--Solution

Problem 1:

Use symmetry rules to find a set of principal axes that pass through the center of mass for each of the rigid bodies in the four figures below. In each case cite the symmetry rule used to obtain the axes you have chosen.

- a) The x - z and y - z axes lie in planes of symmetry. A perpendicular axis to each plane of symmetry is a principal axis. The 3rd principal axis need only be perpendicular to the first two. The origin may be placed at the center of mass, but is not required to be at the mass center.

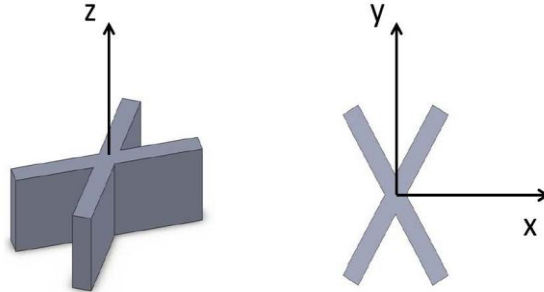

- b) The y - z and x - y axes lie in planes of symmetry. Perpendicular axes to each plane of symmetry are principal axes. The 3rd principal axis need only be perpendicular to the first two. The origin may be placed at the center of mass, but is not required to be at the mass center.

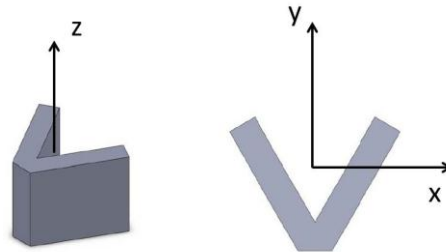

- d) The y - z and x - y axes lie in planes of symmetry. Perpendicular axes to each plane of symmetry are principal axes. The 3rd principal axis need only be perpendicular to the first two. The origin may be the center of mass.

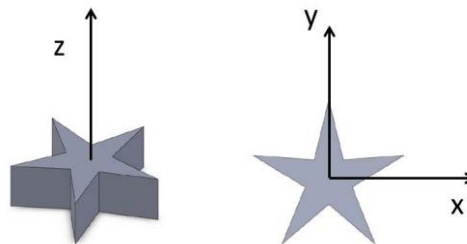

- d) The y axis is an axis of symmetry. The x and z axes need only be perpendicular to the y axis and to each other.

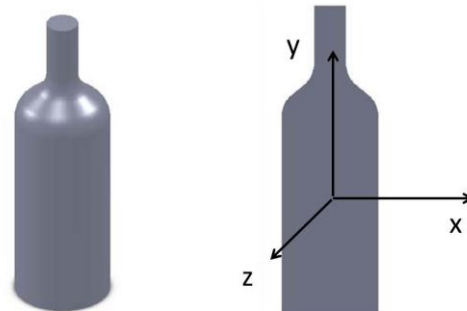

Problem 2:

A block of mass M is constrained by rollers to motion in the x direction. A small mass m is attached at point B to the end of a massless rigid arm. The other end of the arm is attached at a point A which is fixed to the cart. Together the arm and mass make up a rotor which rotates about an axis fixed at A to the cart. The angle the arm makes with a horizontal reference passing through A is given by $\vartheta(t) = \omega t$. The length of the arm is 'e', the distance from A to B . The position of the cart in the inertial frame is given by the coordinate $x\hat{i}$.

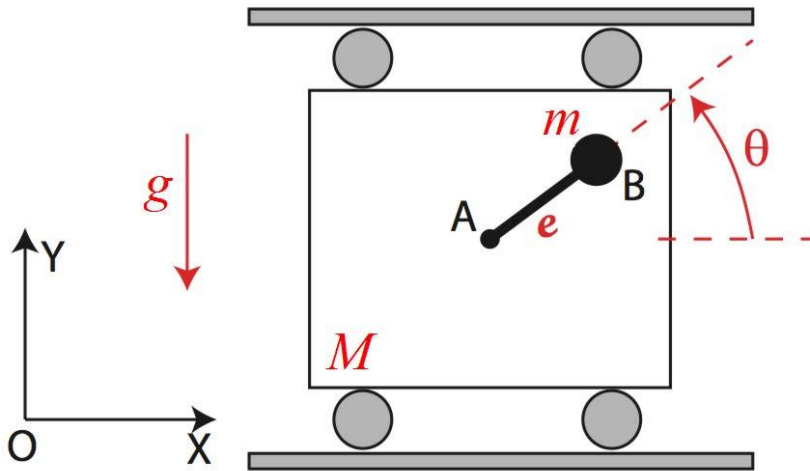

In Problem Set 3 we found the forces that the arm must exert on the mass, m , to cause it to move in a circular path about point A . These forces may be expressed as:

$$\vec{F}_{rod} = +m[\ddot{x} - e\dot{\theta}^2 \cos(\theta)]\hat{i} + m[g - e\dot{\theta}^2 \sin(\theta)]\hat{j}$$

- Find an equation of motion of the cart by using Newton's third law to express the forces of the rod on the cart of mass M .

Solution:

The cart of mass ' M ' is free to move only in the x direction. Therefore, a direct application of Newton's 2nd Law in the x direction will yield the EOM of the mass of the cart.

$$\sum \vec{F}_{M,x} = M\ddot{x} \quad (1)$$

In this problem the only forces in the x direction are those that the rotating arm places on the mass, M, at point A. This arm also places a force on the rotating mass, m, which was determined in Problem set 3 and is given above. In order for the massless arm to be in force equilibrium, the force the arm places on 'm' must be equal and opposite to the force the arm places on 'M'.

$$\vec{F}_{rod,M} = -m[\ddot{x} - e\dot{\theta}^2 \cos(\theta)]\hat{i} + m[g - e\dot{\theta}^2 \sin(\theta)]\hat{j} \text{ and the x component is therefore simply:} \quad (2)$$

$$\vec{F}_{rod,M,x} = -m[\ddot{x} - e\dot{\theta}^2 \cos(\theta)]\hat{i}$$

Putting the result from (2) into Equation (1) yields:

$$\sum F_{M,x} = M\ddot{x} = -m[\ddot{x} - e\dot{\theta}^2 \cos(\theta)], \text{ which may be rearranged to yield} \quad (3)$$

$$(M + m)\ddot{x} = me\dot{\theta}^2 \cos(\theta)$$

Although this completes the problem as asked, by solving for the acceleration, a useful insight is obtained.

$$\ddot{x} = e \frac{m}{(M + m)} \omega^2 \cos(\omega t), \text{ which can be integrated to find } x(t). \quad (4)$$

The system consisting of both masses and the arm has no external forces acting upon it. Therefore, as the arm rotates the center of mass of the system must not experience any acceleration. It does not move. The distance that the mass M moves may be obtained by

integrating equation (4), resulting in $x = -e \frac{m}{(M + m)} \cos(\omega t),$

The moment $x(t)$ of the large mass, M, is exactly the amount needed to compensate for the motion of the small mass as it moves in the opposite direction with an amplitude 'e'. Thus the center of mass of the system does not move.

Problem 3:

Two identical masses are attached to the end of massless rigid arms as shown in the figure. The vertical portion of the rod is held in place by bearings that prevent vertical motion, but allow the shaft to rotate without friction. The shaft rotates with angular velocity Ω with respect to the O_{xyz} inertial frame. The arms are of length L . The frame $A_{x_1y_1z_1}$ rotates with the arms and attached masses. Note that the angle ϕ is fixed.

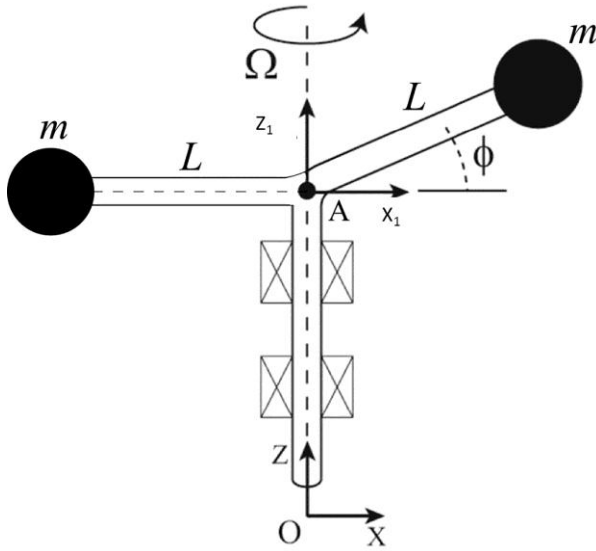

- a) Compute the angular momentum $\vec{H}_{/A}$ for this two-mass system with respect to point A.

Point A is not moving and therefore is an inertial point. The two mass particles in this system make a rigid body. The only velocity components result from the rotation of the body about an axis passing through 'A'. Therefore:

$$\vec{H}_{/A} = \sum_i \vec{r}_{i/A} \times \vec{p}_{i/O} = \sum_i \vec{r}_{i/A} \times (\vec{\omega}_{/O} \times \vec{r}_{i/A}) m_i \quad (1)$$

Because point A does not move, $\vec{\omega}_{/O} = \vec{\omega}_{/A} = \Omega \hat{k}_1$

Let m_1 be the mass to the left in the figure and m_2 be the mass to the right. Then,

$\vec{r}_{1/A} = -L \hat{i}_1$ and $\vec{r}_{2/A} = L(\cos(\phi) \hat{i}_1 + \sin(\phi) \hat{k}_1)$. Substituting into (1) yields:

$$\vec{H}_{/A} = m_1 L^2 \Omega \hat{k}_1 + m_2 L^2 \Omega (\cos^2(\phi) \hat{k}_1 - \sin(\phi) \cos(\phi) \hat{i}_1)$$

Since $m_1 = m_2 = m$, then

$$\vec{H}_{/A} = mL^2 \Omega (1 + \cos^2(\phi)) \hat{k}_1 - mL^2 \Omega \sin(\phi) \cos(\phi) \hat{i}_1$$

b) Express the angular velocity $\omega(t)$ of the rotating system as a column vector using unit vectors in the rotating $A_{x_1y_1z_1}$ frame.

$$\vec{\omega}_{/O} = \begin{Bmatrix} \omega_{x_1} \\ \omega_{y_1} \\ \omega_{z_1} \end{Bmatrix} = \begin{Bmatrix} 0 \\ 0 \\ \Omega \hat{k}_1 \end{Bmatrix}$$

c) Express $\vec{H}_{/A} = [I]\{\omega\}$, where $[I]$ is a 3×3 matrix and $\omega = \begin{Bmatrix} 0 \\ 0 \\ \Omega \end{Bmatrix}$.

The most direct way to do this is to compute the elements of the inertia matrix from their basic definitions in terms of the summation of the moments of inertia of individual particles.

$$I_{xx} = \sum_i m_i (y_i^2 + z_i^2), \quad I_{yy} = \sum_i m_i (x_i^2 + z_i^2), \quad I_{zz} = \sum_i m_i (y_i^2 + x_i^2),$$

$$I_{xy} = -\sum_i m_i x_i y_i = I_{yx}, \quad I_{xz} = -\sum_i m_i x_i z_i = I_{zx}, \quad I_{yz} = -\sum_i m_i y_i z_i = I_{zy},$$

In this case there are two particles. From part a) the position vectors of the two particles are given by: $\vec{r}_{1/A} = -L\hat{i}_1$ and $\vec{r}_{2/A} = L(\cos(\phi)\hat{i}_1 + \sin(\phi)\hat{k}_1)$

Therefore the location of m_1 is at $(x_1, y_1, z_1) = (-L, 0, 0)$ and m_2 is located at $(x_2, y_2, z_2) = (L\cos(\phi), 0, L\sin(\phi))$

Substitution into the expressions above for the individual elements of the inertia matrix yields:

$$[I_{/A}] = \begin{bmatrix} I_{xx} & I_{xy} & I_{xz} \\ I_{yx} & I_{yy} & I_{yz} \\ I_{zx} & I_{zy} & I_{zz} \end{bmatrix} = \begin{bmatrix} mL^2 \sin^2 \phi & 0 & -mL^2 \sin \phi \cos \phi \\ 0 & 2mL^2 & 0 \\ -mL^2 \sin \phi \cos \phi & 0 & mL^2 (1 + \cos^2 \phi) \end{bmatrix}$$

Just to check, compute the matrix product

$$\{\vec{H}_{/A}\} = [I_{/A}]\{\omega\} = [I_{/A}] \begin{Bmatrix} 0 \\ 0 \\ \Omega \end{Bmatrix} = \begin{Bmatrix} -mL^2 \Omega \sin \phi \cos \phi \hat{i}_1 \\ 0 \\ mL^2 \Omega (1 + \cos^2 \phi) \hat{k}_1 \end{Bmatrix} \text{ the same as was obtained in part a).}$$

d) Compute $\frac{d\vec{H}_{/A}}{dt}$ and note that Ω is not assumed to be constant. From part a) or d) the expression for $\vec{H}_{/A}$ is $\vec{H}_{/A} = mL^2 \Omega (1 + \cos^2(\phi)) \hat{k}_1 - mL^2 \Omega \sin(\phi) \cos(\phi) \hat{i}_1$ and therefore

$$\frac{d\vec{H}_{/A}}{dt} = mL^2\dot{\Omega}(1 + \cos^2(\phi))\hat{k}_1 - mL^2\dot{\Omega}\sin(\phi)\cos(\phi)\hat{i}_1 - mL^2\Omega^2\sin(\phi)\cos(\phi)\hat{j}_1$$

Note that the only time dependent terms in the expression for $\vec{H}_{/A}$ are

Ω and \hat{i}_1 ; \hat{k}_1 does not rotate, and therefore $\frac{d\vec{H}_{/A}}{dt}$ has only three terms.

e) Find the torque about A and express it as a vector $\{\vec{\tau}_{/A}\} = \begin{Bmatrix} \tau_x \hat{i}_1 \\ \tau_y \hat{j}_1 \\ \tau_z \hat{k}_1 \end{Bmatrix}$, where \hat{i}_1, \hat{j}_1 , and \hat{k}_1 are unit

vectors in the rotating $A_{x_1y_1z_1}$ system. In general the sum of the external torques on a rigid body is given with respect to any fixed or moving point, 'A' is given by:

$$\sum_i \vec{\tau}_{i/A} = \left(\frac{d\vec{H}_{/A}}{dt} \right)_{O_{xyz}} + \vec{v}_{A/O} \times \vec{P}_{C/O}, \text{ where } \vec{P}_{C/O} \text{ is the linear momentum of the rigid body. In this}$$

case $\vec{v}_{A/O} = 0$, because A is a fixed point. Therefore Euler's law for the sum of torques on this rigid body with respect to the fixed point 'A' simplifies to:

$$\sum_i \vec{\tau}_{i/A} = \left(\frac{d\vec{H}_{/A}}{dt} \right)_{O_{xyz}} = mL^2\dot{\Omega}(1 + \cos^2(\phi))\hat{k}_1 - mL^2\dot{\Omega}\sin(\phi)\cos(\phi)\hat{i}_1 - mL^2\Omega^2\sin(\phi)\cos(\phi)\hat{j}_1$$

f) Where could you place a single additional mass, connected to a massless arm, such that $\frac{d\vec{H}_{/A}}{dt}$ would yield torque with a component only aligned with the z direction?

This system is dynamically imbalanced because mass m_2 on the right side in the figure creates torques about the x and y axes due to the offset of the mass in the z direction. Conceptually, the easiest way to dynamically balance this rotor is to add mass to the system in such a way that the existing axes attached to the body, become principal axes (the axes referred to those in the $A_{x_1y_1z_1}$ frame). This can be done by inspection by making the x_1y_1 plane a plane of symmetry for the rigid body. The simplest way to do this is to add a third mass equal to m_2 but offset the same distance in the $-z$ direction. The system would look like the following figure: The z_1x_1 and x_1y_1 planes are now both planes of symmetry. Therefore the x_1, y_1 , and z_1 axes are all principal axes and the system is dynamically balanced for rotation about one of these axes. In this case the rotation is about the z_1 axis.

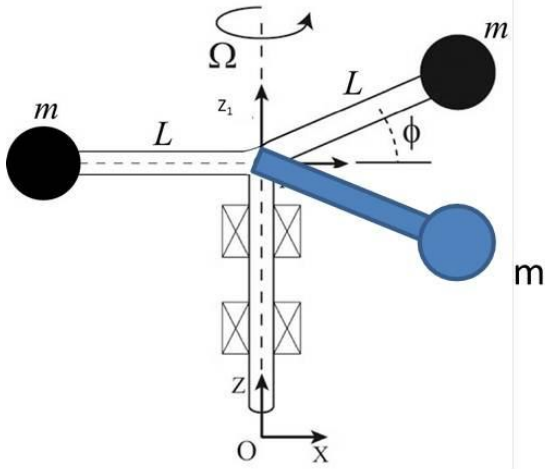

The system would be dynamically balanced but not statically balanced, because the center of mass of the system is not at the axis of rotation.

Problem 4:

A motorized cart is carrying a box of mass $m = 800 \text{ kg}$ on its flat bed. The static coefficient of friction between the cart's bed and the box is $\mu_s = 0.3$. The center of mass of the box is 1.0 m above the bed of the cart. The length of the box is $2b = 0.2 \text{ m}$ and the center of mass of the box is located at a distance $b = 0.1 \text{ m}$ from the edge of the crate. The cart is travelling on a level floor and gravity is at work.

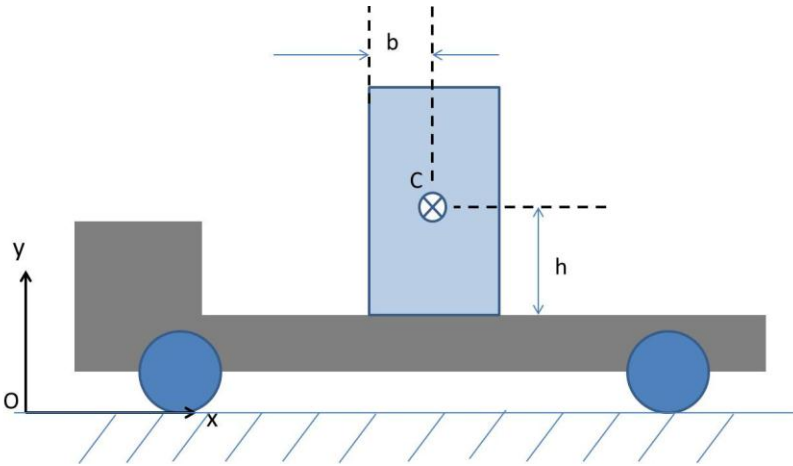

- a) Find the maximum horizontal acceleration of the cart that does not cause the box to slip nor tip.

The acceleration of the cart that would result in slip would be given by

$$\sum_x \vec{F} = M_{\text{box}} \ddot{x} \geq \mu_s N = \mu_s M_{\text{box}} g$$

$$\Rightarrow \ddot{x} \geq \mu_s g = .3g$$

The acceleration that would result in tipping of the box is when the torque with respect to the lower left corner of the box, produced by the truck's acceleration of the center of mass of the box, exceeds the restoring torque provided by gravity. Begin with a free body diagram of the box, as it begins to tip about its back corner. The weight of the box acts at the center of mass. The normal force on the box shifts to the back corner as the box begins to tip. The normal force exerts no torque about 'A' because the moment arm with respect to 'A' is zero. The friction force produces no torque about 'A' because its line of action passes through 'A'. At this instant in time the free body diagram is

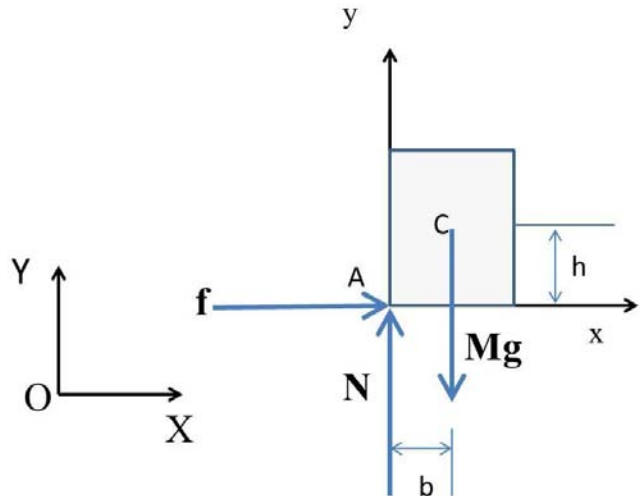

as shown in the figure above.

Euler's law for a rigid body may be written as follows:

$$\sum_i \vec{\tau}_{i/A} = \left(\frac{d\vec{H}_{/A}}{dt} \right)_{O_{xyz}} + \vec{v}_{A/O} \times \vec{P}_{C/O} \quad \text{In this case the momentum of the box,}$$

$$\vec{P}_{C/O} = m\vec{v}_{A/O} \quad \text{and therefore } \vec{v}_{A/O} \times \vec{P}_{C/O} = 0. \quad \text{Therefore}$$

$$\begin{aligned} \sum_i \vec{\tau}_{i/A} &= \left(\frac{d\vec{H}_{/A}}{dt} \right)_{O_{xyz}} = \frac{d(\vec{H}_{/C} + \vec{r}_{C/A} \times \vec{P}_{C/O})}{dt} = \frac{d\vec{H}_{/C}}{dt} + \vec{r}_{C/A} \times \frac{d\vec{P}_{C/O}}{dt} \\ &= \frac{d\vec{H}_{/C}}{dt} + \vec{r}_{C/A} \times M\vec{a}_{A/O} = \frac{d\vec{H}_{/C}}{dt} + \vec{r}_{C/A} \times M\ddot{X}\hat{i} = 0 + (b\hat{i} + h\hat{j}) \times M\ddot{X}\hat{i} \\ &= -Mh\ddot{X}\hat{k} = -Mgb\vec{k} \end{aligned}$$

Since $Mh\ddot{X}\hat{k} \leq Mgb\vec{k}$ then $\ddot{X} \leq g \frac{b}{h} = g \frac{0.1m}{1.0m} = 0.1g$. If the acceleration of the truck is less than 0.1g then the box will not tip. If the acceleration of the truck is less than 0.3g then it will not slide. In this case the box will tip before it slides.

In the above the angular momentum of the box with respect to 'A' has been replaced by a very useful equivalent expression $\vec{H}_{/A} = \vec{H}_{/C} + \vec{r}_{C/A} \times \vec{P}_{C/O}$. Because the box has no angular velocity, the angular momentum about the mass center at 'C', $\vec{H}_{/C} = 0$. In addition, because the position vector $\vec{r}_{C/A}$ is of fixed length and direction, its time derivative is zero and therefore

$$\frac{d(\vec{r}_{C/A} \times \vec{P}_{C/O})}{dt} = \vec{r}_{C/A} \times \frac{d\vec{P}_{C/O}}{dt} = \vec{r}_{C/A} \times M\vec{a}_{A/O} .$$

Problem 5:

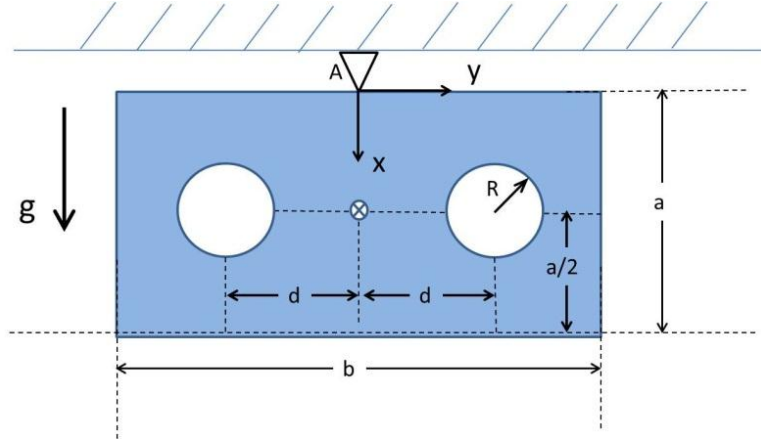

A pendulum consists of a rectangular plate (of thickness t) made of a material of density ρ , with two identical circular holes (of radius R). The pivot is at A.

- Find the location of C, the center of mass of the pendulum.
- Compute $I_{zz/C}$ and $I_{zz/A}$ the mass moments of inertia about C and A respectively with respect to

the z axis. Note: you can use the tables for $I_{zz/C}$ given in many textbooks for various shapes.

- Derive the equations of motion for the system. (Note: do not assume small motions)

Solution:

a). The center of mass of the rectangle is at $x=a/2$, $z=0$ and $y=0$. The two holes are symmetrically placed with respect to the x axis. Hence, removal of the two holes does not move the center of mass in the y direction. The center of mass of the two holes in the x direction is at $x=a/2$, the same as the original rectangle. Hence the removal of the two holes does not move the center of mass in the x direction either. Therefore $(x_{cm}, y_{cm}, z_{cm})=(a/2, 0, 0)$

b). $I_{zz/C}$ and $I_{zz/A}$ may be computed by first finding $I_{zz/C}$ and then using the parallel axis theorem to obtain $I_{zz/A}$. The simplest way to find $I_{zz/C}$ for the rectangle with holes is to realize that $I_{zz/C}$ for the rectangle without holes is the sum of the $I_{zz/C}$ for the rectangle with holes and $I_{zz/C}$ for the holes.

$$I_{zz/C,with\ holes} = I_{zz/C,without\ holes} - I_{zz/C,holes}$$

$$= \rho abt \frac{(a^2 + b^2)}{12} - I_{C,holes}$$

$$I_{zz/C,holes} = 2\rho\pi R^2 t \frac{R^2}{2} + 2\rho\pi R^2 t d^2$$

Where the second term in the line above is from the application of the parallel axis theorem for the holes displaced by d from C.

The mass of the rectangle with holes is given by

$$M_{with\ holes} = \rho[abt - 2\pi R^2t].$$

Putting it together yields the $I_{zz/A,with\ holes}$ that we seek.

$$\begin{aligned} I_{zz/A,with\ holes} &= I_{zz/C,with\ holes} + M_{with\ holes} \frac{a^2}{4} \\ &= \rho abt \frac{(a^2 + b^2)}{12} - 2\rho\pi R^2t \frac{R^2}{2} - 2\rho\pi R^2td^2 + \rho[abt - 2\pi R^2t] \frac{a^2}{4} \\ I_{zz/A,with\ holes} &= \rho abt \left[\frac{b^2}{12} + \frac{a^2}{3} \right] - 2\rho\pi R^2t \left[\frac{R^2}{2} + d^2 + \frac{a^2}{4} \right] \end{aligned}$$

c). To derive the equation of motion: i. first draw a free body diagram.

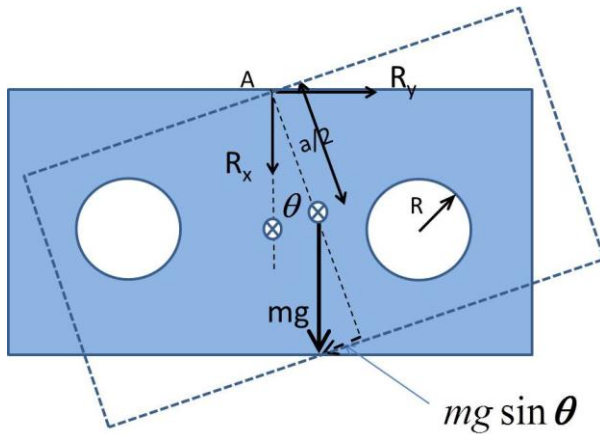

Then use Euler's law for rotation about a fixed point. This is a simple planar motion problem and we can use the simple form:

$$\begin{aligned} \sum_{external} \vec{\tau} &= I_{zz/A} \ddot{\theta} \hat{k} = \frac{a}{2} \hat{r} \times -mg \sin \theta \hat{\theta} = -mg \frac{a}{2} \sin \theta \hat{k} \\ \Rightarrow I_{zz/A} \ddot{\theta} + mg \frac{a}{2} \sin \theta &= 0 \end{aligned}$$

Problem 6:

Two uniform cylinders of mass m_1 and m_2 and radius R_1 and R_2 are welded together. This composite object rotates without friction about a fixed point O . An inextensible massless string is wrapped without slipping around the larger cylinder.

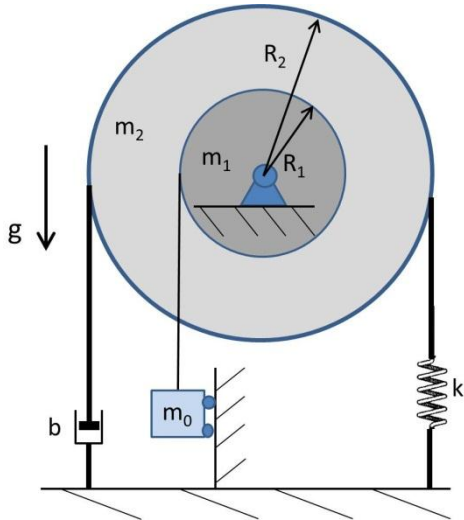

The two ends of the string are connected to the ground via, respectively, a spring of constant k and a dashpot of constant b . The smaller cylinder is connected to a block of mass m_0 via an inextensible massless strap wrapped without slipping around the smaller cylinder. The block is constrained to move only vertically.

- a) Draw a free body diagram for the system.
- b) Derive the equations of motion for the system.

Solution:

a)

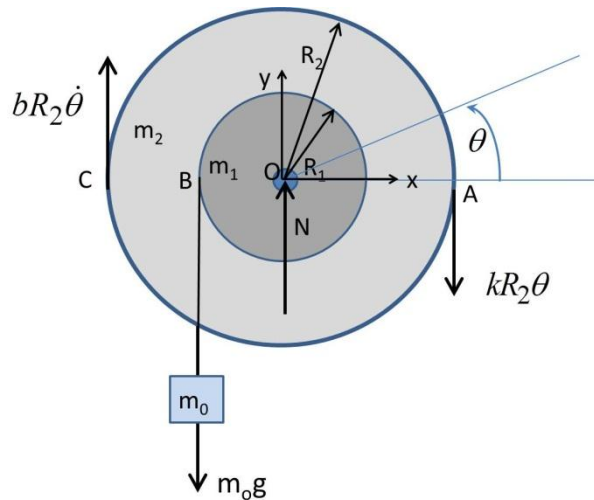

- b) A single coordinate $\theta(t)$ is able to completely describe the motion of the system. It is assumed that $\theta = 0$ is at the unstretched (zero force) position of the spring. An O_{xyz} inertial frame is positioned at the axle. It does not rotate. Euler's law may be applied to a system of rigid bodies as well as to an individual rigid body. By evaluating the angular momentum of the entire system with respect to point 'O' it is possible to avoid having to find the tension in the cord connected to the hanging mass. The cord exerts only an internal force in the system and need not be evaluated. The following expression for the

angular momentum of the system is found:

$$\begin{aligned}\vec{H}_{/o} &= \sum_i \vec{H}_{i/o} = \vec{H}_{rotor} + \vec{r}_{B/o} \times \vec{P}_{m_o/o} \\ &= I_{zz/o} \dot{\theta} \hat{k} + (-R_1 \hat{i} \times (-m_o R_1 \dot{\theta} \hat{j})) = I_{zz/o} \dot{\theta} \hat{k} + m_o R_1^2 \dot{\theta} \hat{k}\end{aligned}$$

where $I_{zz/o} = m_1 \frac{R_1^2}{2} + m_2 \frac{R_2^2}{2}$ and therefore

$$\vec{H}_{/o} = [(m_o + \frac{m_1}{2})R_1^2 + \frac{m_2}{2} R_2^2] \dot{\theta} \hat{k}$$

Because the angular momentum is with respect to a fixed point then Euler's law may be written as follows:

$$\begin{aligned}\sum \tau_{i/o} &= \left(\frac{dH_{/o}}{dt} \right)_{o,xyz} = [(m_o + \frac{m_1}{2})R_1^2 + \frac{m_2}{2} R_2^2] \ddot{\theta} \hat{k} \\ &= [m_o g R_1 - b R_2^2 \dot{\theta} - k R_1^2 \theta] \hat{k}\end{aligned}$$

Rearranging leads to the following equation of motion:

$$[(m_o + \frac{m_1}{2})R_1^2 + \frac{m_2}{2} R_2^2] \ddot{\theta} + b R_2^2 \dot{\theta} + k R_1^2 \theta = m_o g R_1$$

The static torque term on the right hand side will cause this system to have a static rotation which the above EOM could be solved to yield. The rotor and mass will oscillate about this static equilibrium position if given an initial rotation and released.

Problem 7:

A wheel is released at the top of a hill. It has a mass of 150 kg, a radius of 1.25 m, and a radius of gyration of $k_G = 0.6$ m.

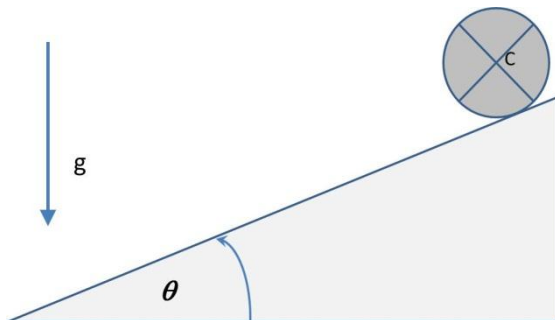

a) If the coefficients of static and kinetic friction between the wheel and the plane are $\mu_s = 0.2$ and $\mu_k = 0.15$ respectively, determine the maximum angle, ϑ , of the inclined plane so that the wheel rolls without slipping.

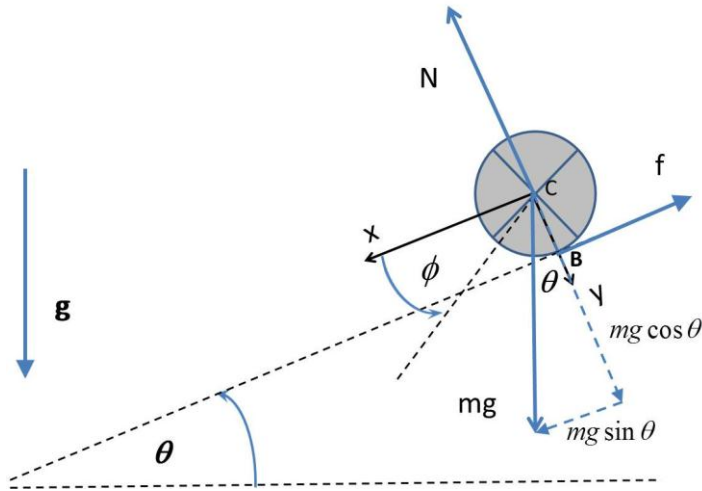

Solution: First prepare a free body diagram. Then assume there is no slip and find an equation of motion, which will have to involve the slope. As long as the wheel does not slip there exists an instantaneous center of rotation at the point of contact, B, with the ground. Only one coordinate is needed to completely describe the motion when slip is not allowed, because translation and rotation are constrained by the relationship that $x = R\phi$.

- a) We begin by summing torques about 'B' the instantaneous center of rotation and apply Euler's law for the sum of torques about a point that is not moving.

$$\begin{aligned} \sum_i \tau_{i/B} &= \vec{r}_{C/B} \times (mg \sin \theta \hat{i} + mg \cos \theta \hat{j}) = -R\hat{j} \times (mg \sin \theta \hat{i} + mg \cos \theta \hat{j}) = mgR \sin \theta \hat{k} \\ &= \frac{d\vec{H}_{i/B}}{dt} = \frac{d(I_{zz/B} \dot{\phi} \hat{k})}{dt} = (m\kappa_G^2 + mR^2) \ddot{\phi} \hat{k} \quad (\text{note use of the parallel axis theorem}) \\ &\Rightarrow (m\kappa_G^2 + mR^2) \ddot{\phi} = mgR \sin \theta \\ &\Rightarrow \ddot{\phi} = \frac{gR \sin \theta}{(\kappa_G^2 + R^2)} \end{aligned}$$

Where we note that radius of gyration is defined as:

$I_{zz/C} = m\kappa_G^2$, where G refers to the center of mass, the same as the meaning of C. Nothing was learned about slip or the friction force. A way to bring the friction force into the discussion is to apply Newtons' 2nd law to the wheel.

$$\begin{aligned} \sum_x \vec{F}_{ext} &= (mg \sin \theta - f) \hat{i} = m\ddot{x} \hat{i}; \text{ dropping } \hat{i} \text{ and solving for } f. \\ f &= mg \sin \theta - m\ddot{x} \leq \mu_s mg \cos \theta = \mu_s N \end{aligned}$$

Because of the no slip condition, $\ddot{x} = R\ddot{\phi}$. With this relationship and the expression found earlier for $\ddot{\phi}$, the following is obtained.

$$f = mg \sin \theta - m\ddot{x} \leq \mu_s mg \cos \theta$$

$$\ddot{x} = R\ddot{\phi} = \frac{gR^2 \sin \theta}{(\kappa_G^2 + R^2)}$$

$$\Rightarrow mg \sin \theta - m \frac{gR^2 \sin \theta}{(\kappa_G^2 + R^2)} \leq \mu_s mg \cos \theta$$

$$\Rightarrow \tan \theta \frac{\kappa_G^2}{\kappa_G^2 + R^2} \leq \mu_s$$

$$\Leftrightarrow \tan \theta \leq \mu_s \frac{\kappa_G^2 + R^2}{\kappa_G^2} = 0.2 \left[\frac{.6^2 + 1^2}{.6^2} \right] = 0.7555$$

$$\theta \leq \tan^{-1}(0.755) = 37.07 \text{ degrees}$$

If the slope exceeds 37.07 degrees the wheel will begin to slip.

MIT OpenCourseWare
<http://ocw.mit.edu>

2.003SC / 1.053J Engineering Dynamics
Fall 2011

For information about citing these materials or our Terms of Use, visit: <http://ocw.mit.edu/terms>.