

MIT OpenCourseWare
<http://ocw.mit.edu>

2.007 Design and Manufacturing I
Spring 2009

For information about citing these materials or our Terms of Use, visit: <http://ocw.mit.edu/terms>.

2.007 – Design and Manufacturing I

Practice Exam on Drawing, CAD, Motors, Pneumatics, and Mechanisms

This practice exam is meant for a 1.5 hour period. It has 7 problems and 100 points total.

NOTE: These are problems we made up and decided not to use on the exam in this form. We thought maybe they were not as clear as we wanted or didn't match our objectives perfectly. So, this practice exam is not quite representative, but practicing on imperfect problems is better than not practicing.

1. (15 points) A designer proposes to change the an electric motor by increasing the number of windings of wire around the armature significantly (e.g., by doubling it). All other parameters of the motor are preserved as they were (radius of the armature, strength of the magnetic field, and so on). Describe the influence (if any) on:

- a) stall torque
- b) no load speed
- c) maximum power

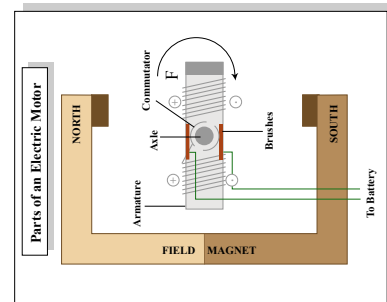
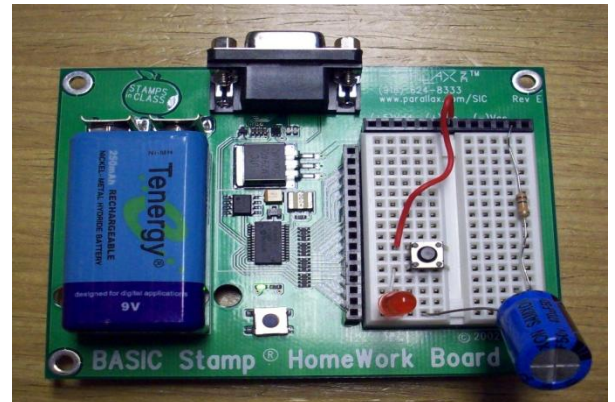

Figure by MIT OpenCourseWare.

2. (5 points) The components shown here (resistor, capacitor, LED, and normally-open-button) are connected in series. The button is pressed and the LED lights up and then slowly dims over the course of 5 seconds. The button is released and 5 more seconds pass. The button is pressed again. Which statement best describes what happens:

- a) The LED lights up and then slowly dims over the course of 5 seconds
- b) The LED starts dim then slowly brightens over the course of 5 seconds
- c) The LED lights up steadily
- d) LED does not light



3. (5 points) In the Pugh method of controlled convergence:
- The datum concept should be a strong design concept so that the team can visualize opportunities to improve on the best available ideas
 - The datum concept should be an average design concept so that the matrix will be filled with a balance of + and – ratings providing the maximum information for decision-making
 - The datum concept should be a weak design concept so that each team member will feel motivated because the design concepts they propose will have more + ratings than – ratings
 - The datum concept should be selected at random to avoid bias in the decision making process
4. (5 points) A vehicle is composed of a box shaped structure with permanent magnet DC motors placed at all four corners and driving all four wheels (through a gear train). All these motors are attached to a 5V NiCad battery pack. The vehicle is climbing a 20 degree incline. The coefficient of static friction between the wheels and the inclined surface is 0.5. The vehicle is proceeding very slowly since the motors are nearly stalled. At that moment, an additional object is placed on top of the vehicle which doubles the weight of the overall vehicle plus its payload. Which statement best describes the events that will transpire?
- The wheels will begin to slip with respect to the surface of the incline, but the vehicle will continue to climb, power delivered by the battery will drop somewhat
 - The wheels will turn at half the rate and therefore half the power, but the vehicle will continue to climb, power delivered by the battery will drop somewhat
 - The wheels will turn in the opposite direction, moving the vehicle back down the ramp, backdriving the gear train, delivering power back to the voltage supply
 - The wheels will turn in the opposite direction, moving the vehicle back down the ramp, backdriving the gear train, and power delivered by the voltage supply will increase

5. (20pts total) This question and its several parts (a-e) are based on the line drawing of the part below.

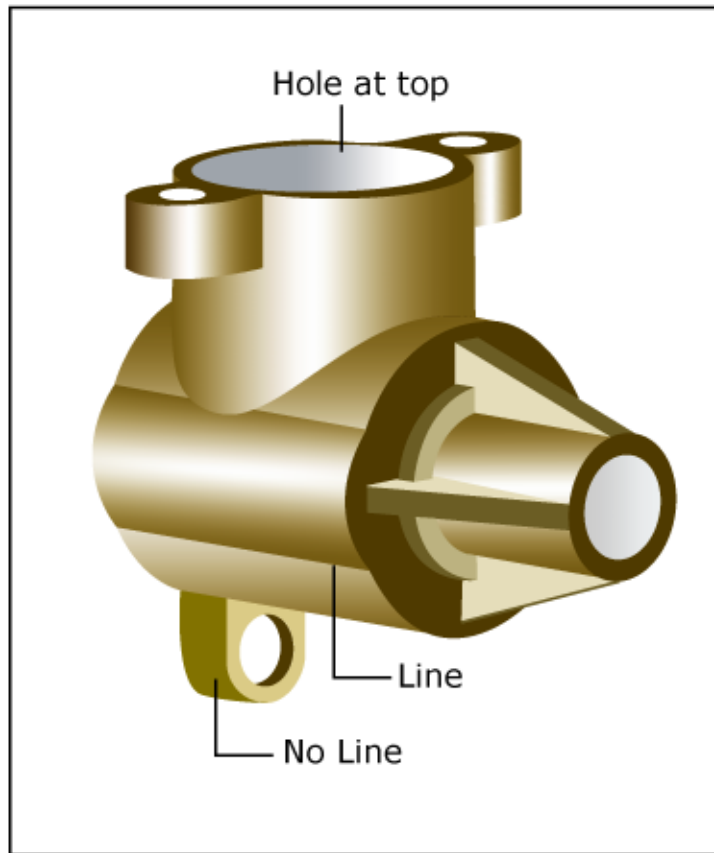
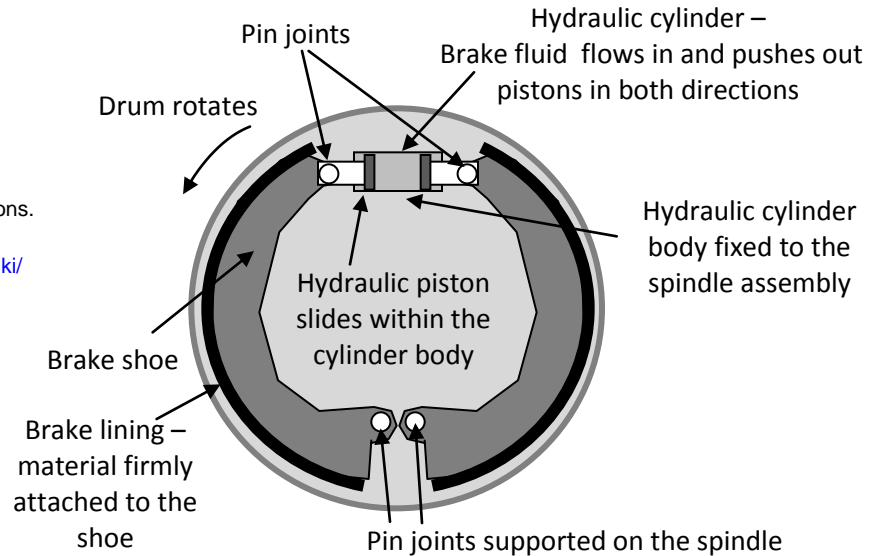

Figure by MIT OpenCourseWare.

- (2pts) Which features of this part might be described as a “rib”? Annotate the drawing above.
- (2pts) What term would you use to describe the circular feature extending from the left side of the part?
- (2pts) If you were to add hidden lines to this drawing, how would the hole on the top of this drawing manifest itself in the rest of the drawing below the hole? Add a sketch of the lines onto the drawing above. Explain any assumptions you needed to make about the geometry of the part not visible in the drawing.
- (4pts) Explain briefly why it is appropriate to show a line on this drawing at the location indicated above by “Line” and not to show a line at the location indicated above by “No Line”.
- (10pts) Sketch front and side views of the part by hand below. Don’t include hidden lines. Do retain the proportions approximately correct and align the two views with one another.

6. (25 points total) The brakes on passenger automobiles are often “drum” brakes operated by a hydraulic system. A real drum brake and a simplified schematic are shown below.

Image removed due to copyright restrictions.
Please see any photo of a drum brake,
such as [http://commons.wikimedia.org/wiki/
File:Trabant_601_duplex_brake.jpg](http://commons.wikimedia.org/wiki/File:Trabant_601_duplex_brake.jpg)



- (5 points) Analyze the kinematic degrees of freedom of the mechanism. To keep things simple, just consider the mechanism comprised of the left brake shoe and the piston attached to it and the related pin joints. How many degrees of freedom does this mechanism have?
- (10 points) Draw a free body diagram of the left shoe assuming the hydraulic cylinder is applying a force F sufficient to displace the shoe outboard to contact the drum. The drum is rotating and is in contact with the shoe, so frictional forces or tractions should be included on your diagram.
- (5 points) Estimate the torque applied to the drum by the left shoe if the force applied by the hydraulic piston on the left shoe is 100N. The drum is rotating and has a coefficient of kinetic friction with the brake lining of $\mu=0.5$.
- (5 points) Imagine that, subsequent to initiating braking, the brake fluid pressure suddenly drops to zero. Estimate the torque applied (if any) to the drum by the left shoe in this circumstance.

7. (25 pts total) Make an isometric sketch of a two-bolt flange based on the three views shown here.

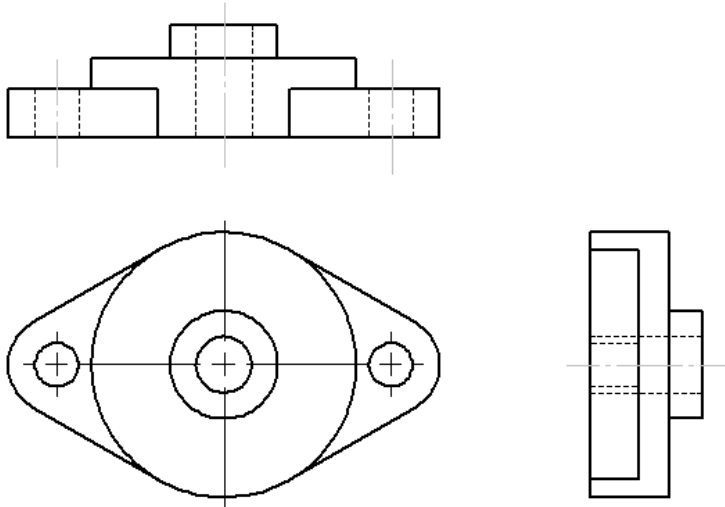

Part geometry from SolidWorks, Inc.