

Application Note AN-3001

Optocoupler Input Drive Circuits

An optocoupler is a combination of a light source and a photosensitive detector. In the optocoupler, or photon coupled pair, the coupling is achieved by light being generated on one side of a transparent insulating gap and being detected on the other side of the gap without an electrical connection between the two sides (except for a minor amount of coupling capacitance). In the Fairchild Semiconductor optocouplers, the light is generated by an infrared light emitting diode, and the photo-detector is a silicon diode which drives an amplifier, e.g., transistor. The sensitivity of the silicon material peaks at the wavelength emitted by the LED, giving maximum signal coupling.

Where the input to the optocoupler is a LED, the input characteristics will be the same, independent of the type of detector employed. The LED diode characteristics are shown in Figure 1. The forward bias current threshold is shown at approximately 1 volt, and the current increases exponentially, the useful range of I_F between 1 mA and 100 mA being delivered at a V_F between 1.2 and 1.3 volts. The dynamic values of the forward bias impedance are current dependent and are shown on the insert graph for R_{DF} and ΔR as defined in the figure. Reverse leakage is in the nano-ampere range before avalanche breakdown.

The LED equivalent circuit is represented in Figure 2, along with typical values of the components. The diode equations are provided if needed for computer modeling and the constants of the equations are given for the IR LED's. Note that the junction capacitance is large and increases with applied forward voltage. An actual plot of this capacitance variation with applied voltage is shown on the graph of Figure 3. It is this large capacitance controlled by the driver impedance which influences the pulse response of the LED. The capacitance must be charged before there is junction current to create light emission. This effect causes an inherent delay of 10-20 nanoseconds or more between applied current and light emission in fast pulse conditions.

The LED is used in the forward biased mode. Since the current increases very rapidly above threshold, the device should always be driven in a current mode, not voltage driven. The simplest method of achieving the current drive is to provide a series current-limiting resistor, as shown in Figure 4, such that the difference between V_{APP} and V_F is

dropped across the resistor at the desired I_F , determined from other criteria. A silicon diode is shown installed inversely parallel to the LED. This diode is used to protect the reverse breakdown of the LED and is the simplest method of achieving this protection. The LED must be protected from excessive power dissipation in the reverse avalanche region. A small amount of reverse current will not harm the LED, but it must be guarded against unexpected current surges.

The forward voltage of the LED has a negative temperature coefficient of 1.05 mV/°C and the variation is shown in Figure 5.

The brightness of the IR LED slowly decreases in an exponential fashion as a function of forward current (I_F) and time. The amount of light degradation is graphed in Figure 6 which is based on experimental data out to 20,000 hours. A 50% degradation is considered to be the failure point. This degradation must be considered in the initial design of optoisolator circuits to allow for the decrease and still remain within design specifications on the current-transfer-ratio (CTR) over the design lifetime of the equipment. Also, a limitation on I_F drive is shown to extend useful lifetime of the device.

In some circumstances it is desirable to have a definite threshold for the LED above the normal 1.1 volts of the diode V_F . This threshold adjustment can be obtained by shunting the LED by a resistor, the value of which is determined by a ratio between the applied voltage, the series resistor, and the desired threshold. The circuit of Figure 7 shows the relationship between these values. The calculations will determine the resistor values required for a given I_{FT} and V_A . It is also quite proper to connect several LED's in series to share the same I_F . The V_F of the series is the sum of the individual V_F 's. Zener diodes may also be used in series.

Where the input applied voltage is reversible or alternating and it is desired to detect the phase or polarity of the input, the bipolar input circuit of Figure 8 can be employed. The individual optocouplers could control different functions or be paralleled to become polarity independent. Note that in this connection, the LED's protect each other in reverse bias.

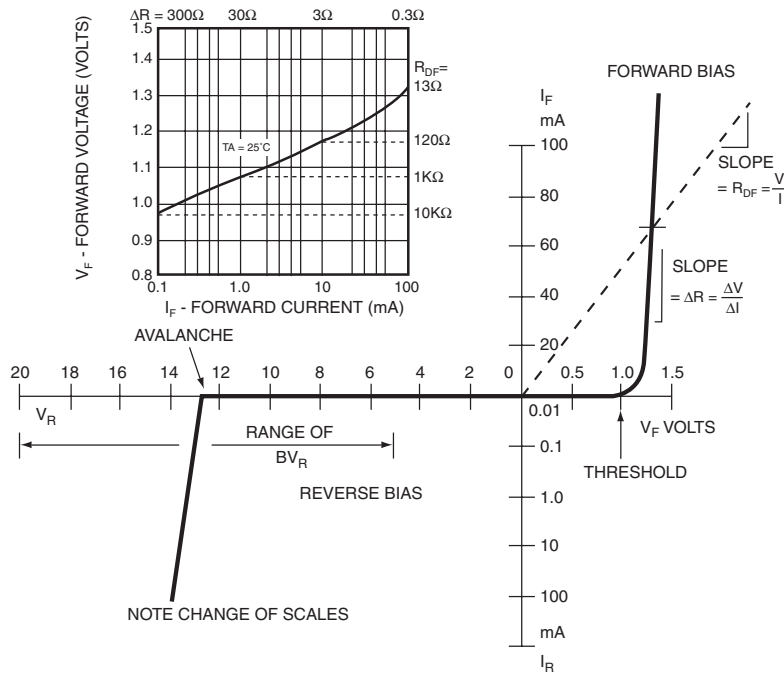
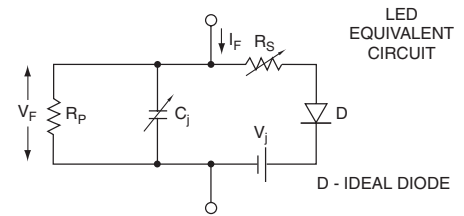

Figure 1. Characteristics of IR LED



V_F	-5	0	-	-	-	V
I_F	-	-	1	10	100	mA
C_j	55	100	300	500	-	pF
V_j		1.0	1.1	1.2	1.3	V
I_R	<10	0	-	-	-	nA
R_S	∞	30	3	0.3		Ω
R_P	$>10^9$	-	-	-	-	Ω

$$I_F = I_{FT} \exp \frac{V_F - V_{FT}}{k}$$

$$V_F = V_{FT} + k \log \frac{I_F}{I_{FT}}$$

For IRLED (940nm)

$$V_{FTH} = 0.98V$$

$$I_{FTH} = 0.10mA$$

$$K = 0.360$$

$$R_S = \frac{0.03V}{I_F (A)}$$

Figure 2. Equivalent Circuit Equations

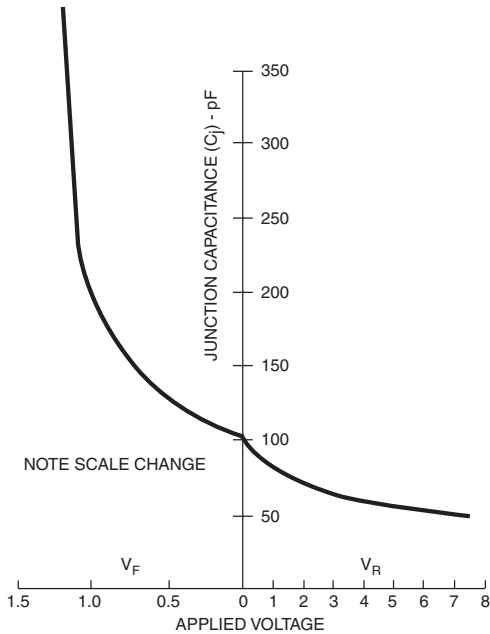

Figure 3. Voltage Dependence of Junction Capacitance

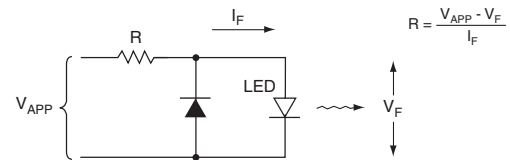

Figure 4. Typical LED Drive Circuit

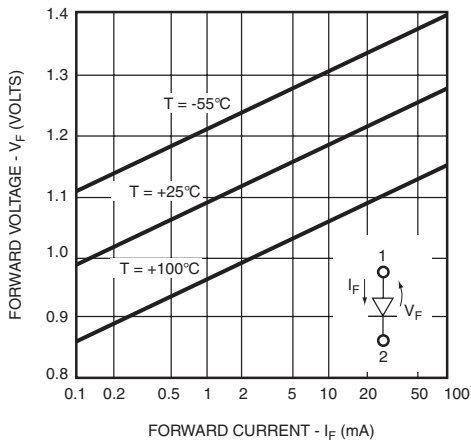

Figure 5. IR Forward Voltage vs. Forward Current and Temperature

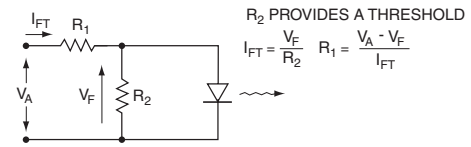

Figure 7. LED Threshold Adjustment

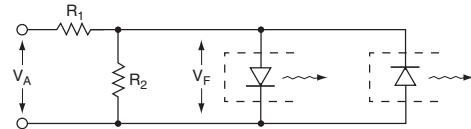

Figure 8. Bipolar Input Selects LED

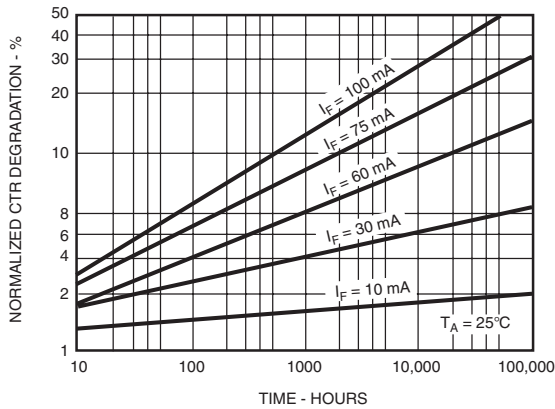

Figure 6. Brightness Degredation vs. Forward Current and Time

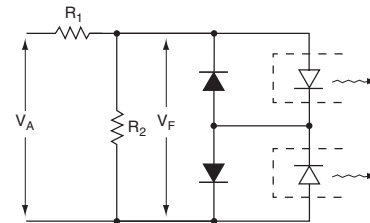

Figure 9. High Threshold Bipolar Input

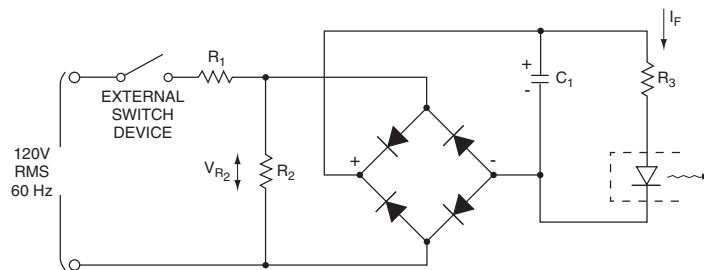

Figure 10. AC Input to LED Drive Circuit

Another method of obtaining a high threshold for high level noise immunity is shown in Figure 9, where the LED's are in inverse series with inverse parallel diodes to conduct the opposite polarity currents. In this circuit, the V_F is the total

forward drop of the LED and silicon diode in series. The resistors serve their normal threshold and current limiting functions. The silicon diodes could be replaced by LED's from other optocouplers or visible signal indicators.

AC Mains Monitoring

In some situations it may be necessary to drive the LED from a 120 VRMS, 60 Hz or 400 Hz source. Since the LED responds in nanoseconds, it will follow the AC excursions faithfully, turning on and off at each zero-crossing of the input. If a constant output is desired from the optocoupler detector as in AC to logic coupling, it is necessary to rectify and filter the input to the LED. The circuit of Figure 10 illustrates a simple filtering scheme to deliver a DC current to the LED. In some cases the filter could be designed into the detector side of the optocoupler, allowing the LED to pulse at line frequency. In the circuit of Figure 10, the value of C_1 is selected to reduce the variations in the I_F between half cycles below the current that is detectable by the detector portion. This condition usually means that the detector is functioning in saturation, so that minor variations of I_F will not be sensed. The values of R_1 , R_2 and R_3 are adjusted to optimize the filtering function, R_3C_1 time constant, etc. Speed of turn-off may be a determining factor. More complicated transistor filtering may be required, such as that shown in Figure 11, where a definite time delay, rise time and fall time can be designed in. In this circuit, C_1 and R_3 serve the same basic function as in Figure 10. The transistor provides a high impedance load to the R_4C_2 filter network, which once reaching the V_F value, suddenly turns on the LED and pulls the transistor quickly into saturation. The turn-off transient consists of the discharge of C_1 , through R_3 and the LED.

Logic to Logic Interface

In logic-to logic coupling using the optocoupler, a simple transistor drive circuit can be used as shown in Figure 12. In the normally-off situation, the LED is energized only when the transistor is in saturation. The design equations are given for calculating the value of the series current limiting resistor. With the transistor off, only minor collector leakage current will flow through the LED. If this small leakage is detectable in the optocoupler detector, the leakage can be bypassed around the LED by the addition of another resistor in parallel with the LED shown as R_1 . The value of R_1 can be large, calculated so that the leakage current develops less than threshold V_F (~0.8 volt) from Figure 5. The drive transistor can be the normal output current sink of a TTL or DTL integrated circuit, which will sink 16 mA at 0.2 volt nominal and up to 50 mA in saturation.

If the logic is not capable of sinking the necessary I_F , an auxiliary drive transistor can be employed to boost current capability. The circuit of Figure 13 shows how a PNP transistor is connected as an emitter follower, or common collector, to obtain current gain. When the output of the gate (G_1) is low, Q_1 is turned on and current flows through the LED. The calculation of R_1 must now include the base-emitter forward biased voltage drop, V_{BE} , as shown in the figure.

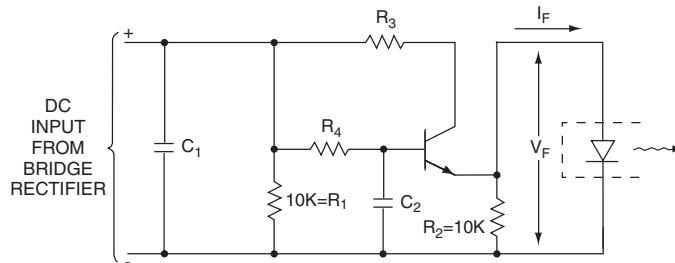

Figure 11. R-C-Transistor Filter Circuit

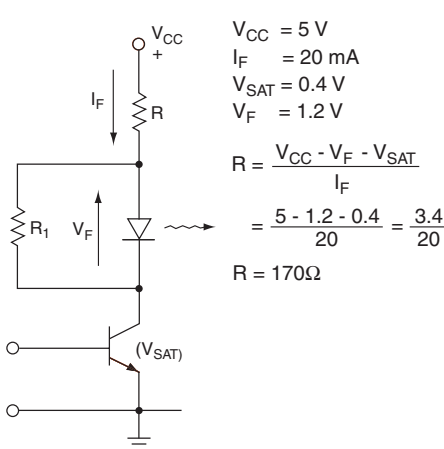

Figure 12. Transistor Drive, Normally Off

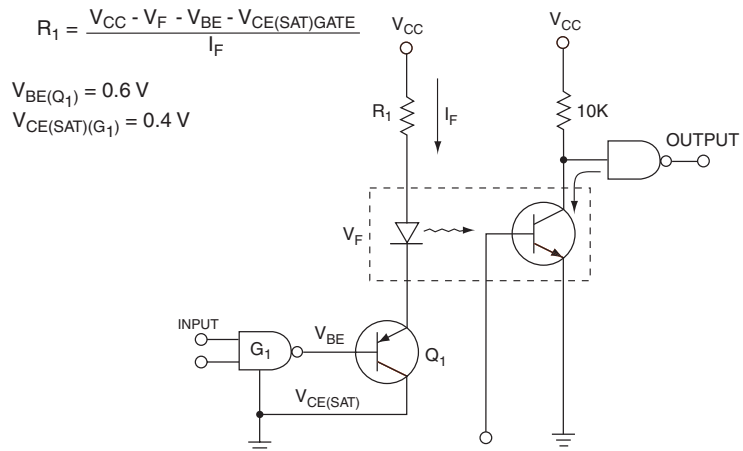

Figure 13. Logic to LED Series Booster

In the normally on situation of Figure 14, the transistor is required to shunt the I_F around the LED, with a V_{SAT} of less than threshold V_F . Typical switching transistors have saturation voltages less than 0.4 volts at $I_C=20$ mA or less. The value of the series resistor is determined to provide the required I_F with the transistor off.

Again, if the logic cannot sink the I_F , a booster transistor can be employed as shown in Figure 15. With the output of the gate low, the transistor Q_1 will be on and the sum of $V_{CE(SAT)}$ of G_1 and V_{BE} of Q_1 , will be less than the threshold V_F of the LED. With the gate high, Q_1 is not conducting and LED is on. The value of R_1 is calculated normally, but shunt current will be greater than I_F . The normally-on or normally-off conditions are selected depending on the required function of the detector portion of the optocoupler and fail-safe operation of the circuits.

In many applications it is found necessary to pulse drive the LED to values beyond the DC ratings of the device. In these

situations a “pulse” is defined as an on-off transient occurring and ending before thermal equilibrium is established between the LED, the lead frame, and the ambient. This equilibrium will normally occur within one millisecond. For a pulse width in the microsecond range, the I_F can be driven above the DC ratings, if the duty cycle is low. The chart of Figure 16 shows the relationship between the amount of overdrive, duty cycle, and pulse width. The overdrive is normalized to the I_{DC} value listed as maximum on the device data sheet. Average power dissipation is the limiting parameter at high duty cycles and short pulse widths. For longer pulse widths, the equilibrium temperature occurs at lower duty cycle values, and peak power is the limiting parameter.

For duty cycles of 1% or less the pulse becomes similar to a nonrecurrent surge allowing additional ratings such as the I^2t used in rectifier diodes. Average current is used for lifetime calculation. The pulse response of the detector must be considered in choosing drive conditions.

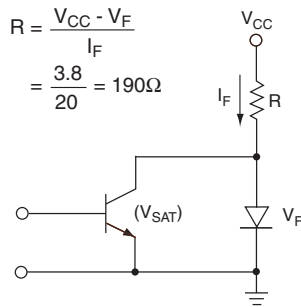

Figure 14. Transistor Drive, Normally On

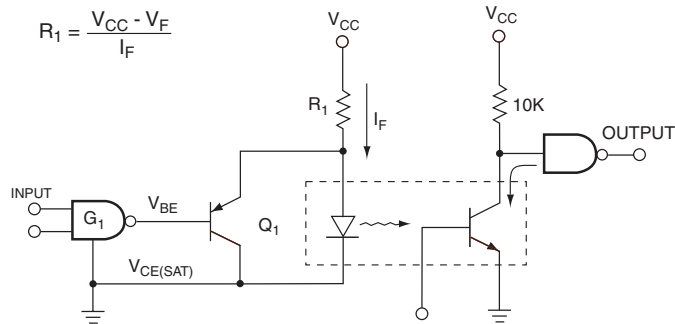

Figure 15. Logic to LED Shunt Booster

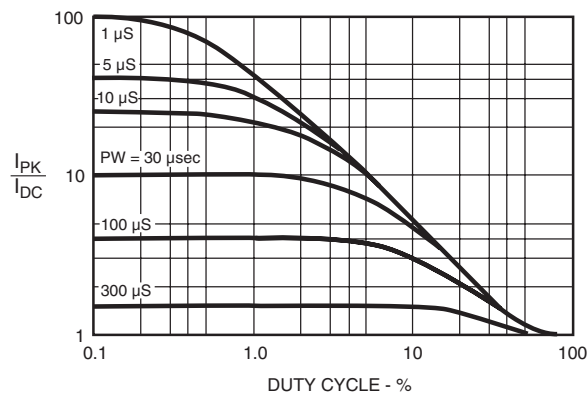

Figure 16. Maximum Peak I_F Pulse Normalized to Max I_{DC} for Pulse Width (PW) and Duty Cycle (%)

LED Current Shunting Techniques

There are situations where it is not desirable to pass all of the input current through the LED. One method to achieve this is to provide a bypass resistor as suggested in Figure 7 for threshold adjustment. This method is satisfactory where the input current is switched on and off completely, but if the information on the current is only a small variation riding on a constant DC level, the bypass resistor also bypasses a large portion of the desired signal around the LED. Two methods can be used to retrieve the signal with little attenuation. If the signal has a rapid variation (e.g., the audio signal on a telephone line), the DC component can be cancelled in the detector by feedback circuits. If the variation is slow, a dynamic shunt can be used instead of the fixed resistor.

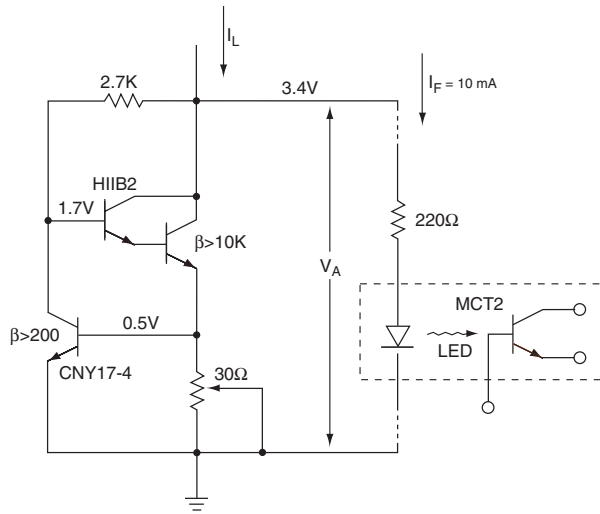

Figure 17. Constant-Current Shunt Impedance

If a constant-current device or circuit is used in parallel with the LED, as shown in Figure 17, the adjusted component of the DC will flow through the dynamic impedance, and any current variations will result in a change of terminal voltage. Therefore, the total current change will flow through the paralleled LED circuit. The graph of Figure 18 shows the performance of this particular circuit adjusted to center on $I_L=120\text{mA}$ and a circuit node voltage of 3.4 volts. In the circuit shown, the detector portions of the CNY17-1 and CNY17-4 were employed for convenience. Note that in Figure 18 most of the current variation occurs as I_F . The ratio between the DC resistance (R_D) and dynamic impedance (R_d) for the shunt is 50, which represents the signal transfer gain achieved over a fixed resistor.

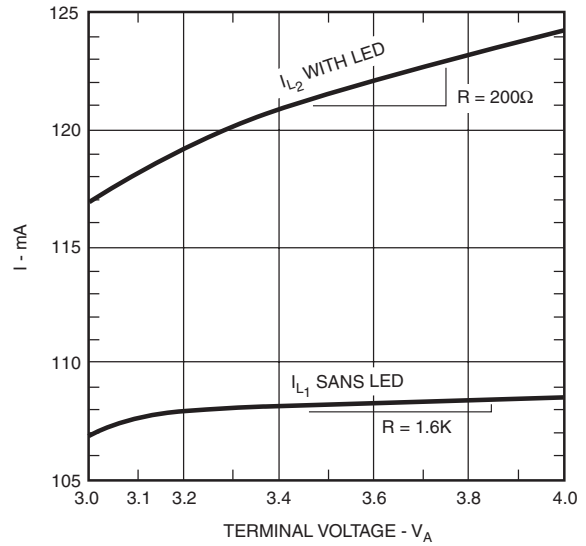

Figure 18. Shunt Impedance Performance

DISCLAIMER

FAIRCHILD SEMICONDUCTOR RESERVES THE RIGHT TO MAKE CHANGES WITHOUT FURTHER NOTICE TO ANY PRODUCTS HEREIN TO IMPROVE RELIABILITY, FUNCTION OR DESIGN. FAIRCHILD DOES NOT ASSUME ANY LIABILITY ARISING OUT OF THE APPLICATION OR USE OF ANY PRODUCT OR CIRCUIT DESCRIBED HEREIN; NEITHER DOES IT CONVEY ANY LICENSE UNDER ITS PATENT RIGHTS, NOR THE RIGHTS OF OTHERS.

LIFE SUPPORT POLICY

FAIRCHILD'S PRODUCTS ARE NOT AUTHORIZED FOR USE AS CRITICAL COMPONENTS IN LIFE SUPPORT DEVICES OR SYSTEMS WITHOUT THE EXPRESS WRITTEN APPROVAL OF THE PRESIDENT OF FAIRCHILD SEMICONDUCTOR CORPORATION. As used herein:

1. Life support devices or systems are devices or systems which, (a) are intended for surgical implant into the body, or (b) support or sustain life, or (c) whose failure to perform when properly used in accordance with instructions for use provided in the labeling, can be reasonably expected to result in significant injury to the user.
2. A critical component is any component of a life support device or system whose failure to perform can be reasonably expected to cause the failure of the life support device or system, or to affect its safety or effectiveness.