

# MANUFACTURING GUIDELINES



## ALIGNMENT JIG FOR LOWER-LIMB PROSTHETICS

### Physical Rehabilitation Programme

Physical Rehabilitation Programme. "Manufacturing Guidelines: Alignment Jig for Lower-Limb Prosthetics." Geneva, Switzerland: International Committee of the Red Cross, 2006. Used with permission.



ICRC



**ICRC**

International Committee of the Red Cross  
19 Avenue de la Paix  
1202 Geneva, Switzerland

[www.icrc.org](http://www.icrc.org)  
© ICRC, September 2006

All photographs: ICRC/PRP

# Table of contents

Foreword	2
Introduction	4
1. Use of the alignment jig	5
1.1 Description of the jig	5
1.2 Possible movements for positioning the positive in space	6
2. Installation of the jig	8
3. Choice and location of centring accessories	9
4. Some examples of use	11
4.1 Trans-tibial sockets	11
4.2 Trans-femoral sockets	13

# Foreword

## The ICRC polypropylene technology

Since its inception in 1979, the ICRC's Physical Rehabilitation Programme has promoted the use of technology that is appropriate to the specific contexts in which the organization operates, i.e., countries affected by war and low-income or developing countries.

The technology must also be tailored to meet the needs of the physically disabled in the countries concerned.

The technology adopted must therefore be:

- durable, comfortable, easy for patients to use and maintain;
- easy for technicians to learn, use and repair;
- standardized but compatible with the climate in different regions of the world;
- low-cost but modern and consistent with internationally accepted standards;
- easily available.

The choice of technology is of great importance for promoting sustainable physical rehabilitation services.

For all these reasons, the ICRC preferred to develop its own technique instead of buying ready-made orthopaedic components, which are generally too expensive and unsuited to the contexts in which the organization works. The cost of the materials used in ICRC prosthetic and orthotic devices is lower than that of the materials used in appliances assembled from commercial ready-made components.

When the ICRC launched its physical rehabilitation programmes back in 1979, locally available materials such as wood, leather and metal were used, and orthopaedic components were manufactured locally. In the early 1990s the ICRC started the process of standardizing the techniques used in its various projects around the world, for the sake of harmonization between the projects, but more importantly to improve the quality of services to patients.

Polypropylene (PP) was introduced into ICRC projects in 1988 for the manufacture of prosthetic sockets. The first polypropylene knee-joint was produced in Cambodia in 1991; other components such as various alignment systems were first developed in Colombia and gradually improved. In parallel, a durable foot, made initially of polypropylene and EthylVinylAcetate (EVA), and now of polypropylene and polyurethane, replaced the traditional wooden/rubber foot.

In 1998, after careful consideration, it was decided to scale down local component production in order to focus on patient care and training of personnel at country level.

## Objective of the manuals

The ICRC's "Manufacturing Guidelines" are designed to provide the information necessary for production of high-quality assistive devices.

The main aims of these informative manuals are as follows:

- To promote and enhance standardization of ICRC polypropylene technology;
- To provide support for training in the use of this technology;
- To promote good practice.

This is another step forward in the effort to ensure that patients have access to high-quality services.

ICRC  
Assistance Division/Health Unit  
Physical Rehabilitation Programme

# Introduction

Every manufacturing technique has its own specific requirements. The technique based on the use of polypropylene which has been developed by the ICRC's physical rehabilitation programme is also subject to this rule; it must combine quality, ease of use and low cost.

The components for trans-tibial (TT) and trans-femoral (TF) prostheses produced by CR Equipements SA (CRE) allow for certain angular and translation adjustments, but these possibilities are limited:

- 20 mm in translation or sliding (2 x 10 mm each side from the neutral point)
- 20 degrees in tilting (2 x 10° on each side of the median axis).

It is advisable to retain these adjustment possibilities for dynamic alignment, and to take into account the fact that static alignment follows the weight-bearing reference lines to achieve a neutral position.

In most of the techniques used for socket manufacture with polypropylene, the connection component, called the cup, is included in the socket during the thermoforming phase. It is the link that holds the other parts of the prosthesis together. Using this technique means that the alignment must be adjusted BEFORE the socket thermoforming process.

Another technique allows the production of "full-contact" sockets. Faulty positioning of the connecting component (the socket cup) during welding makes alignment difficult or impossible to achieve.

Particular attention must therefore be paid to whether the connecting cup or socket cup is placed on the positive before or after the thermoforming phase.

A special tool has been designed and manufactured by the ICRC and CRE to help prosthetic and orthotic (P&O) technicians complete these alignment phases easily and with the required precision.

This tool is the alignment jig.

## **Objective of this document**

The purpose of this document is to demonstrate the relevance and usefulness of the alignment jig for obtaining high-quality results.

The alignment principles applied are based on international P&O standards.

## **Remark**

This document is not a technical manual on the manufacture of TT and TF prostheses.

**1****USE OF THE ALIGNMENT JIG****1.1 Description of the jig**

The alignment jig is a stainless steel frame about 2 metres high and 0.8 metres wide. It is sturdy and stable.

- ▼ The purpose of the jig is to facilitate the positioning in space of the positive plaster, and to hold the connection cup (or socket cup) firmly and precisely during the operation to fix it to the rectified positive with plaster (or by welding).



**Positioning phase**



Obviously, this fixation phase is independent of the type of socket used: the illustration shows TT prostheses with and without soft socket.

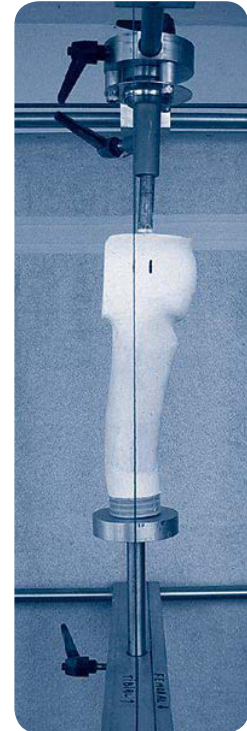

**Fixation phase**

- ▶ In the centre of the jig there are two components which allow the positioning in space and immobilization of the plaster positive in relation to the position of the connection cup.

At the top: the ball and socket joint. This allows:

- suspension and immobilization of the positive;
- rotation around the pipe axis;
- forward, backward and lateral movements.

Below: the tray. This immobilizes the connecting part (cup or socket cup).

The height of the tray is adjustable. It is fixed on a vertical axis, which represents the leg part of the future prosthesis.

To help the technician visualize the component parts of the future prosthesis, a prosthetic foot is fixed to the lower end of this axis.

The alignment principles are independent of height.

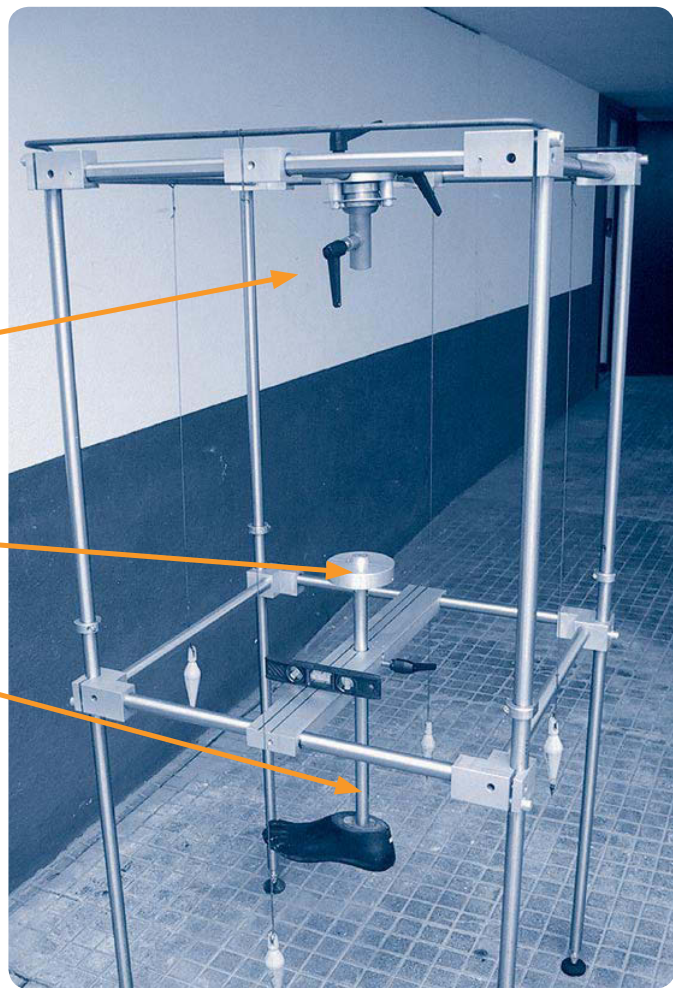

## 1.2 Possible movements for positioning the positive in space

- ▶ Longitudinal movements.
- ▶ Lateral movements.
- ▶ Ball and socket rotation.

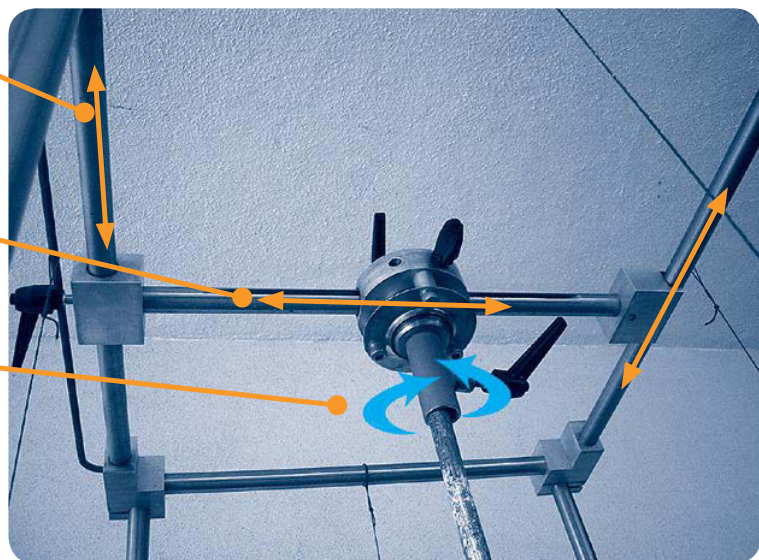



- ▶ Locking of longitudinal movements.
- ▶ Gradient of the pipe. The pipe can describe a cone of about 30° at the summit (about 15° around the vertical line).

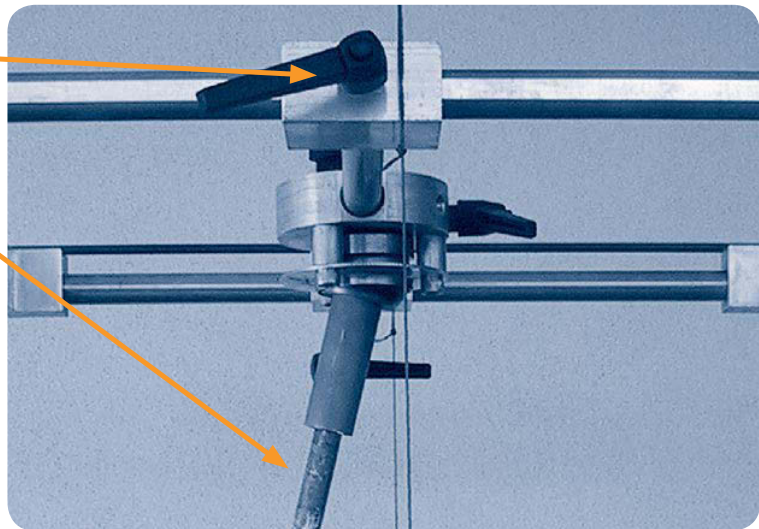

- ▶ The ball and socket allows correct positioning of the positive even when the pipe is wrongly placed.



- ▶ Ball and socket details and blocking screw.

Locking of rotation and gradient of the pipe carrier.

Locking of lateral movements.

Tightening of the pipe.

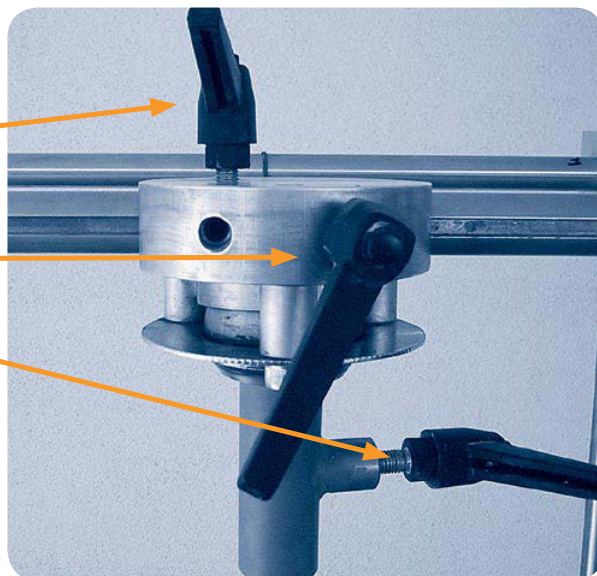

**2****INSTALLATION OF THE JIG**

Two precautions must be taken before starting to use the jig:

- Check with a spirit level that the central beam supporting the vertical axis (which in turn supports the tray) is perfectly horizontal, and make any necessary adjustments by means of the adjustable feet.
- Install plumb lines beyond the range of movements of the pipe carrier.

By establishing frontal and sagittal planes, these plumb lines allow exact application of the principles of alignment.

▶ Frontal and sagittal planes are established with plumb lines (4 x) beyond the movements of the pipe carrier.

▶ Check with a spirit level that the central beam is perfectly horizontal; adjust by means of adjustable feet.

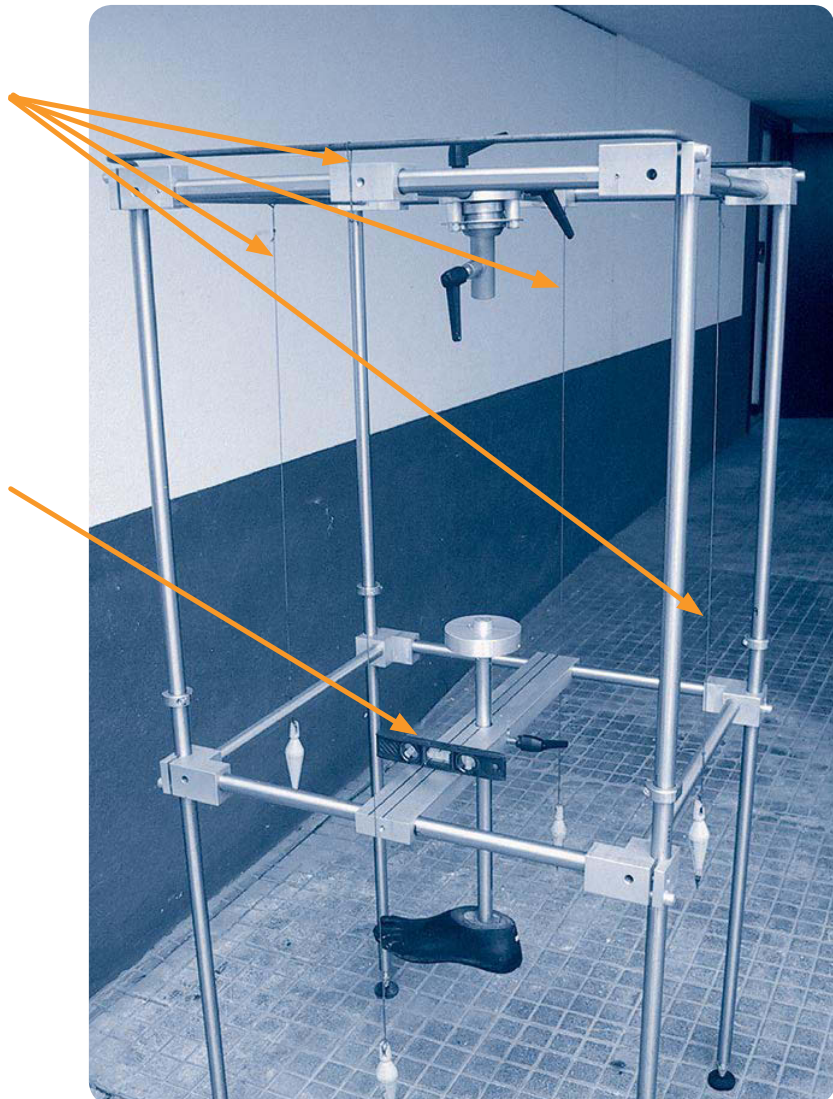

**(A) The tray**

- ▶ The tray has 3 holes  $\text{Ø M 8}$ .

The hole situated 2 cm from the centre is used for adult TF alignment

The central hole is used for adult and child TT.

The hole situated 1 cm from the centre is used for child TF.

When used for adult TF, the positive sagittal plan is perpendicular to the central beam, and when used for child TF, the main line of this beam is the same as the positive sagittal plane.

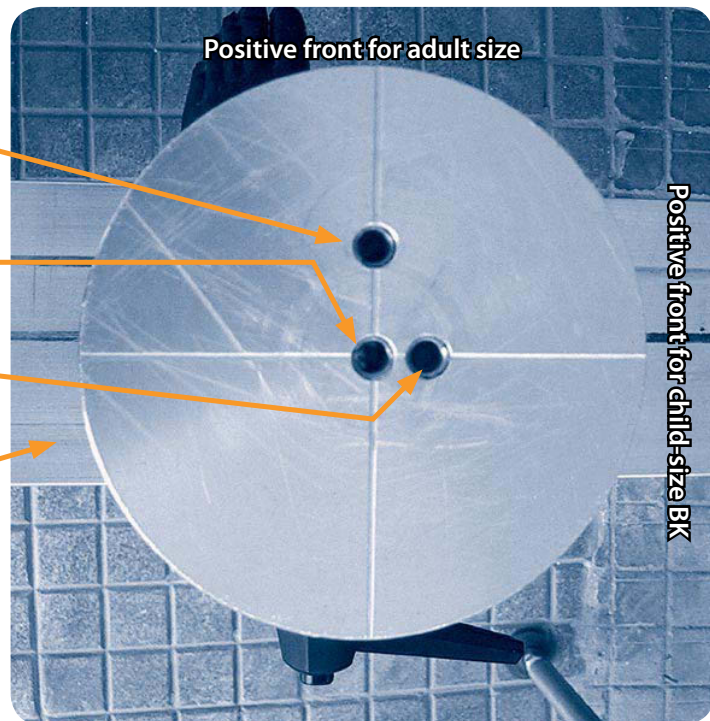
**(B) Production by means of the "cup" (use of the centring cylinder)**

- ▼ Adult and child TT alignment.

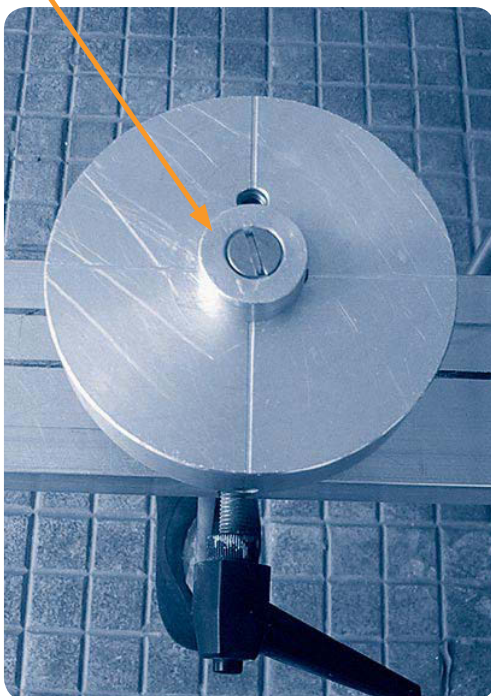

- ▼ Adult TF alignment.

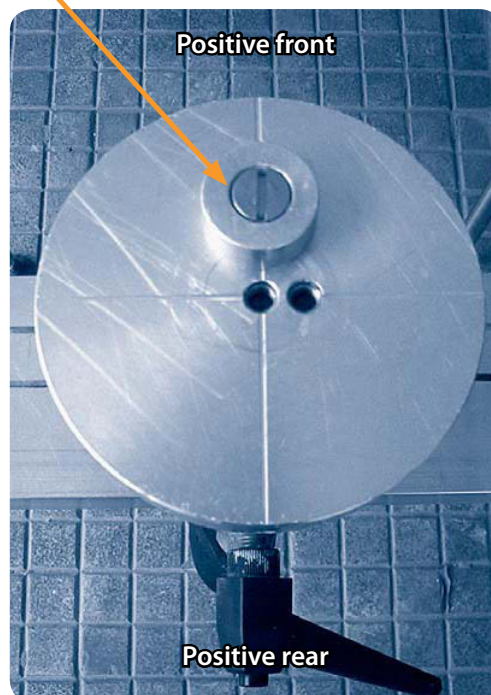

- ▼ TF child-size alignment.

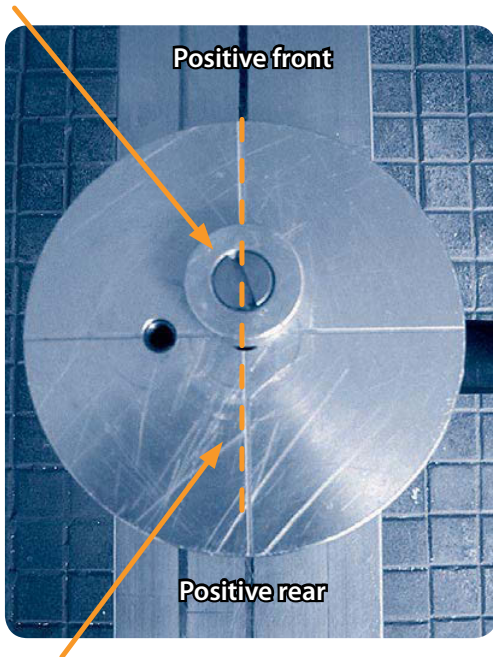

- ▲ Central beam main line.

- ▼ The connecting cup on the tray.

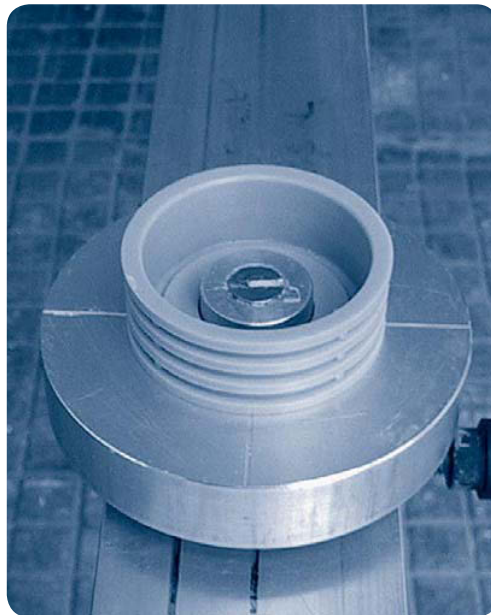

### (C) Production by means of the socket cup

The socket cup makes it possible to manufacture “full-contact sockets” (with contact on the entire surface of the stump, including the extremity).

The principles are the same; only the accessory is different.

- ▼ The accessory for centring the socket cup is positioned for TT in the central hole.

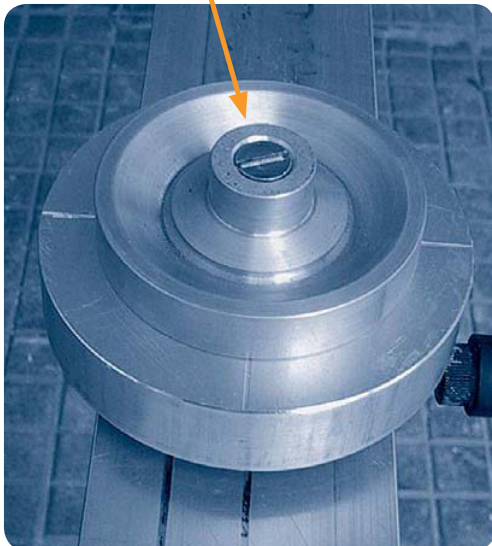

- ▼ The socket cup is positioned for adult TF.

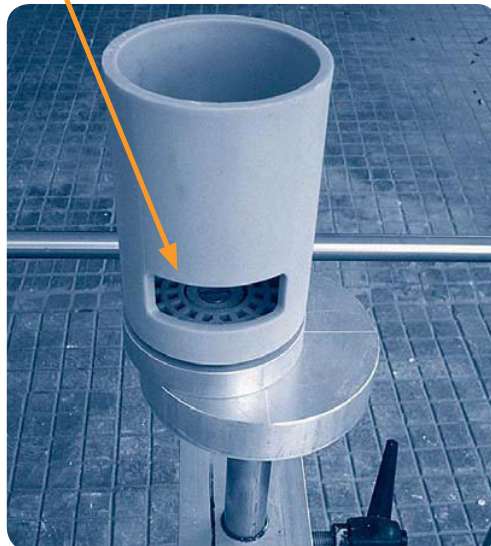

### Sockets without terminal contact

The connection cup is assembled with the positive before the socket thermoforming operation (method most frequently used).

#### 4.1 TT sockets

##### (A) Alignment of a short TT positive (right)

- ▼ Posterior view: The picture is taken of the positive without soft socket to make the shapes and marks of the positive more clearly visible. The presence or absence of a soft socket has no effect on the alignment principles.

View before joining

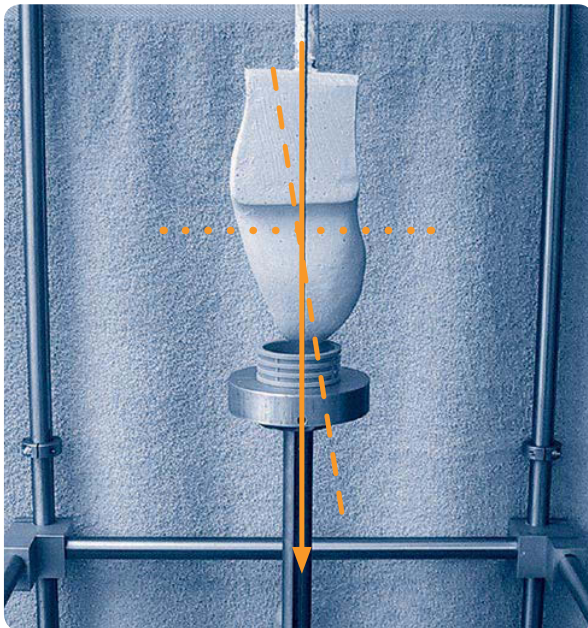

View after joining

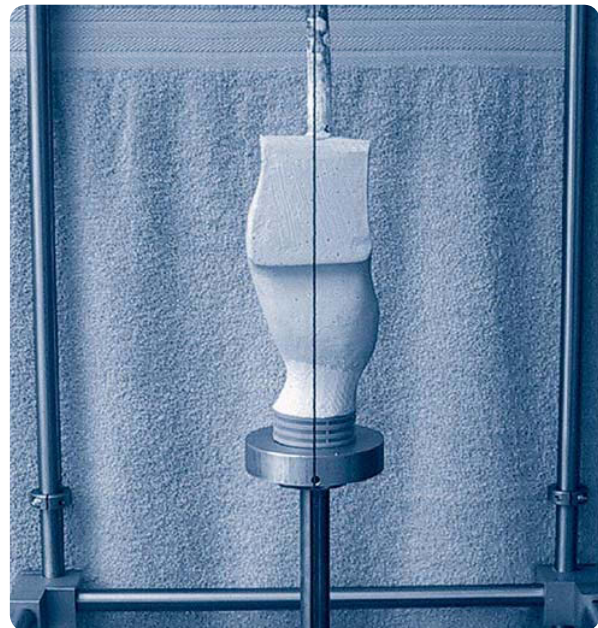

▼ Lateral view:

View before joining

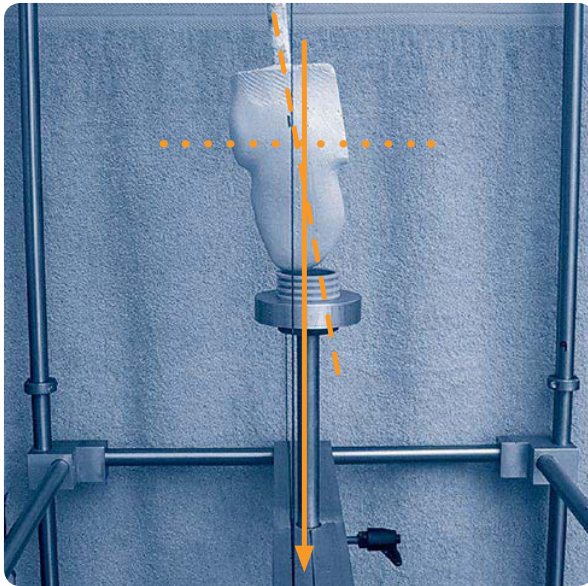

View after joining

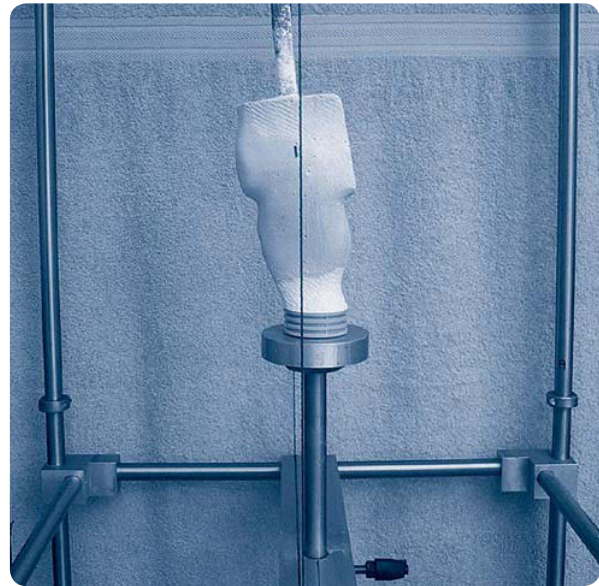

(B) Alignment of a long TT positive (left)

Lateral view before joining

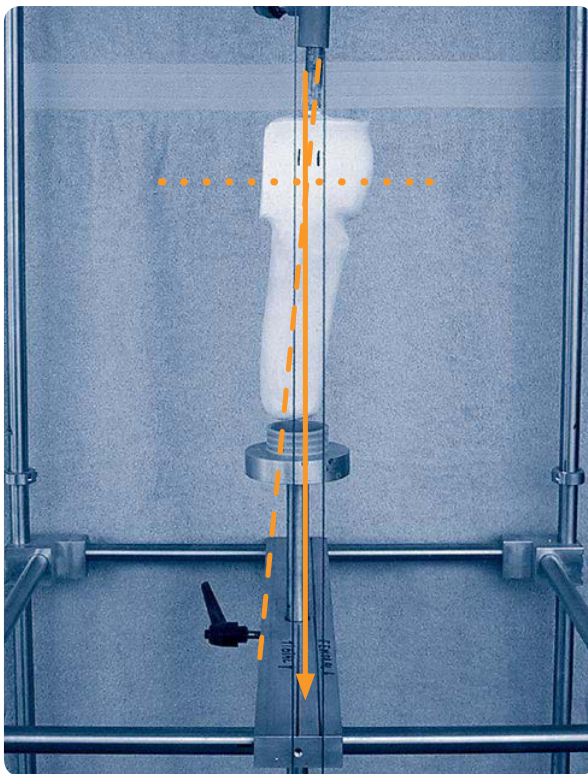

Posterior view before joining

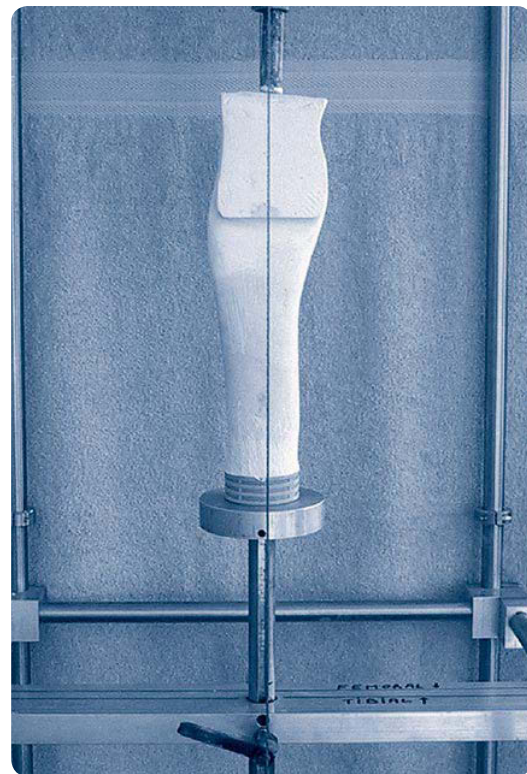

## 4.2 TF sockets

### (A) Parameters to be observed between the CRE knee and the alignment jig

- There is a 2 cm gap between the socket fixation screw and the knee axis to take the flexum into account.

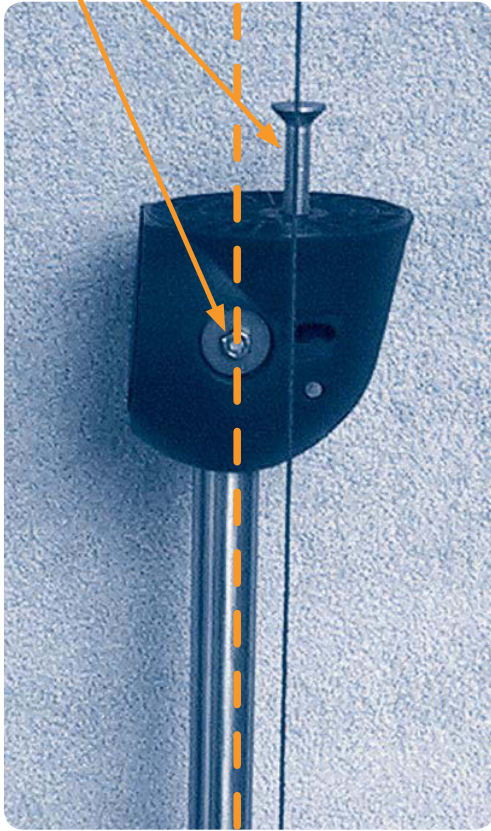

- The knee axis is on the same vertical line as the pipe (the part below the knee).

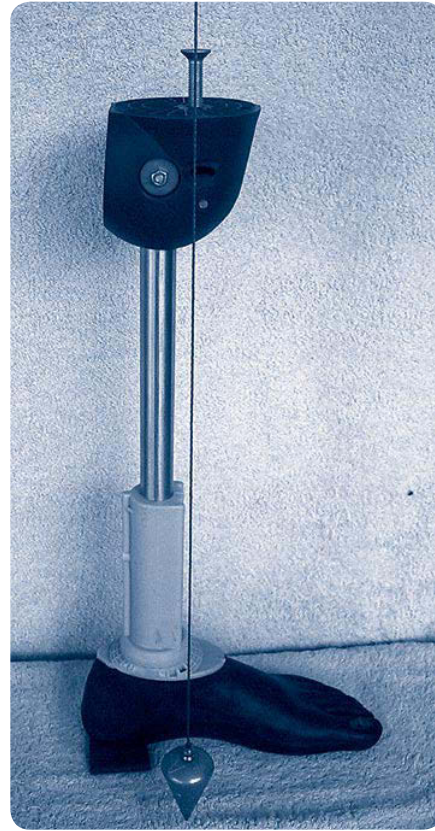

The same positioning features are found on the alignment jig.

Dimensions to be determined:

- a** device for adjusting alignment
- b** distance between upper part of the knee and knee axis

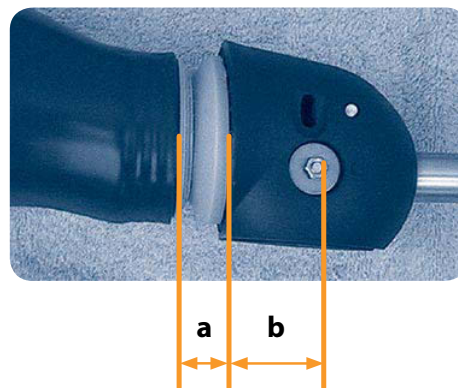

**a** = 22 mm (minimum)

**b** = 40 mm

**(B) Long stumps**

- ▼ It is possible to adjust the distance from ischium to knee when the connection cup is being fixed by calculating height **A** in advance according to the details given above.

Posterior view before joining

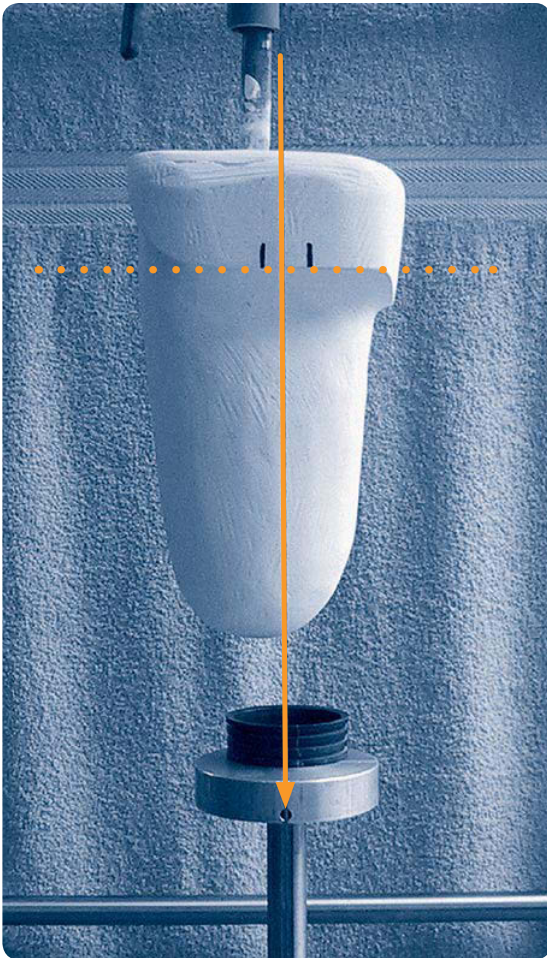

Side view after joining

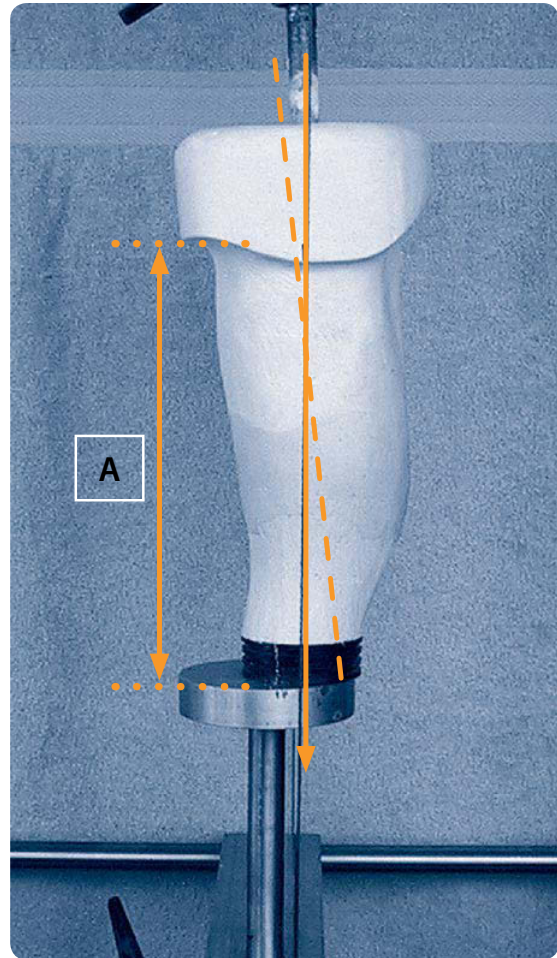



### (C) Short stumps

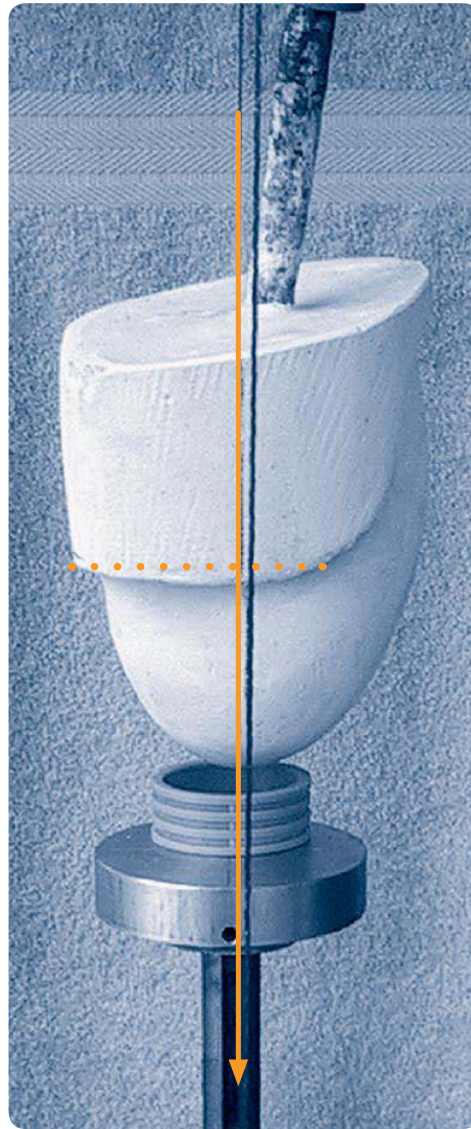
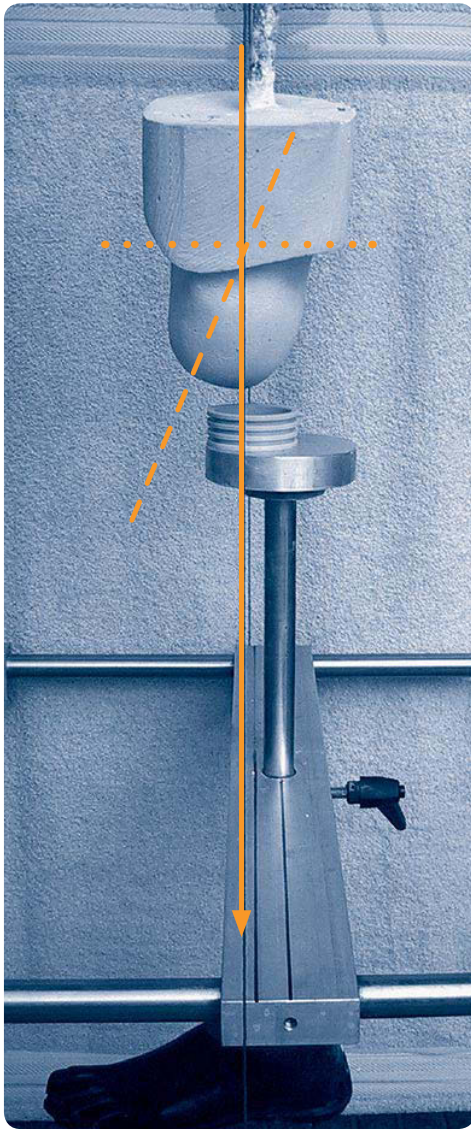

#### “Full-contact” sockets

The connecting element (the socket cup in this case) is assembled with the socket after the thermoforming operation.

**Warning:** Special care must be taken when the socket cup is used as the connecting component with the “contact socket”, for the safety of the patient. Indeed, in order to strengthen the welding between socket and cup after thermoforming, the socket must be carefully adjusted as shown in the illustration above.

Then, to ensure the patient’s safety:

- the welding should be performed with particular care;
- the patient should not be left alone during the fitting and rehabilitation phases;
- polypropylene must be used for finishing so as to form an “exoskeleton” that guarantees the solidity of the prosthesis.

The socket cup is easy to use:

- Align the socket according to the possibilities offered by the jig.
- Install in the tray the centring device designed for socket cups.
- Cut the socket cup at the desired length and give it the appropriate shape.
- Weld the socket cup to the socket lightly with a welding iron.
- Remove the assembly thus obtained.
- End with careful welding.

### (A) TT socket

Short TT socket (side view)

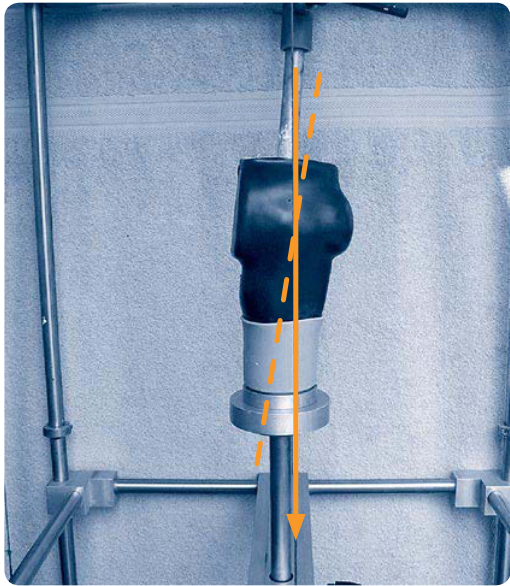

Long TT socket (posterior view)

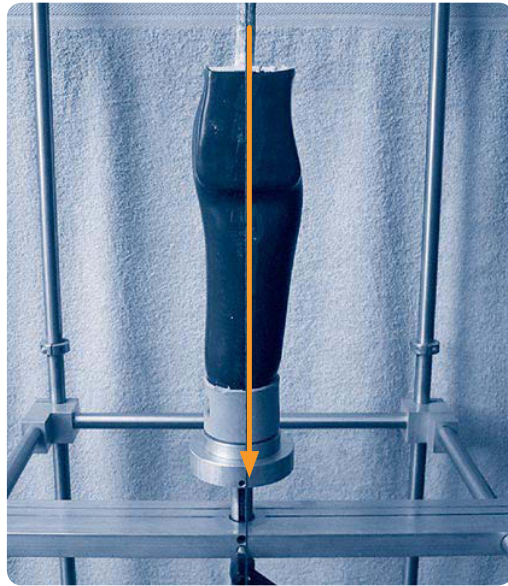

### (B) TF socket

Short TF socket (posterior view)

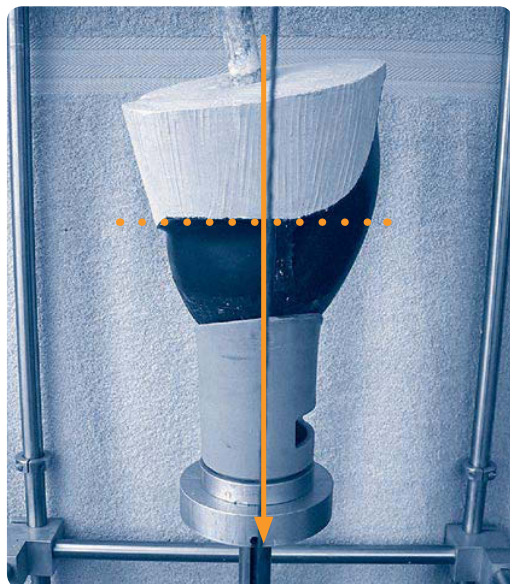

Long TF socket (side view)

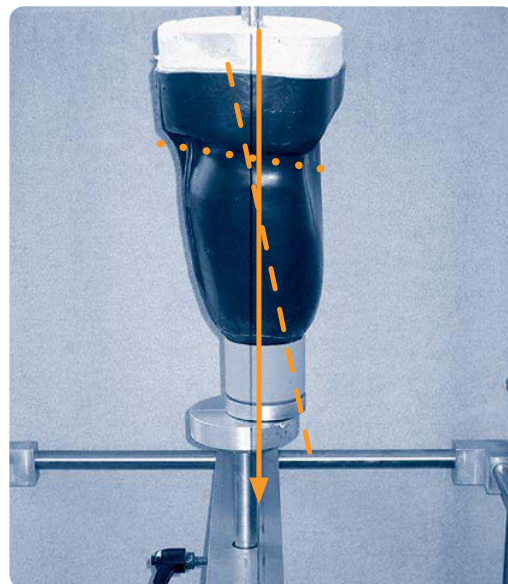

## **MISSION**

The International Committee of the Red Cross (ICRC) is an impartial, neutral and independent organization whose exclusively humanitarian mission is to protect the lives and dignity of victims of war and internal violence and to provide them with assistance. It directs and coordinates the international relief activities conducted by the Movement in situations of conflict. It also endeavours to prevent suffering by promoting and strengthening humanitarian law and universal humanitarian principles. Established in 1863, the ICRC is at the origin of the International Red Cross and Red Crescent Movement.

## **Acknowledgements:**

Jean François Gallay  
Leo Gasser  
Pierre Gauthier  
Frank Joumier  
Jacques Lepetit  
Bernard Matagne  
Joel Nininger  
Guy Nury  
Peter Poetsma  
Hmayak Tarakhchyan

and all prosthetists-orthotists who have worked in ICRC-assisted physical rehabilitation centres.



ICRC

MIT OpenCourseWare  
<http://ocw.mit.edu>

EC.722 Special Topics at Edgerton Center:Developing World Prosthetics  
Spring 2010

For information about citing these materials or our Terms of Use, visit: <http://ocw.mit.edu/terms>.