

MANUFACTURING GUIDELINES



TRANS-FEMORAL PROSTHESIS

Physical Rehabilitation Programme

Physical Rehabilitation Programme. "Manufacturing Guidelines: Trans-Femoral Prosthesis." Geneva, Switzerland: International Committee of the Red Cross, 2006. Used with permission.



ICRC



ICRC

International Committee of the Red Cross
19 Avenue de la Paix
1202 Geneva, Switzerland

www.icrc.org
© ICRC, September 2006

All photographs: ICRC/PRP

Table of contents

Foreword	2
Introduction	4
1. Raw materials and components	4
2. Measurements and socket manufacture	5
2.1 Trans-femoral cup alignment and socket manufacture	6
2.2 Total-contact prosthesis	11
3. Building up the prosthesis and bench alignment	15
4. Polypropylene cosmetic manufacture	28
5. EVA cosmetic manufacture	38
Reference list of materials	41

Foreword

The ICRC polypropylene technology

Since its inception in 1979, the ICRC's Physical Rehabilitation Programme has promoted the use of technology that is appropriate to the specific contexts in which the organization operates, i.e., countries affected by war and low-income or developing countries.

The technology must also be tailored to meet the needs of the physically disabled in the countries concerned.

The technology adopted must therefore be:

- durable, comfortable, easy for patients to use and maintain;
- easy for technicians to learn, use and repair;
- standardized but compatible with the climate in different regions of the world;
- low-cost but modern and consistent with internationally accepted standards;
- easily available.

The choice of technology is of great importance for promoting sustainable physical rehabilitation services.

For all these reasons, the ICRC preferred to develop its own technique instead of buying ready-made orthopaedic components, which are generally too expensive and unsuited to the contexts in which the organization works. The cost of the materials used in ICRC prosthetic and orthotic devices is lower than that of the materials used in appliances assembled from commercial ready-made components.

When the ICRC launched its physical rehabilitation programmes back in 1979, locally available materials such as wood, leather and metal were used, and orthopaedic components were manufactured locally. In the early 1990s the ICRC started the process of standardizing the techniques used in its various projects around the world, for the sake of harmonization between the projects, but more importantly to improve the quality of services to patients.

Polypropylene (PP) was introduced into ICRC projects in 1988 for the manufacture of prosthetic sockets. The first polypropylene knee-joint was produced in Cambodia in 1991; other components such as various alignment systems were first developed in Colombia and gradually improved. In parallel, a durable foot, made initially of polypropylene and EthylVinylAcetate (EVA), and now of polypropylene and polyurethane, replaced the traditional wooden/rubber foot.

In 1998, after careful consideration, it was decided to scale down local component production in order to focus on patient care and training of personnel at country level.

Objective of the manuals

The ICRC's "Manufacturing Guidelines" are designed to provide the information necessary for production of high-quality assistive devices.

The main aims of these informative manuals are as follows:

- To promote and enhance standardization of ICRC polypropylene technology;
- To provide support for training in the use of this technology;
- To promote good practice.

This is another step forward in the effort to ensure that patients have access to high-quality services.

ICRC
Assistance Division/Health Unit
Physical Rehabilitation Programme

Introduction

The aim of this document is to describe a method for manufacturing **trans-femoral (TF) prostheses** using the ICRC's polypropylene technology as applied at the Physical Rehabilitation Centre in Addis Ababa.

The casting, rectification and alignment methods used correspond to international prosthetic and orthotic (P&O) standards of practice and are therefore not described in these ICRC manufacturing guidelines.

1 RAW MATERIALS AND COMPONENTS

Trans-femoral kits are available in adult and child sizes.

▼ Contents of the kit:

- 1 Solid Ankle Cushion Heel (SACH) foot
- 2 Hexagonal-head bolt and lock washer
- 3 Convex ankle
- 4 Concave cylinder and pin
- 5 Set of washers, nut and bolt
- 6 Convex disc
- 7 Conical cup
- 8 Trans-femoral cup
- 9 Knee shell

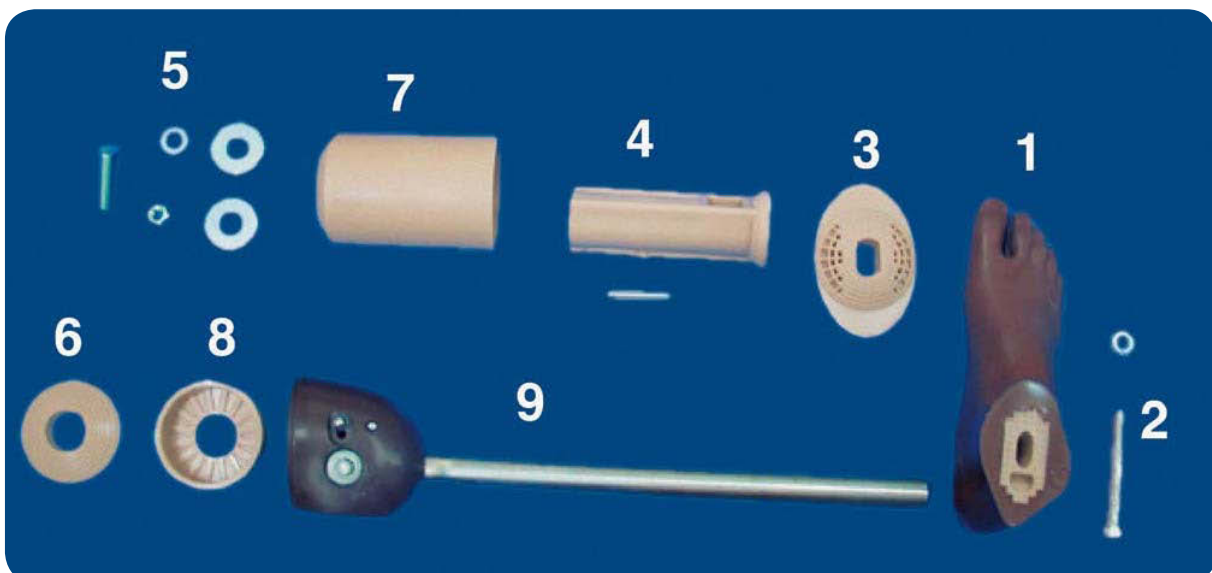

Assessment, measurements and casting

- ▶ The patient is assessed, a prescription is made and measurements are taken in accordance with best P&O practice.



- ▶ A negative cast is taken in accordance with usual P&O practice.



- ▶ The mould is filled to produce the positive, which is rectified according to the measurements taken.



2.1 Trans-femoral cup alignment and socket manufacture

- ▶ Chamfer the edge of the trans-femoral cup.



Alignment of the trans-femoral cup

- ▶ Cover the mould with nylon.

Fix the nail at the bottom of the mould, where the cup will be attached.

Place the TF mould on the CR alignment jig; align according to the instructions on the use of the jig (separate manual). Make the alignment in accordance with the measurement card. Fix the cup to the socket with plaster of Paris (POP).



- ▶ Add a piece of EVA at the distal part of the cup.

This will prevent the PP from being drawn in during suction.

It will also facilitate opening.

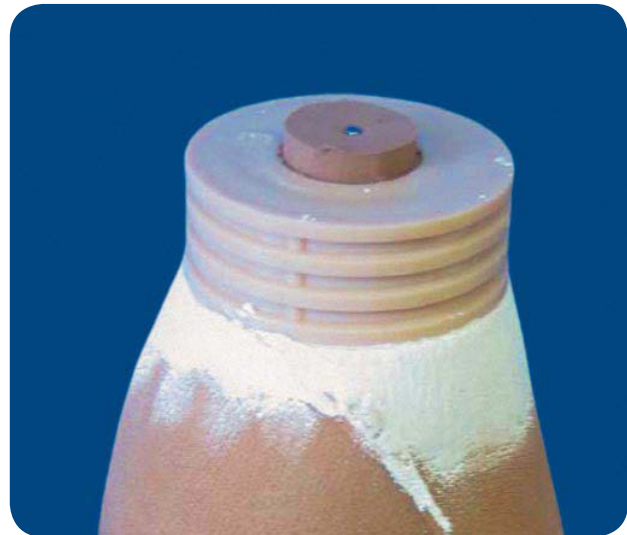

- ▶ Cut a sheet of 5 mm PP according to the measurements (add 5 cm to the circumference and 10-15 cm to the length).

Leave the PP in the oven at around 180° for about 20 minutes.

Drape the PP on the mould and open the vacuum suction.



- ▶ Cut off the excess PP.

Leave the vacuum on until the PP cools down.



- ▶ Wait at least 6 hours before opening.

Draw the trim line on the proximal part of the socket.

Use the oscillating saw to cut the PP.

Remove the plaster.

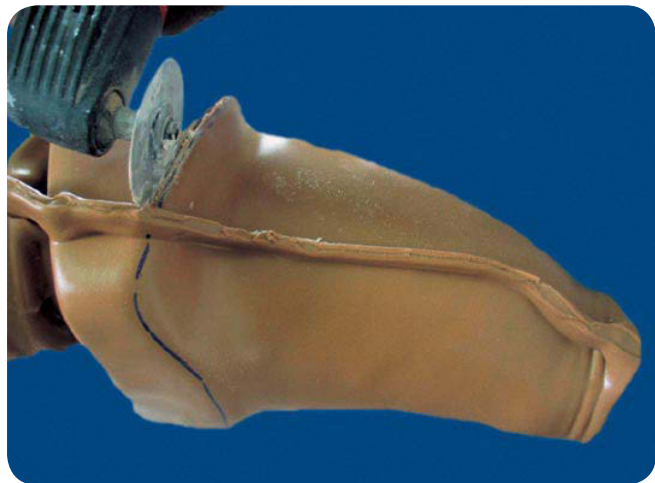

- ▶ Grind the distal part of the cup down to the EVA pad.

Use a screwdriver to remove the EVA.



- ▶ Grind the distal part until it is flat.



- ▶ Grind the distal part until it is flat.
Do not remove all the PP.



- ▶ Check that the surface is flat.



- ▶ Grind the socket along the trim lines with the router.



- ▶ Use a sharp piece of glass to smooth the edge of the socket.



- ▶ Using a conical drill, make the hole for the cotton stocking or for the suction valve.



2.2 Total-contact prosthesis

There are two ways of manufacturing a total-contact trans-femoral socket:

1. By the same procedure as for a conventional TF;
2. By welding the conical cup directly under the PP socket.

- ▼ Position the suction valve medio-laterally and distally to the plaster mould. Use the suction valve ring to shape the plaster. Reduce the diameter of the plaster to allow for the thickness of PP used (4 or 5 mm). Smooth it nicely and break the edge. (see 2.1, page 6).

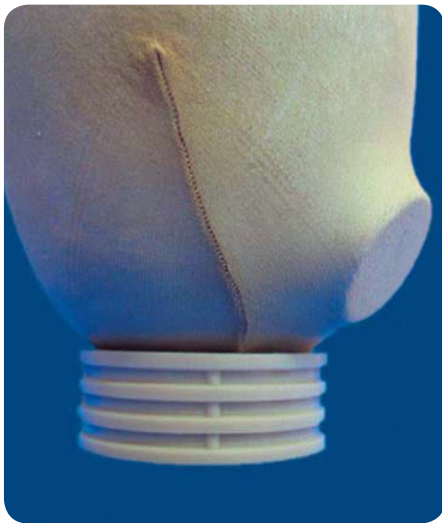

- Cover the mould with a nylon stocking.

Fix the cup with plaster in the usual way.



During the first fitting, glue a piece of EVA inside the cup in order to avoid air leakage.

Glue a 12 mm and a 6 mm piece of EVA inside the cup. Finally, use a 3 mm piece to cover the cup and the sides of the cup.

▼ Material needed for finishing.

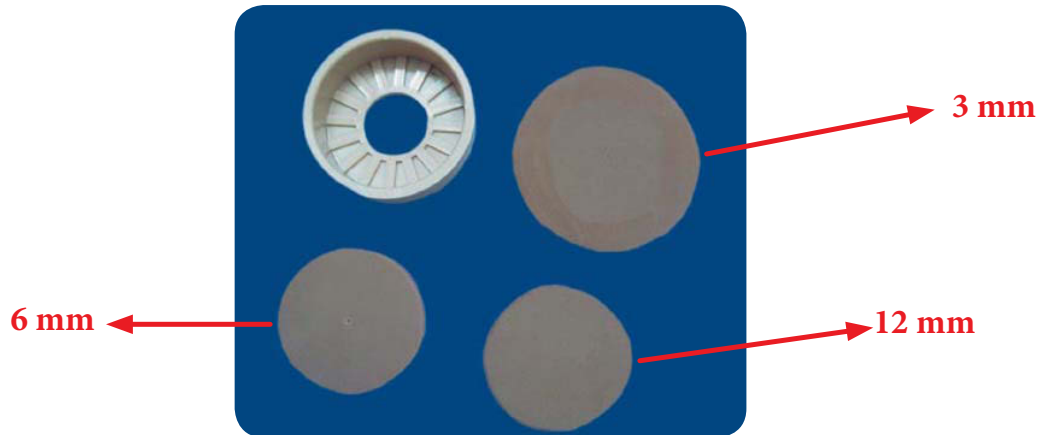

▼ Glue the 12 mm and 6 mm EVA discs inside the cup.

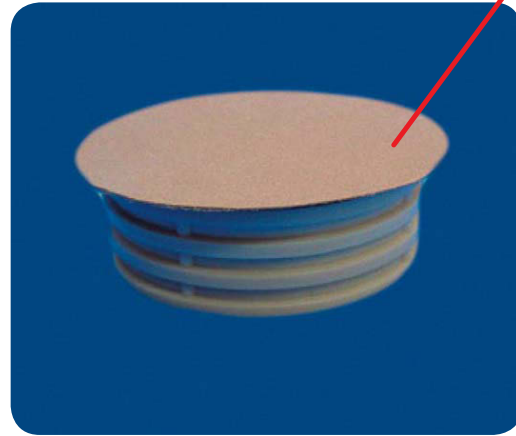

▼ Lastly, glue the 3 mm EVA all around the cup.

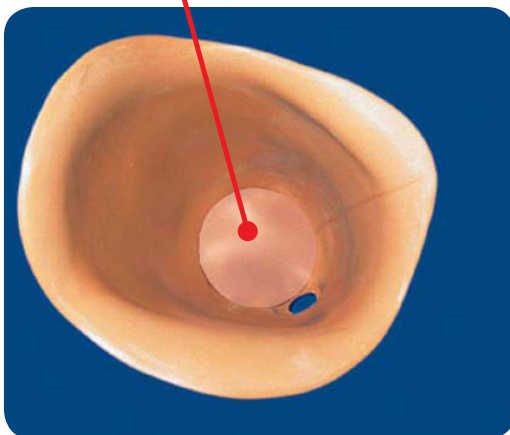

- ▶ Drill a hole according to the diameter of the suction valve.



- ▶ Smooth the edge with a sharp piece of glass.

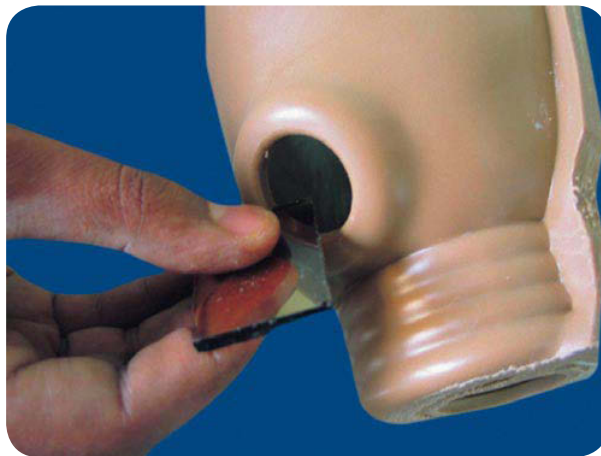

- ▶ Test the suction valve and check by adding water inside the socket.

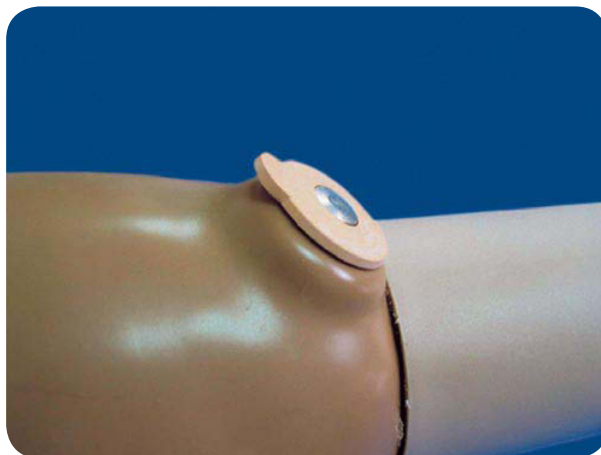

- ▶ If the conical cup is used, it must be adjusted to the socket in accordance with the alignment.

Use the welding iron to make a groove between the socket and the conical cup.

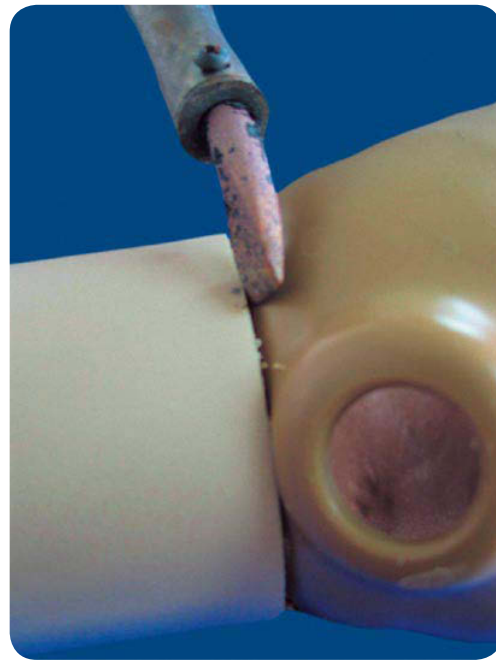

- ▶ Use the hot-air welding gun to weld the cup to the socket.

This has to be done very carefully to avoid breakage during the first fitting.

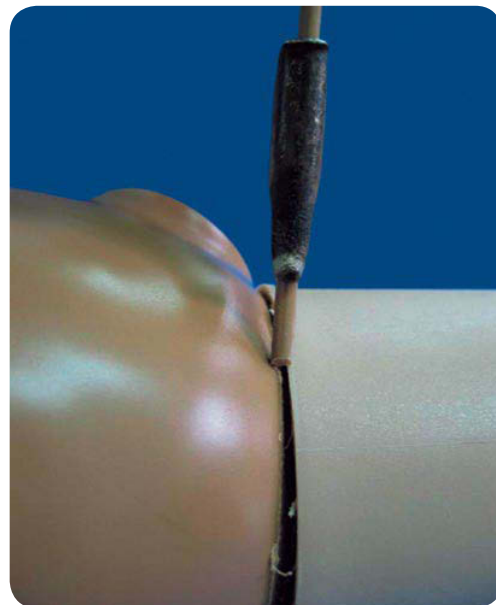

The building-up and bench alignment process – steps to follow

- Ankle-foot alignment
- Socket alignment
- Adjustment of length
- Welding of cylinders
- Alignment of finished prosthesis

Ankle-foot alignment

An extra 4 mm plate must be attached to the convex ankle. (**For 6 mm ankle disc only.**)

Drill two holes as shown on the illustration below and fix the two components together with a PP welding rod. (**For 6 mm ankle disc only.**)

This will prevent breakage of the foot bolt.

▼ Components for 6 mm ankle disc only.

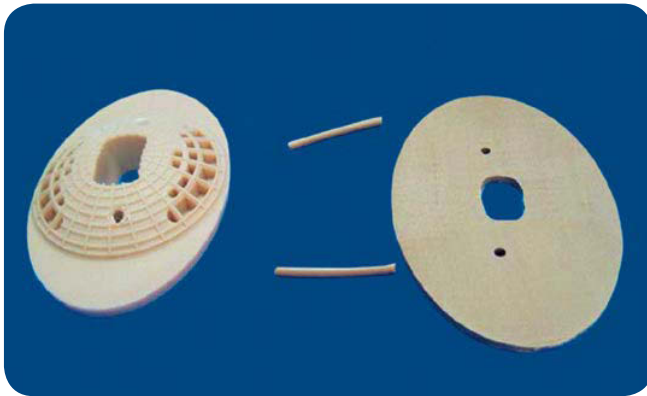

▼ Preparation before fixation for 6 mm ankle disc only.

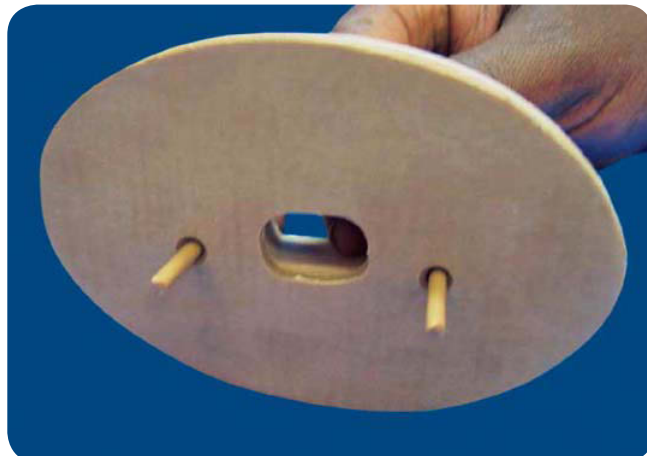
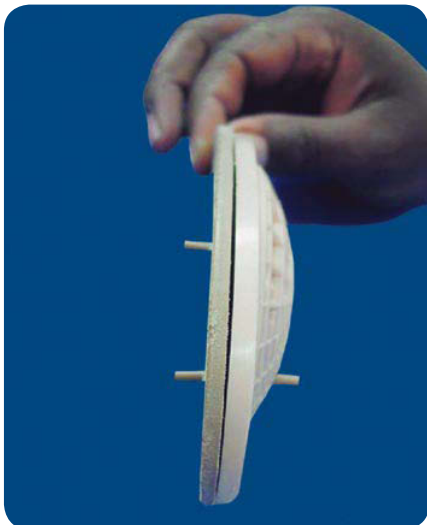

▼ Fixation procedure.

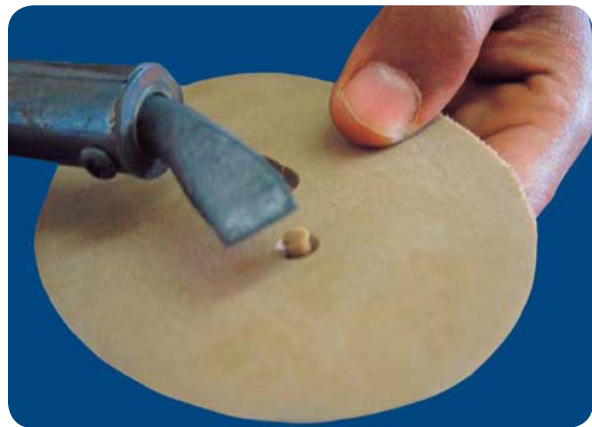
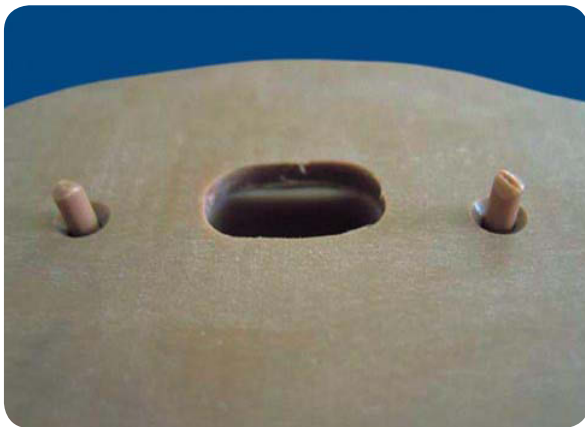
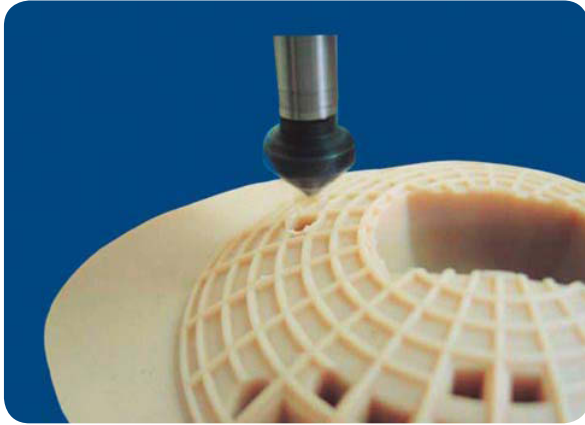

▼ Final result for 6 mm ankle disc only.



▼ For maximum strength of the assembly, the opening of the concave cylinder must be in front, and the reinforcement bar at the back.



The ankle alignment system allows dorsal and plantar flexion, medio-lateral movements so that the prosthesis can be adjusted to the heel height of the shoe.

The alignment can be adjusted for a heel height of between 0 mm and 20 mm, but a heel height of 10 mm is recommended.

The heel height is adjusted according to the patient's shoe; the concave cylinder **must be perpendicular to the ground.**

- ▶ The foot is adjusted in external rotations of 5°.

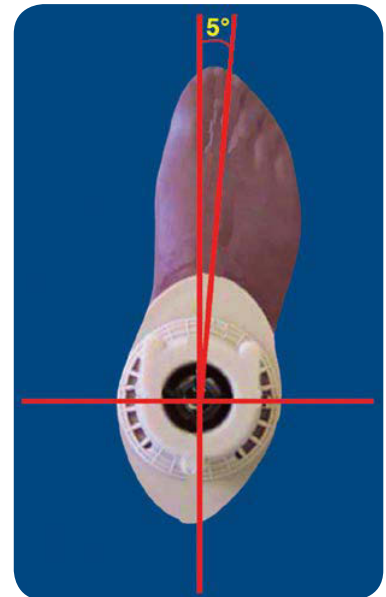
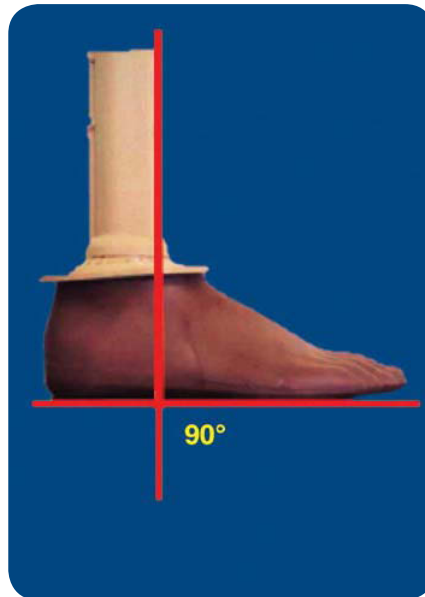

- ▶ Check the alignment once again with the patient's shoe on the foot.



Knee-ankle-foot alignment

- ▼ Same measurement.



- ▶ The measurement taken on the patient must be from the medial tibial plateau plus 1.5 to 2 cm to the ground.

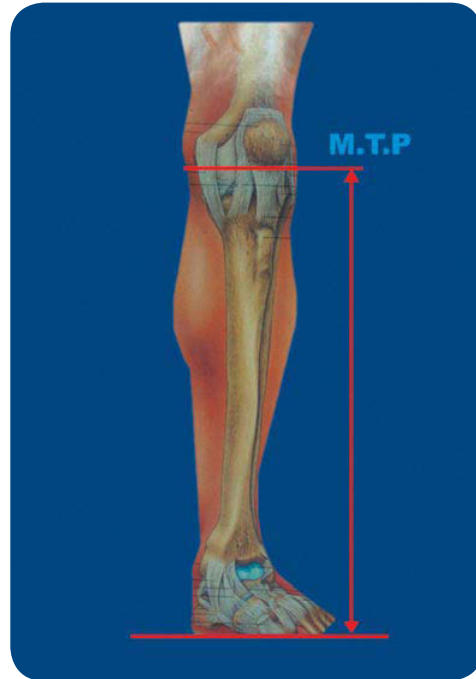

- ▶ Transfer this measurement from the foot up to the mechanical knee-joint axis.

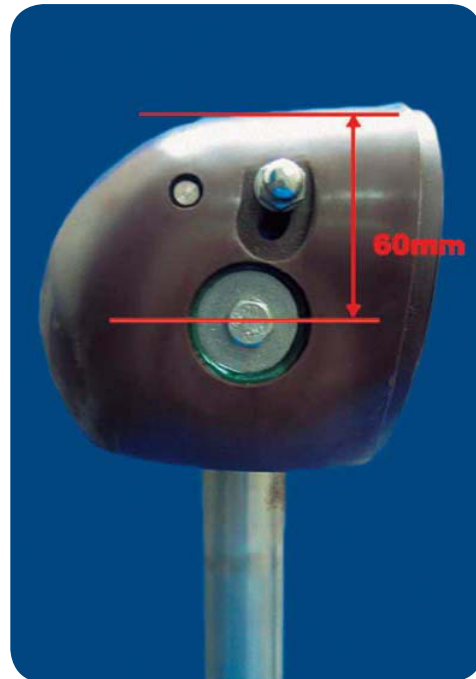

- ▶ Draw a line with a marker according to the measurement taken.

Make another mark 9 cm from the first. This corresponds to the bottom of the concave cylinder minus 1 cm.

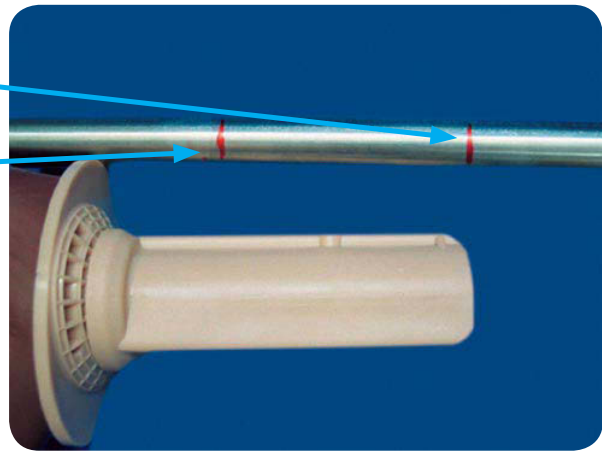

- ▶ Use the pipe cutter to make the cut.

Smooth the edges.



- ▶ Pay special attention to the rotation of the knee-joint with the foot.

Heat the distal part of the pipe with the hot-air welding gun.

Use a rubber mallet to insert the knee-joint into the concave cylinder as far as the mark.



Socket and bench alignment

Length adjustment for normal stump length

The socket is connected to the conical cup (after length adjustment) with a convex disc in between. The conical cup is welded directly on top of the knee joint. The convex disc allows abduction, adduction, flexion, extension and shifting in all directions.

- ▼ Check the alignment and adjust the conical cup according to the measurements taken.

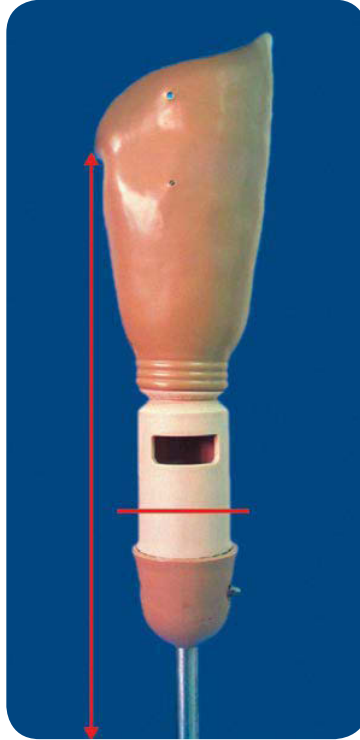
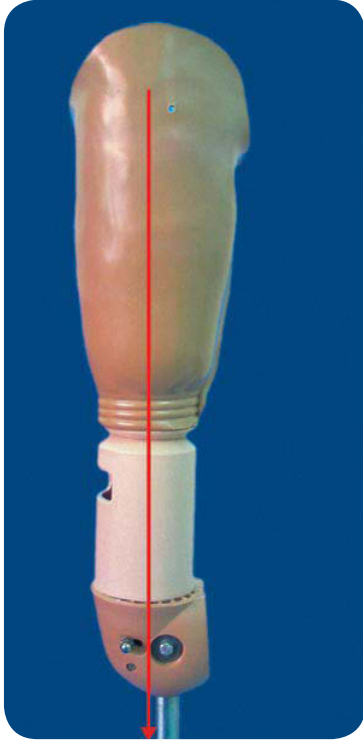

Cup opening in front
CORRECT



Cup opening at back
INCORRECT



- ▼ The force patterns on heel strike are as shown in these illustrations. Breakages can happen easily.

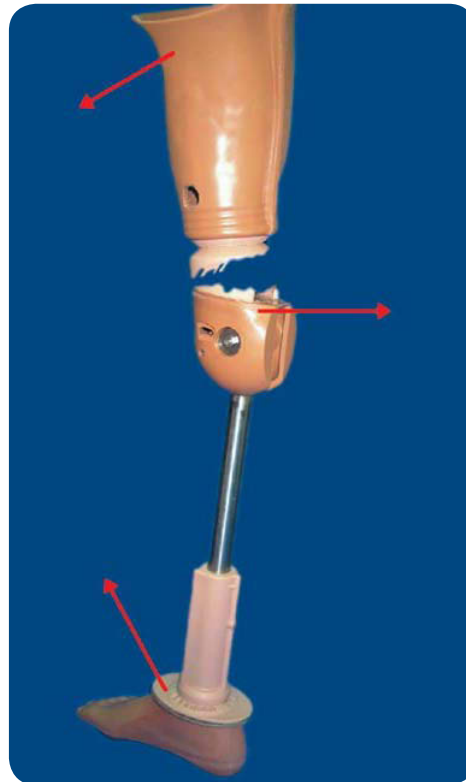
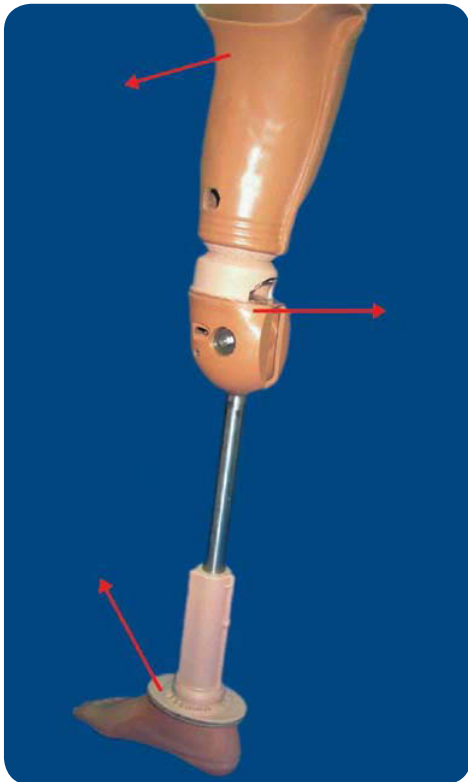

- ▼ Make sure the conical cup remains horizontal in both planes before welding it. Check also knee alignment and foot rotation.

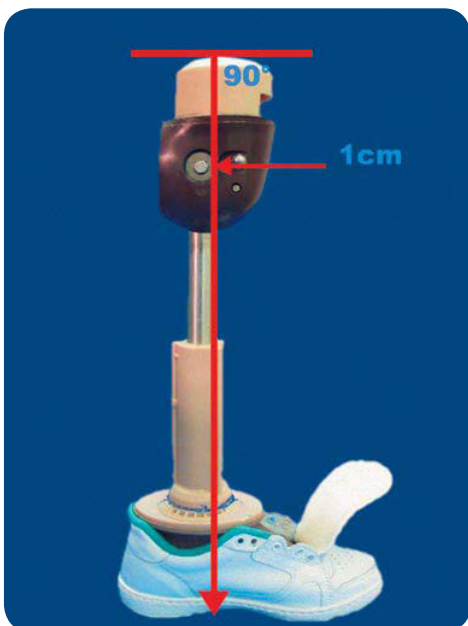

Welding the cylinders

- ▶ The temperature of the mirror should be between 185° and 200° C.



- ▶ Hold the cylinder on the mirror welder for no more than 5 minutes until a roll of melted PP is formed.

Weld according to the marks and apply slight pressure.

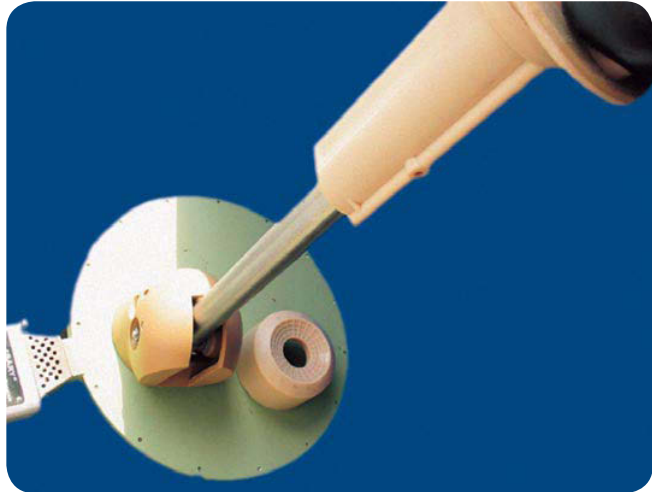

Length adjustment for a short stump

1. The socket is connected to the conical cup with a convex disc in between.
2. The second conical cup is connected to the knee-joint with another convex disc in between.
3. Once the height has been adjusted, the conical cups can be welded together.

Static or dynamic alignment can be done either above the knee-joint or below the socket.



Length adjustment for a long stump: Pay attention to minimum dimensions (see below)

- A** 22 mm for convex/concave plates
- B** 40 mm minimum distance between connection surface and axis of the knee

Dimensions to be determined:

- A** device for adjusting alignment
- B** distance between upper part of the knee-joint and knee axis

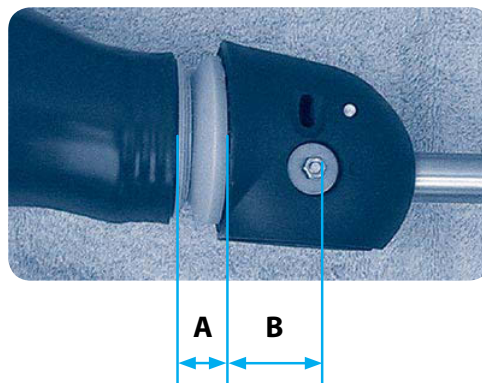

A = 22 mm (minimum)

B = 40 mm

Trans-Femoral componentry description

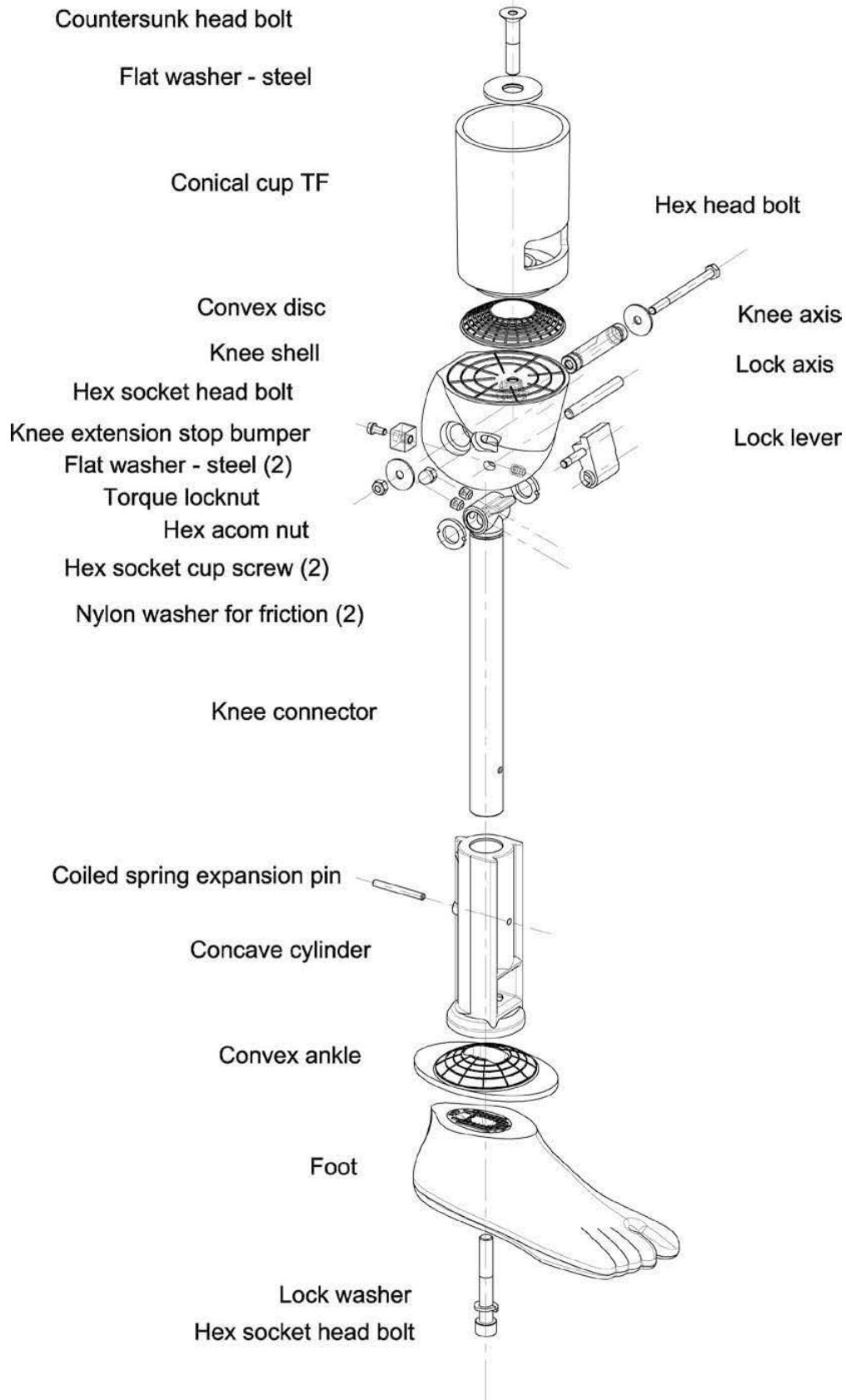

Trans-Femoral prosthesis setup

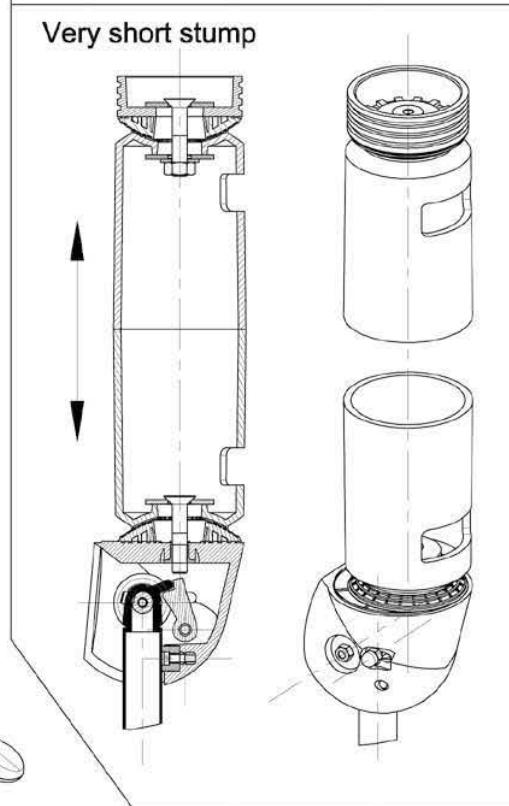
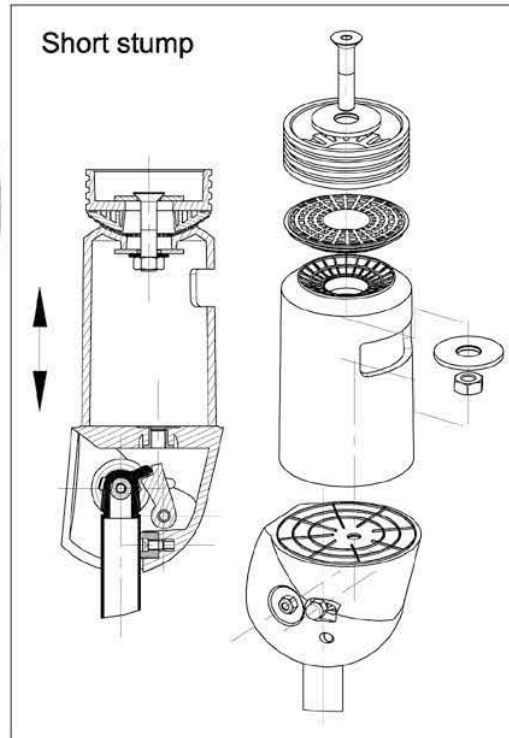
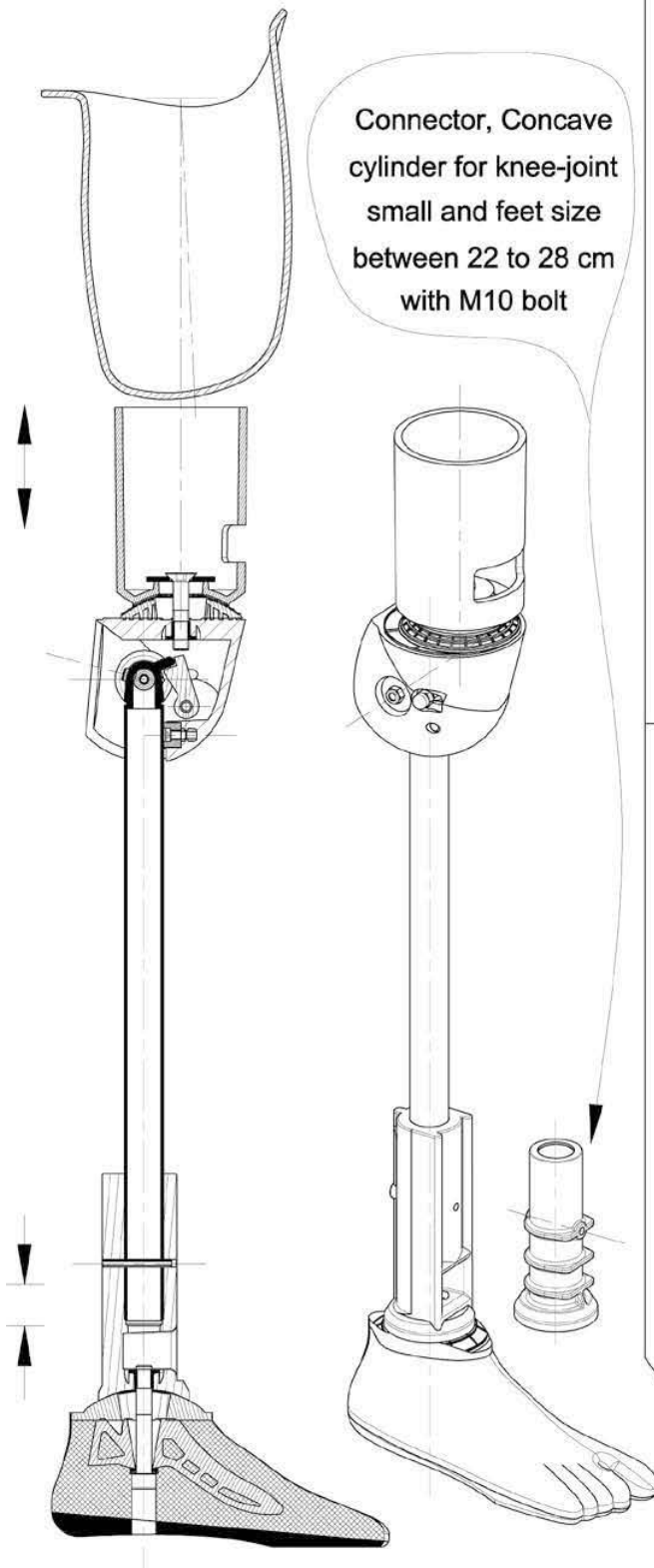

Final prosthesis alignment

- ▼ Modular PP technology allows sliding and tilting during alignment.

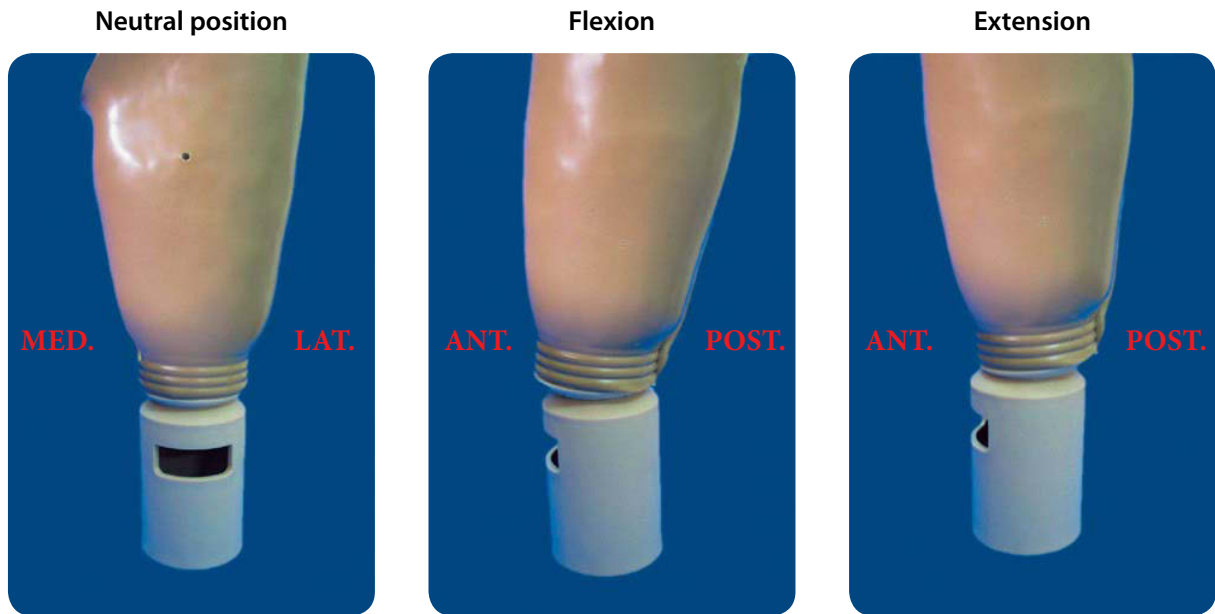

- ▼ Backward or anterior shifting is possible. Shifting can also occur medially or laterally.

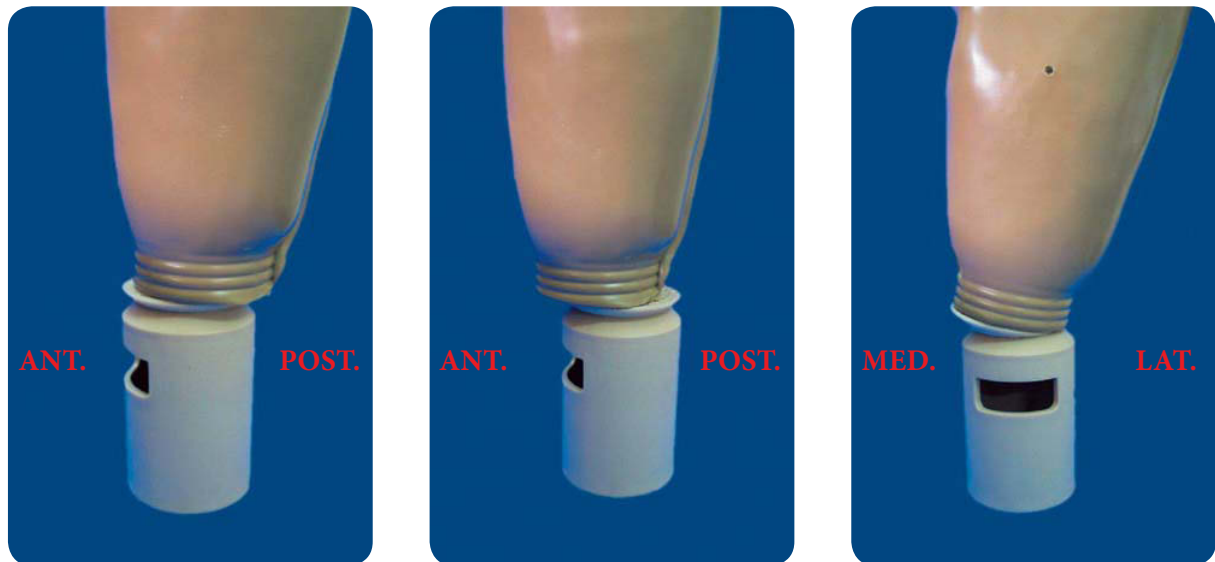

Belt manufacture

During the first fitting with the patient, the measurement for the belt is taken from the great trochanter, around the waist and above the opposite iliac crest as far as Scarpa's triangle.

The belt can be either a leather or a cotton strap, fixed with a 16 mm buckle.

Add 15 cm to the measurement taken on the patient to allow for adjustment during fitting.



- ▼ All components have to be welded together.

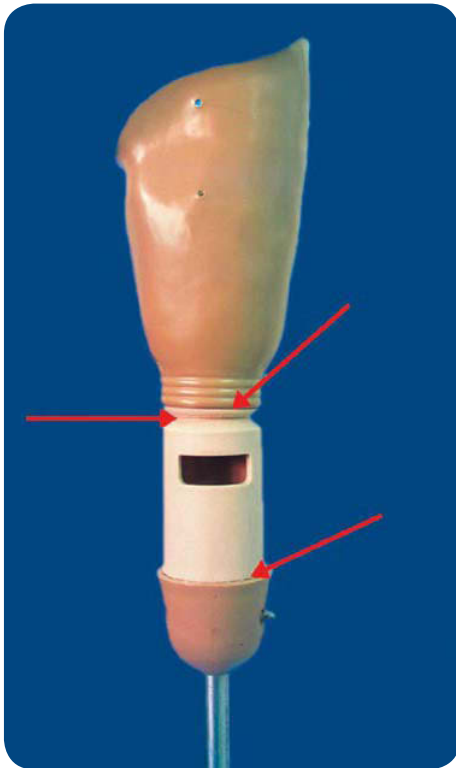

- ▼ Drill a 5 mm hole in the concave cylinder and the pipe.

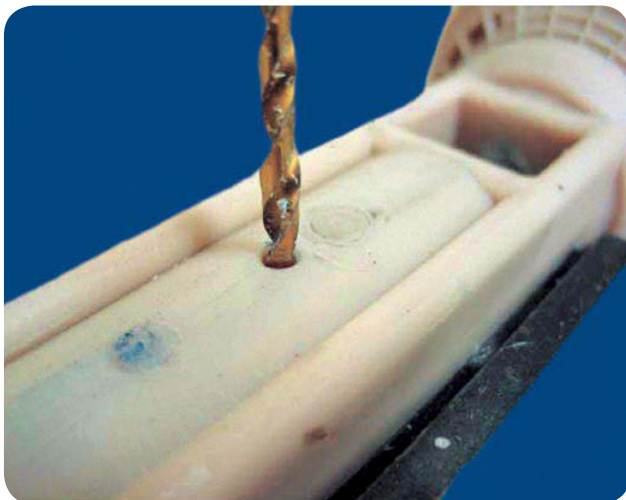

- ▼ Fix the expansion pin.



- ▶ Remove the excess PP for finishing at the ankle plate.

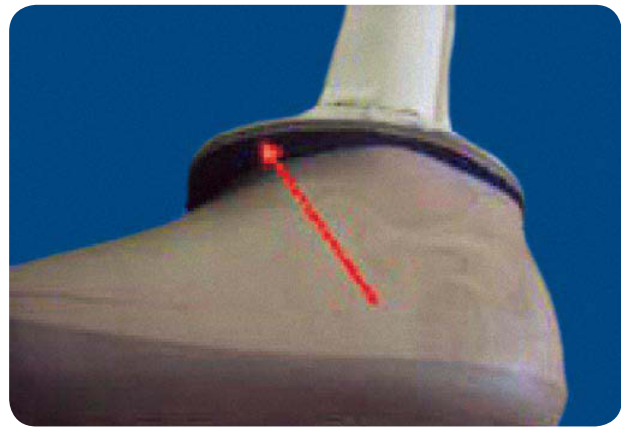

- ▶ Draw a line following the shape of the foot.

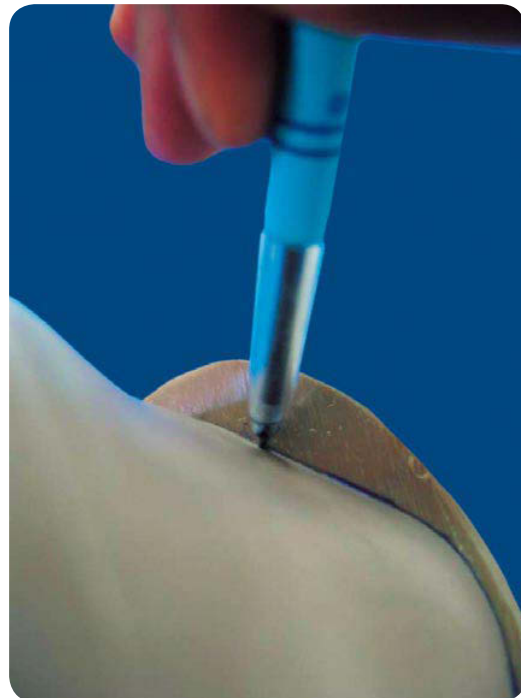

- ▶ Disassemble the foot.

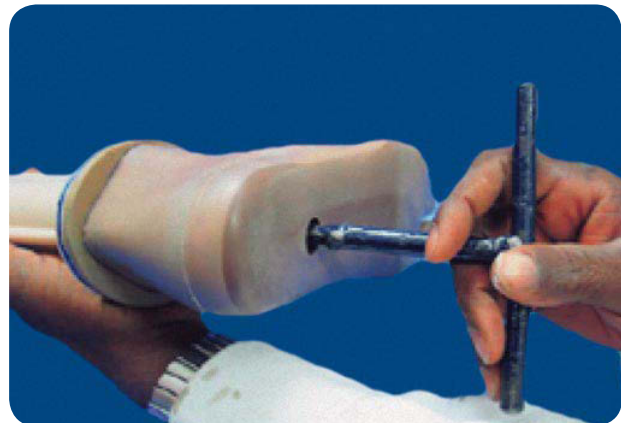

- ▼ Check your mark and grind it carefully. Check once more against the foot.

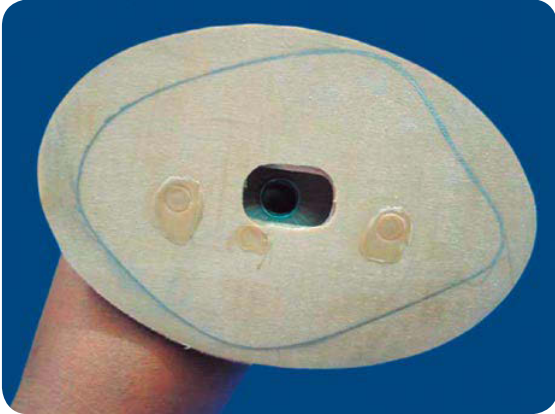

- ▶ Stick adhesive tape on the foot and make a mark with a permanent marker on the top of the convex ankle and on the tape.



- ▶ Remove the foot and draw a line all around the plate 4 mm from the edge.

Grind the edge carefully.

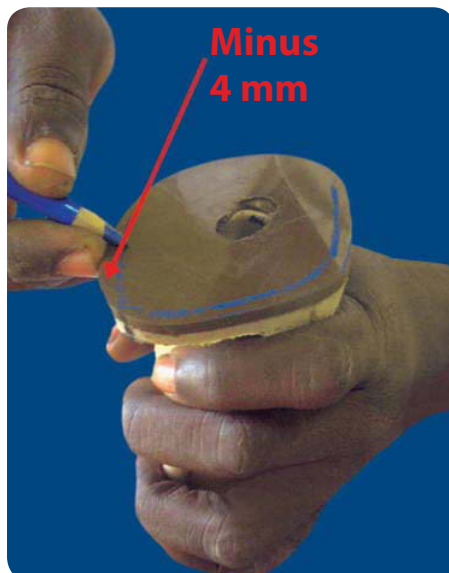

- ▶ Check again with the foot.

Once a good fit has been achieved, weld the two plates together: first make a groove with the welding iron and then weld with the hot-air welding gun.

Grind again to obtain a smooth finish.



- ▼ For heavy and active patients, a strip of 3 mm PP can be draped around the conical cup and alignment system for extra strength. Use an elastic bandage to tighten it well.

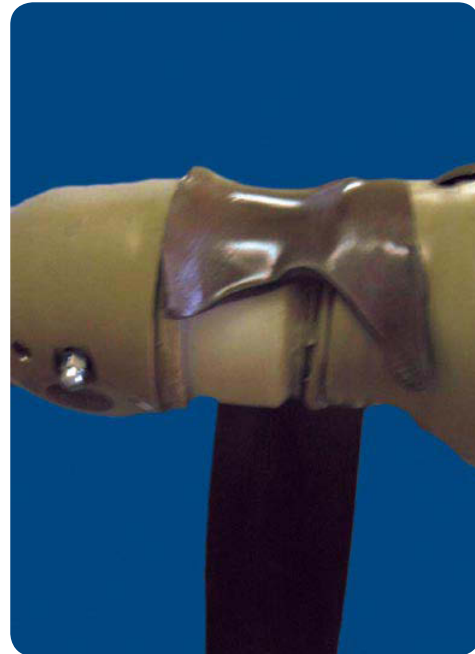

- ▶ When the PP has cooled down, grind the edges and weld.



- ▶ Protect the knee-joint with adhesive tape.

Grind the socket with sandpaper to roughen it.

Fill the socket with POP in order to fix the pipe.



- ▶ Shape the socket with plaster according to the measurement.

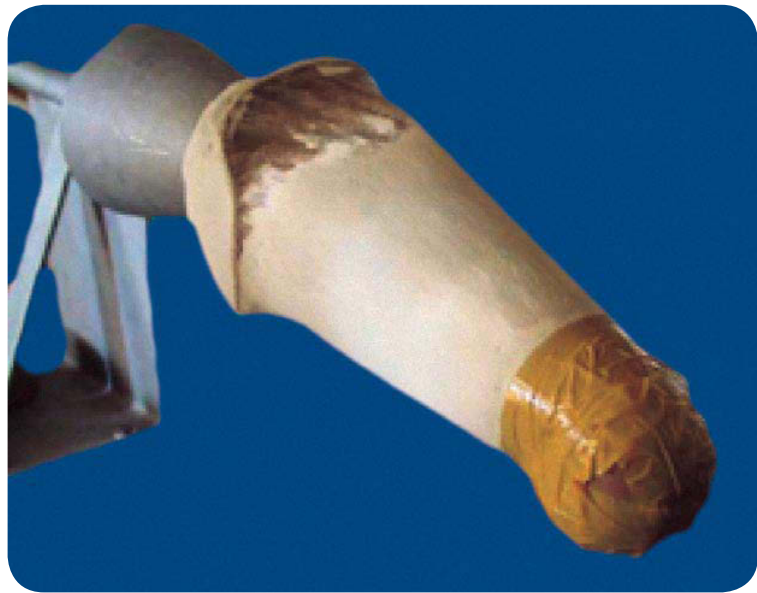

- ▶ Smooth the plaster and cover it with a stocking.

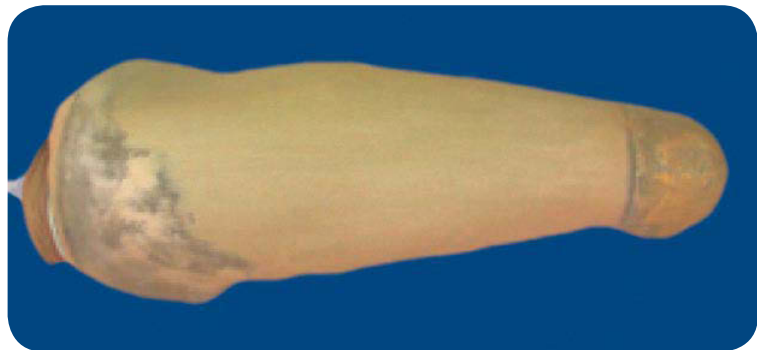

- ▶ Drape 4 mm PP around the socket in the same way as for the first socket.



- ▼ Once the PP has cooled down, remove the proximal part.

Use the oscillating saw to open the seam.

Remove the plaster and clean up the socket.

Trim the shell proximally and distally in line with the socket and the knee-joint.

Replace the shell on the socket.

Weld the seam.

Weld the proximal edge.

Weld the shell to the knee-joint.

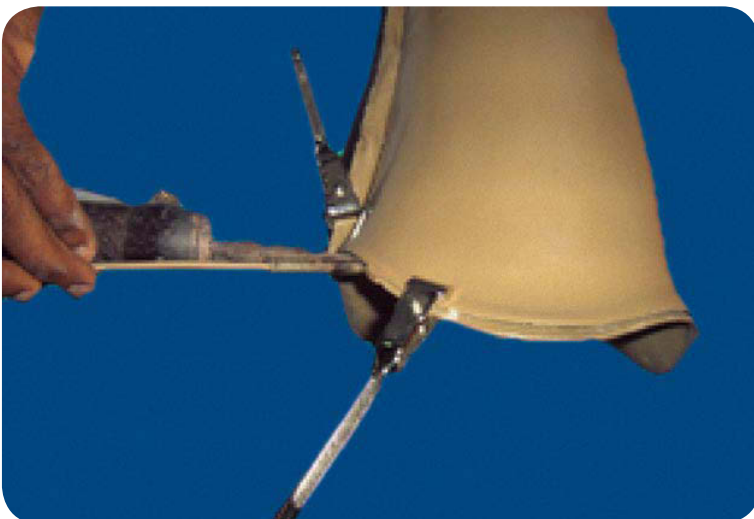
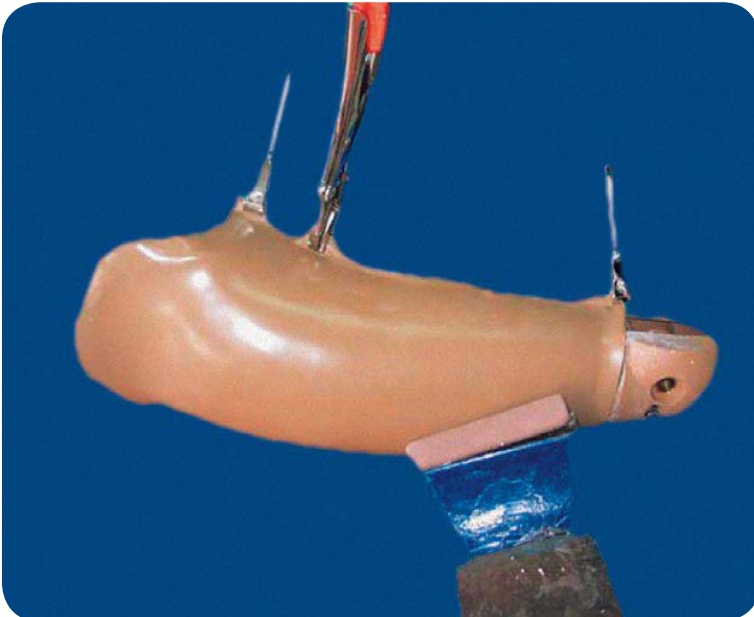

▶ When the welding is completed, remove the excess PP.

- Grind the seam between the shell and the knee-joint.
- The seam must be ground almost flush with the socket.
- Grind the proximal edge of the socket.

These three parts must then be polished.



▶ Protect the pipe and the knee-joint with tape.



▶ Shape the shank with POP and drape a sheet of 4 mm PP over it.

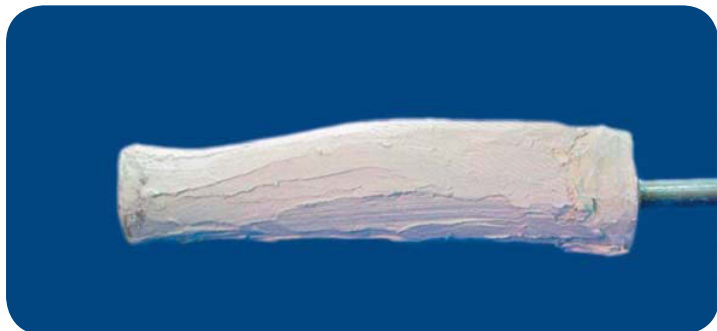

- ▶ Open the shell and remove the plaster.



- ▶ Insert the prosthesis into the cosmetic shell.

Determine and grind the proximal trim line for maximum flexion of the knee-joint.



- ▶ Weld the seam and the ankle connection.



- ▶ Grind and smooth the welding.



- ▼ Insert an EVA washer cut to the same shape as the shank about 10 cm below the knee-joint to keep the cosmetic shank in place. This will also prevent creaking.

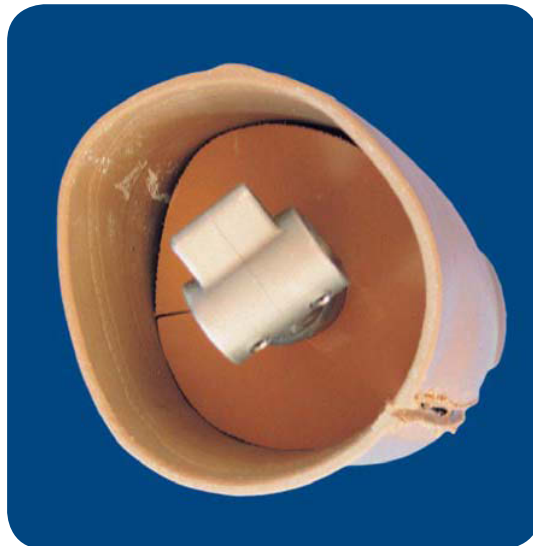
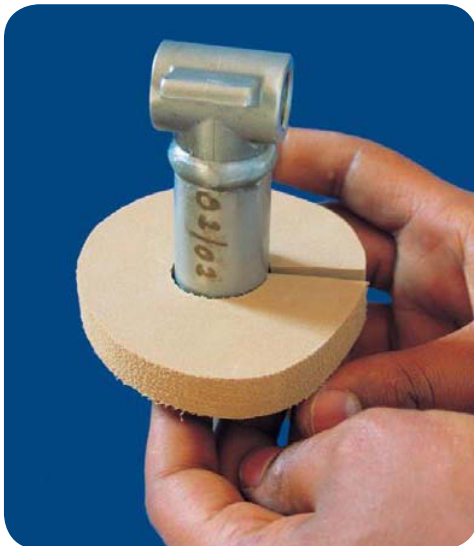

- ▶ Fix the knee-joint back onto the shank.
Fix the belt.



- ▼ Roughen the EVA before applying it to the PP socket. Glue layers of EVA on the socket and shape it. A final layer of 3 mm EVA will cover the entire prosthesis, increasing the circumference by 1 cm.

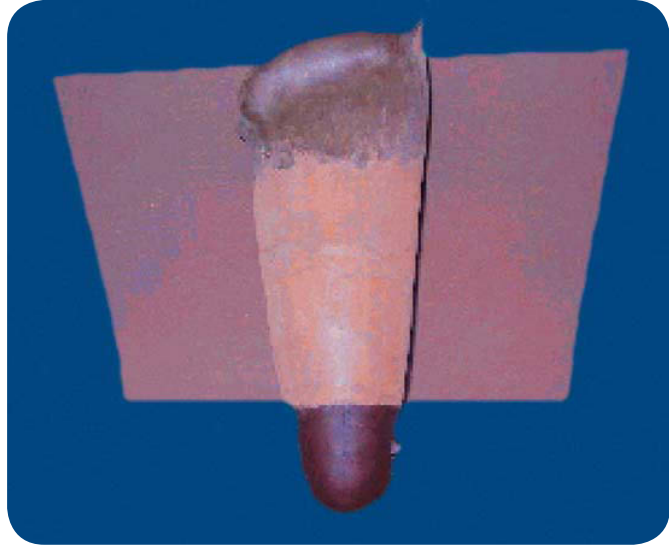

- ▶ Cut a sheet of 12 mm EVA corresponding to the circumference of the wooden or plaster model shank. Skive both sides of the EVA and glue.

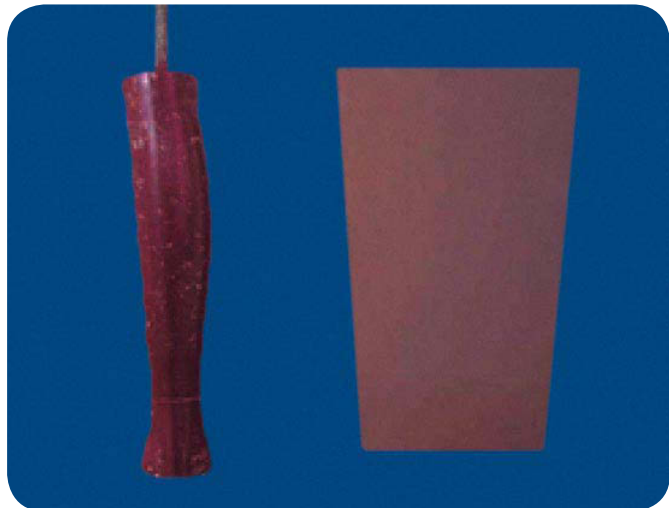

- ▶ Place the sheet of EVA in the oven at about 120° until it becomes soft, then bend it to obtain a conical shape. Add talcum powder inside the cone and put it back in the oven.



- ▶ Pull the EVA cone over the model shank and tighten it with an elastic bandage, or use a vacuum system.



- ▶ Cut the posterior proximal edge to allow flexion of the knee-joint.



- ▶ **Tip:** for finishing purposes, wind a tape around the proximal aspect of the foot to prevent damage to the foot cosmetic during grinding of the EVA.



- ▶ Shape the shank according to the measurements taken on the sound leg. Then glue it distally on top of the foot.

Insert an EVA washer cut to the shape of the shank about 10 cm below the knee-joint to keep the cosmetic shank in place.

Fix the shank to the socket. Fix the belt.

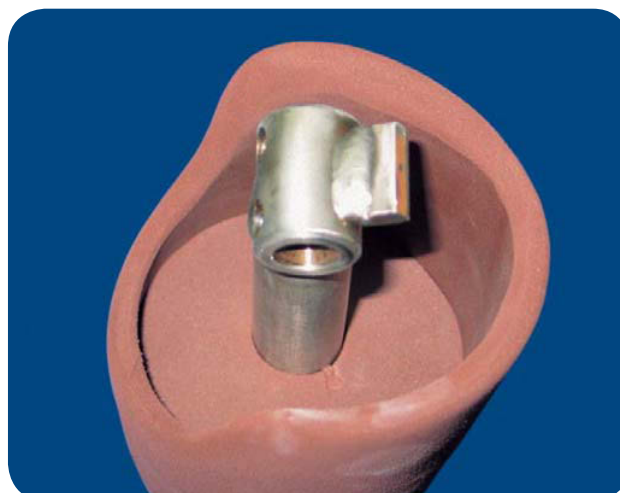

Reference list of materials

CR Equipements

1.1 COMPONENTS FOR TRANS-FEMORAL PROSTHESIS, ADULT

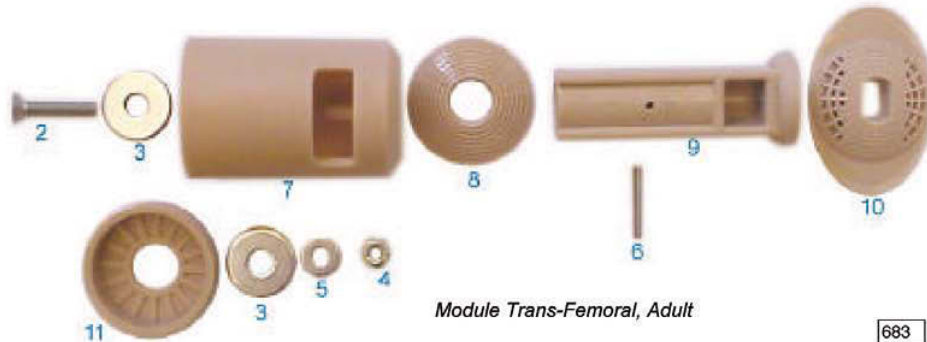

683

CRE Code	Description	Specification	Unit of measure	Weight per unit of measure	Quant. per Box	Box size	
CRE 683	OCPOMODUTFA	Module Trans-Femoral alignment, Adult	Beige colour only	each	0.52 kg	25 sets	L40 x I30 : H44cm
<i>Setup of module</i>							
	2	Countersunk head bolt, full thread	M10 x 50mm	1pc	<i>Articles only available as a complete kit. (cannot be ordered seperately)</i>		
	3	Flat washer - steel	D54 x d15 x H3mm	2 pcs			
	4	Nut - steel	M10	1 pc			
	5	Flat washer - steel	D25 x d10.5 x 2mm	1 pc			
	6	Coiled spring expansion pin	D5 x L45mm	1 pc			
	7	Conical cup Trans-Femoral adult	D85 x L128mm	1 pc			
	8	Convex disc	D80 x L14mm	1 pc			
	9	Concave cylinder with T-nut M10	diam. 25mm	1 pc			
	10	Convex ankle		1 pc			
	11	Cup Trans-Femoral		1 pc			

1.2 KNEE-JOINT MEDIUM



Knee-joint medium

CRE Code	Description	Specification	Unit of measure	Weight per unit of measure	Quant. per Box	Box size	
CRE 669	OCPOKNEEKIML	Knee-joint medium Left, Beige colour	Tube diam. 25mm	each	0.84 kg	25 pcs	L59 x I39.5 x H40cm
CRE 670	OCPOKNEEKIMR	Knee-joint medium Right, Beige colour	Tube diam. 25mm	each			
CRE 671	OCPOKNEELIML	Knee-joint medium Left, Olive colour	Tube diam. 25mm	each			
CRE 672	OCPOKNEELIMR	Knee-joint medium Right, Olive colour	Tube diam. 25mm	each			
CRE 673	OCPOKNEEERML	Knee-joint medium Left, Terra colour	Tube diam. 25mm	each			

CR Equipements

1.2.1 KNEE-JOINT MEDIUM WITH BLOCKING SPRING

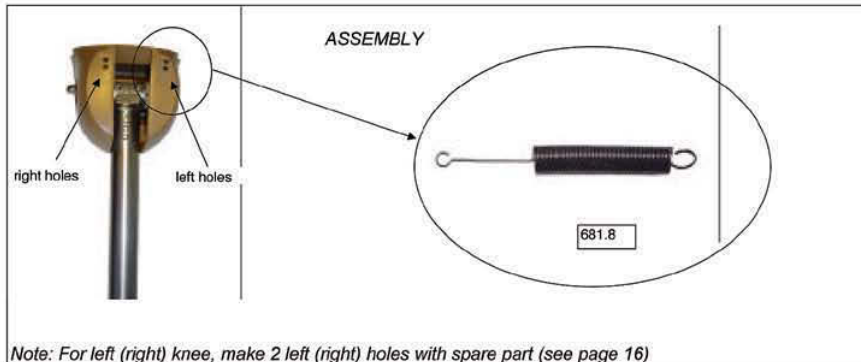

Note: For left (right) knee, make 2 left (right) holes with spare part (see page 16)

CRE Code	Description	Specification	Unit of measure	Weight per unit of measure	Quant. per Box	Box size
CRE 681.8	Knee-joint medium with blocking spring	Kit	25 pcs			plastic bag

See reference of spare parts for knee-joint with blocking spring, page: 16

1.3 COMPONENTS FOR TRANS-FEMORAL PROSTHESIS, CHILD

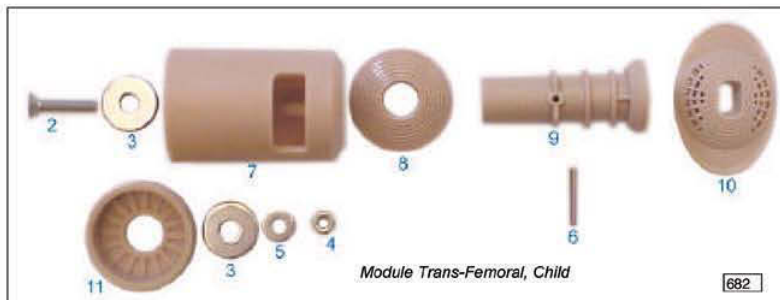

CRE 682	OCPOMODUTFC	Module Trans-Femoral alignment, Child	Beige colour only	each	0.395 kg	25 sets	L40 x I30 x H44cm
---------	-------------	---------------------------------------	-------------------	------	----------	---------	-------------------

Setup of module

2	Countersunk head bolt, full thread	M10 x 50mm	1 pc
3	Flat washer - steel	D44 x d15 x H3mm	2 pcs
4	Nut - steel	M10	1 pc
5	Flat washer - steel	D25 x d10.5 x 2mm	1 pc
6	Coiled spring expansion pin	D5 x L40mm	1 pc
7	Conical cup Trans-Femoral child	D70 x L105mm	1 pc
8	Convex disc	D80 x L14mm	1 pc
9	Concave cylinder, with T-nut M8	diam. 22mm	1 pc
10	Convex ankle		1 pc
11	Cup Trans-Femoral		1 pc

Articles only available as a complete kit.
(cannot be ordered separately)

1.4 CONNECTOR

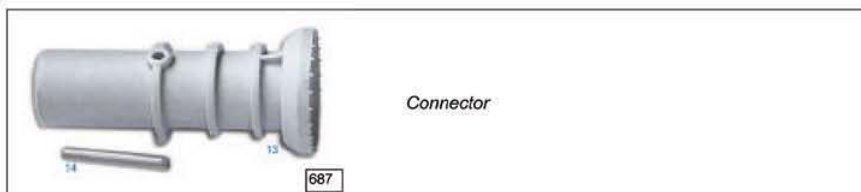

CRE 687	OCPOMODUTFCA	Connector, Concave cylinder for knee-joint small and foot size between 22 to 28 with M10 bolt	Gray colour only	each	0.075 kg	25 pcs	L30 x I20 x H20cm
---------	--------------	---	------------------	------	----------	--------	-------------------

Setup of module

13	Coiled spring expansion pin	D5 x L40mm	1 pc
14	Concave cylinder with T-nut M10		1 pc

Articles only available as a complete kit.
(cannot be ordered separately)

CR Equipements

1.5 KNEE-JOINT SMALL



CRE Code	Description	Specification	Unit of measure	Weight per unit of measure	Quant. per Box	Box size
CRE 676	OCPOKNEEKISL Knee-joint small Left, Beige colour	Tube diam. 22mm	each	0.58 kg	25 pcs	L40 x I30 x H44cm
CRE 677	OCPOKNEEKISR Knee-joint small Right, Beige colour	Tube diam. 22mm	each			
CRE 678	OCPOKNEELISL Knee-joint small Left, Olive colour	Tube diam. 22mm	each			
CRE 679	OCPOKNEELISR Knee-joint small Right, Olive colour	Tube diam. 22mm	each			
CRE 680	OCPOKNEEERSL Knee-joint small Left, Terra colour	Tube diam. 22mm	each			
CRE 681	OCPOKNEEERSR Knee-joint small Right, Terra colour	Tube diam. 22mm	each			

See reference of spare parts for knee-joint, page: 15

Foot

See reference of foot size between 17cm to 21cm

1.5.1 KNEE-JOINT SMALL WITH BLOCKING SPRING

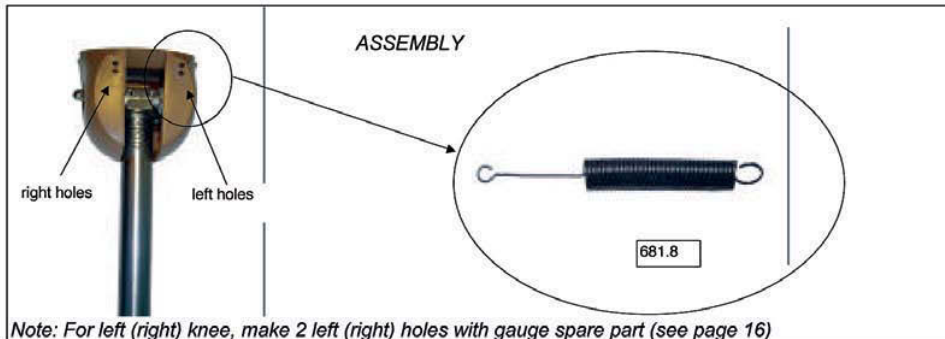

CRE 681.8	Knee-joint small with blocking spring	Kit	25 pcs	plastic bag
-----------	---------------------------------------	-----	--------	-------------

See reference of spare parts for knee-joint with blocking spring, page: 16

CR Equipements

1.9 COMPONENTS FOOT FOR PROSTHESIS

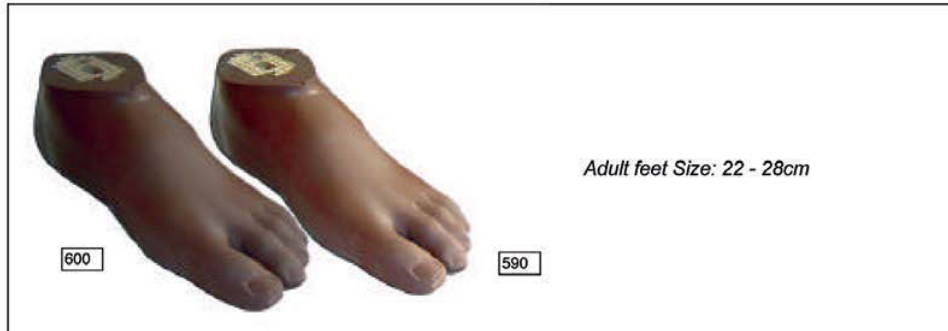

CRE Code	Description	Specification	Unit of measure
OCPOFOOT....	Foot ...cm, Left or Right, Olive or Terra colour	22 - 28 cm	each
CRE 605.27.R	OCPOFOOTER27R Foot Right, Terra colour	27 cm	each

To order the articles, please use the complete CRE codes on the pricelist, carefully choosing the colour and the size.
 Example: To order 1 foot of 27cm, Terra colour, Right. Please choose in the price list the following:

The colour of the feet on this picture do not necessarily match the real colours. Sample of foam can be supplied on request.

All the adult feet, include one M10 bolt and one lock washer M10
 Heel = 10mm

See reference of spare parts for foot, page: 16



CRE Code	Description	Specification	Unit of measure
OCPOFOOT....	Foot ...cm, Left or Right, Olive or Terra colour	14 - 21 cm	each
CRE 630.19.L	OCPOFOOTER19L Foot Left, Terra colour	19 cm	each

To order the articles, please use the complete CRE codes on the pricelist, carefully choosing the colour and the size.
 Example: To order 1 foot of 19cm, Terra colour, Left. Please choose in the price list the following:

The colour of the feet on this picture do not necessarily match the real colours. Sample of foam can be supplied on request.

CR Equipements

1.13 SPARE PARTS AND SPECIAL TOOLS FOR COMPONENTS

SPARE PARTS FOR KNEE-JOINT

CRE Code	Description	Specification	Unit of measure	Weight per unit of measure	Quant. per packet	Box size
CRE 692	OTOOLUBRM19EP	Grease, Motorex 190 EP, for knee joint	box = 1 kg	each	1 kg	each
CRE 693	OTOOGLUEDOCB243	Glue, Loctite blue no. 243, for knee joint	btl. = 50 ml	each	0.05 kg	each
CRE 694	KORTKNEESP	Kit, spares parts for knee joint, adult / child		each	4.15 kg	each
	<i>Setup kit</i>					
694.1	Ball, stainless steel	D4mm	100 pcs	<i>Articles only available as a complete kit (cannot be sold seperately)</i>		
694.2	Hex acon nut, stainless steel	M6	100 pcs			
694.3	Washer in polyamid	D12 x d 6 x H1mm	100 pcs			
694.4	Hex head bolt, stainless steel for knee-joint adult	M6 x L80mm	100 pcs			
694.5	Hex head bolt, stainless steel for knee-joint small	M6 x L 70mm	30 pcs			
694.6	Torque locknut, stainless steel	M6	100 pcs			
694.7	Washer, stainless steel	D25 x d6.4 x H1.5mm	200 pcs			
694.8	Washer in nylon for friction	D24 x d14 x H3mm	200 pcs			



681.1



681.2

CRE 681.1	OCPOKNEESTOPM	Extension stop bumper with screw for knee-joint medium	M5	10 pcs
CRE 681.2	OCPOKNEESTOPS	Extension stop bumper with screw for knee-joint small	M4	10 pcs

CR Equipements

1.14 RAW MATERIALS

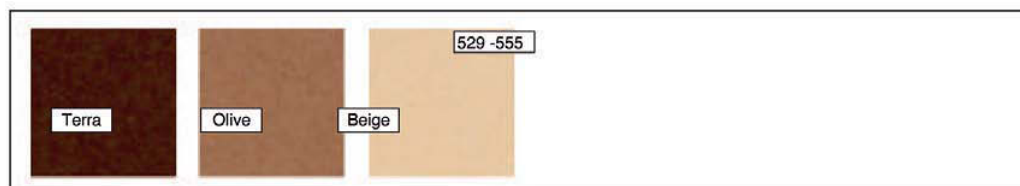

CRE Code	Description	Specification	Unit of measure	Weight per unit of measure	
CRE 529	OPLAEVAFERA03	EVA FOAM, 3mm x 0.95m x 0.95m, 0.90m ² , terra brown	Terra	each	0.46 kg
CRE 530	OPLAEVAFERA06	EVA FOAM, 6mm x 0.95m x 0.95m, 0.90m ² , terra brown	Terra	each	0.92 kg
CRE 531	OPLAEVAFERA12	EVA FOAM, 12mm x 1.10m x 1.10m, 1.21m ² , terra brown	Terra	each	1.2 kg
CRE 533	OPLAEVAFKIN03	EVA FOAM, 3mm x 0.95m x 0.95m, 0.90m ² , beige	Beige	each	0.46 kg
CRE 534	OPLAEVAFKIN06	EVA FOAM, 6mm x 0.95m x 0.95m, 0.90m ² , beige	Beige	each	0.92 kg
CRE 536	OPLAEVAFKIN12	EVA FOAM, 12mm x 1.10m x 1.10m, 1.21m ² , beige	Beige	each	1.2 kg
CRE 537	OPLAEVAFLIV03	EVA FOAM, 3mm x 0.95m x 0.95m, 0.90m ² , olive	Olive	each	0.46 kg
CRE 538	OPLAEVAFLIV06	EVA FOAM, 6mm x 0.95m x 0.95m, 0.90m ² , olive	Olive	each	0.92 kg
CRE 539	OPLAEVAFLIV12	EVA FOAM, 12mm x 1.10m x 1.10m, 1.21m ² , olive	Olive	each	1.2 kg
CRE 544	OPLAPOLYSKIN03	PPH (POLYPROPYLEN HOMOPOLYMER), 3mm x 1m x 2m, beige colour	Beige	each	5.5 kg
CRE 545	OPLAPOLYSKIN04	PPH (POLYPROPYLEN HOMOPOLYMER), 4mm x 1m x 2m, beige colour	Beige	each	7.5 kg
CRE 546	OPLAPOLYSKIN05	PPH (POLYPROPYLEN HOMOPOLYMER), 5mm x 1m x 2m, beige colour	Beige	each	9.2 kg
CRE 547	OPLAPOLYRKI04	POLYPROPYLENE WELDING ROD, diam. 4mm, beige colour, roll	Beige	each	5 kg
CRE 548	OPLAPOLYCHOC03	PPH (POLYPROPYLEN HOMOPOLYMER), 3mm x 1m x 2m, terra colour	Terra	each	5.6 kg
CRE 549	OPLAPOLYCHOC04	PPH (POLYPROPYLEN HOMOPOLYMER), 4mm x 1m x 2m, terra colour	Terra	each	7.5 kg
CRE 550	OPLAPOLYCHOC05	PPH (POLYPROPYLEN HOMOPOLYMER), 5mm x 1m x 2m, terra colour	Terra	each	9.2 kg
CRE 551	OPLAPOLYRCH04	POLYPROPYLENE WELDING ROD, diam. 4mm, terra colour, roll	Terra	each	5 kg
CRE 552	OPLAPOLYLIV03	PPH (POLYPROPYLEN HOMOPOLYMER), 3mm x 1m x 2m, olive colour	Olive	each	5.5 kg
CRE 553	OPLAPOLYLIV04	PPH (POLYPROPYLEN HOMOPOLYMER), 4mm x 1m x 2m, olive colour	Olive	each	7.5 kg
CRE 554	OPLAPOLYLIV05	PPH (POLYPROPYLEN HOMOPOLYMER), 5mm x 1m x 2m, olive colour	Olive	each	9.2 kg
CRE 555	OPLAPOLYRLI04	POLYPROPYLENE WELDING ROD, diam. 4mm, olive colour, roll	Olive	each	5 kg

PP, EVA and other consumables

Designation	Used for
Materials	
POP bandage 15 cm	Cast-taking
POP powder	Positive mould
Contact glue	Soft socket
Soap (demoulding agent)	Positive mould
Talcum powder	Thermoforming
Vaseline	Cast-taking
Nails	Positive mould
Colorant for plaster	Positive mould
Cotton/nylon stockinet dia. 8 or 10 cm	Cast-taking
Cotton stockinet or sock	Stump sock
PP welding rod dia. 4 mm	Welding components
Polypropylene 5 mm	Hard socket
Polypropylene cosmetic	
Polypropylene 4 mm	Cosmetic shell
PP welding rod dia. 4 mm	Welding components
POP powder	Cosmetic shape
Adhesive tape	
EVA cosmetic	
EVA 3 mm; 6 mm; 12 mm	
Contact glue	

MISSION

The International Committee of the Red Cross (ICRC) is an impartial, neutral and independent organization whose exclusively humanitarian mission is to protect the lives and dignity of victims of war and internal violence and to provide them with assistance. It directs and coordinates the international relief activities conducted by the Movement in situations of conflict. It also endeavours to prevent suffering by promoting and strengthening humanitarian law and universal humanitarian principles. Established in 1863, the ICRC is at the origin of the International Red Cross and Red Crescent Movement.

Acknowledgements:

Jean François Gallay
Leo Gasser
Pierre Gauthier
Frank Joumier
Jacques Lepetit
Bernard Matagne
Joel Nininger
Guy Nury
Peter Poetsma
Hmayak Tarakhchyan

and all prosthetists-orthotists who have worked in ICRC-assisted physical rehabilitation centres.



ICRC

MIT OpenCourseWare
<http://ocw.mit.edu>

EC.722 Special Topics at Edgerton Center:Developing World Prosthetics
Spring 2010

For information about citing these materials or our Terms of Use, visit: <http://ocw.mit.edu/terms>.