

CHOLINERGIC TRANSMISSION: PHYSIOLOGY AND GENERAL
PHARMACOLOGY

Objectives: The purpose of this lecture is to describe the mechanisms and pharmacology of nicotinic and muscarinic cholinergic transmission. Cholinergic transmission is defined by the physiological processes that utilize acetylcholine to communicate between cells. We will address the following questions:

- 1. Where does cholinergic transmission occur?**
- 2. What biochemical events underly cholinergic transmission and how do drugs alter these events?**
- 3. What are the physiological consequences of cholinergic transmission, and of its absence?**

I. Distributions and varieties of cholinergic transmission:

Neurotransmission using acetylcholine (ACh) occurs in the peripheral (PNS) and central nervous systems (CNS). Direct control of skeletal muscle tension is mediated by ACh released at the neuromuscular junction (nmj), and modulation of timing (chronotropy) and tension (inotropy) in cardiac and smooth muscle is effected through ACh released by postganglionic parasympathetic neurons. The *excitatory* aspect of neurotransmission at autonomic ganglia requires ACh, as does a variety of still cryptic mechanisms in the CNS. **Cholinergic receptors are broadly classified as nicotinic (nAChR) or muscarinic (mAChR), although these are further subdivided by their selective pharmacologies (more on this below).**

Common to all these neurotransmissions are basic processes for the synthesis, storage, release, and breakdown of acetylcholine by synaptic endings of neurons, and for the binding of transmitters by postsynaptic receptors and their subsequent activation. Specific examples of these processes and of agents that selectively interfere with them during neuromuscular transmission are shown in the following Figures:

Fig1a

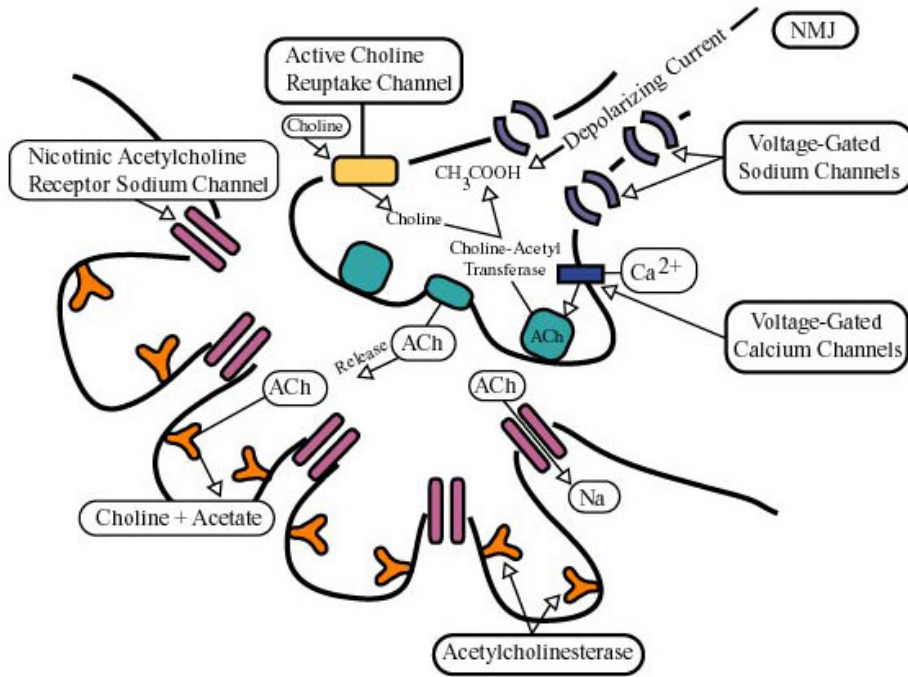
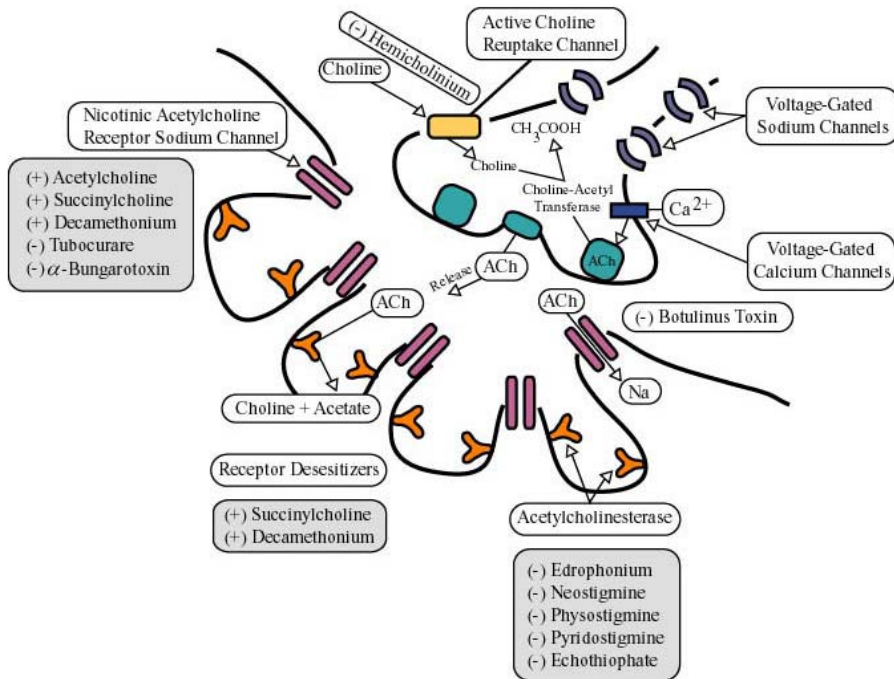

Fig1b



Other examples are listed in Table 1 below, which also includes **adrenergic transmission, the other aspect of autonomic synaptic activity whose actions, subserving sympathetic n.s. activation, often antagonize the effects of parasympathetic (cholinergic) innervation of end organs** (e.g. heart, gut, etc., see also figure 2A). Details of adrenergic pharmacology will be presented later.

Table 1

Mechanism	System	Agents	Effect
Interference with synthesis of transmitter	Cholinergic	Hemicholinium	Block choline uptake and deplete ACh
	Adrenergic	α -Methyltyrosine	Deplete NE
Metabolism by same path as transmitter	Adrenergic	α -Methyldopa	Displacement of NE by, α -methylNE, a false transmitter
Blockade of transport at nerve terminal membrane	Adrenergic	Cocaine, imipramine	Accumulation of NE at receptors
Blockade of transport into storage granules	Adrenergic	Reserpine	NE depletion from adrenergic terminal
Displacement of transmitter from terminal	Cholinergic	Latrotoxin (black widow venom)	Cholinomimetic followed by block
	Adrenergic	Amphetamine, tyramine	Sympathomimetic
Prevent release of transmitter	Cholinergic	Botulinus toxin	Anticholinergic
	Adrenergic	Bretylium, guanethidine	Antiadrenergic
Agonist at postsynaptic receptors	Cholinergic (Nicotinic)	Nicotine, succinylcholine	Cholinomimetic
	Cholinergic (Muscarinic)	Muscarine, methacholine	Cholinomimetic
	Adrenergic (α 1)	Phenylephrine	Sympathomimetic

Agonist at postsynaptic receptors	Adrenergic (α_2)	Clonidine	Sympathomimetic (periphery), sympatholytic (CNS)
	Adrenergic (β_1)	Dobutamine	Cardiac M. stimulation
	Adrenergic (β_2)	Albuterol	Sm. M. relaxation
Antagonist at postsynaptic receptors	Cholinergic (nicotinic)	d-Tubocurarine	Anticholinergic
	Cholinergic (muscarinic)	Atropine	Anticholinergic
	Adrenergic (α_1)	Prazosin	Vasodilation
	Adrenergic (β_1)	Metoprolol	Cardiac blockade
Inhibition of transmitter breakdown	Cholinergic	Physostigmine, DFP	Cholinomimetic
	Adrenergic	MAO inhibitors (pargyline), COMT inhibitors (entacapone)	Potentiate indirect acting sympathomimetics

At this point you will probably benefit by an anatomical review of the autonomic nervous system (see Katzung and Fig. 2 this handout). Accompanying the general anatomy of the sympathetic and parasympathetic n.s. are **the specific effects of acetylcholine** (and norepinephrine) on particular end organs.

Fig 2a

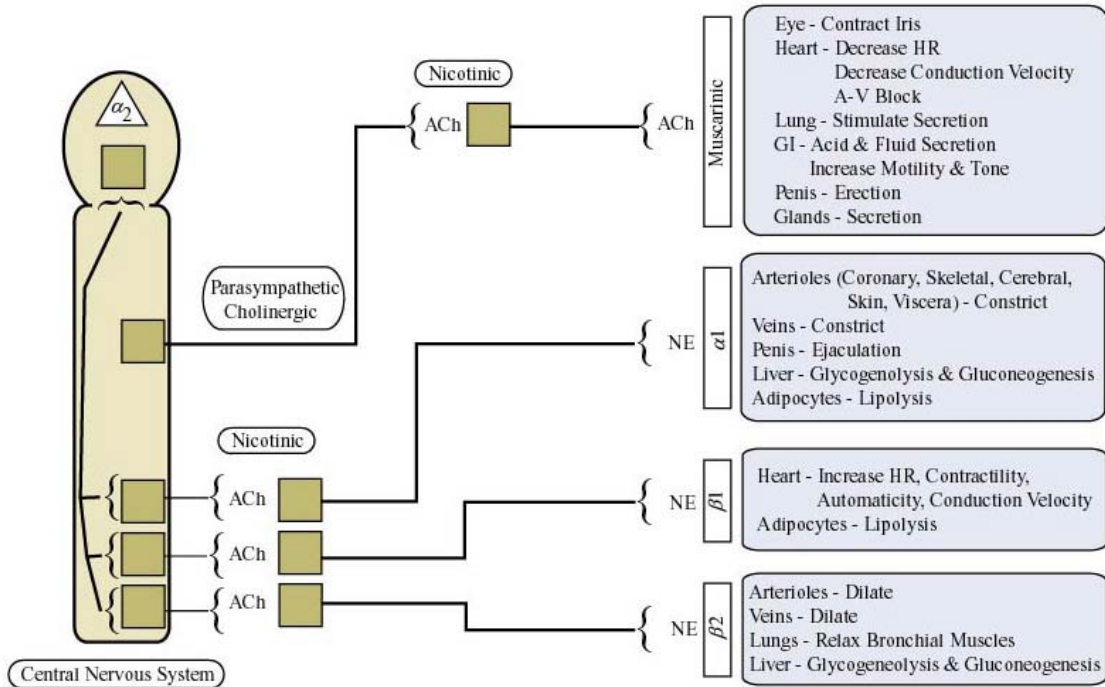
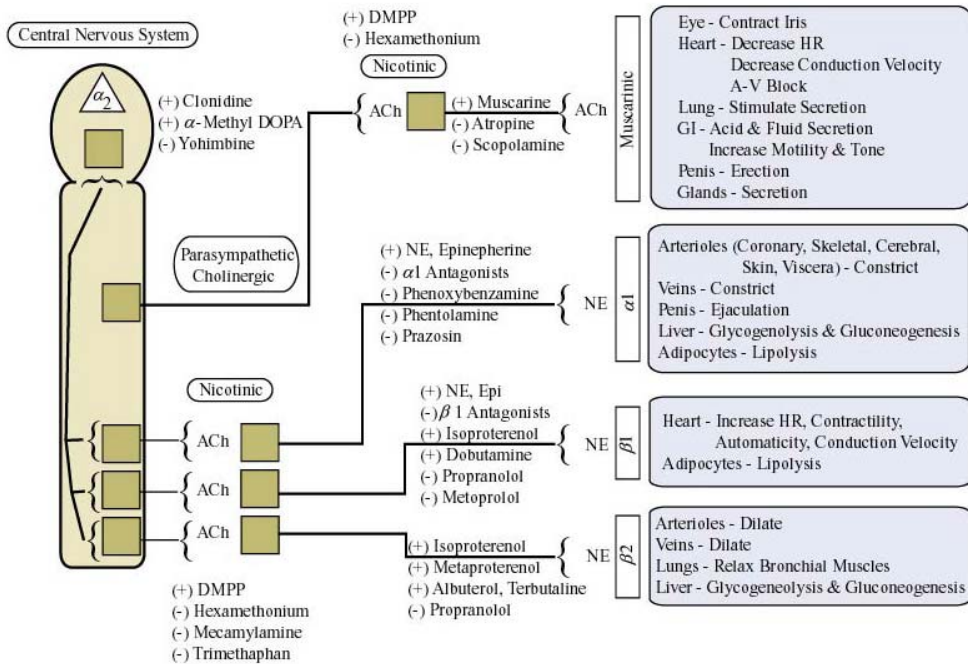
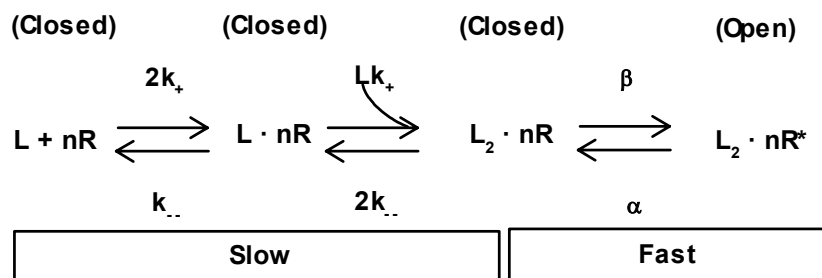

Fig 2b



A. Nicotinic Cholinergic Transmission. Familiar to you from earlier lectures on neuromuscular transmission, **nicotinic cholinergic transmission results directly from the binding of ACh (2 molecules) to the nAChR, yielding an example of a directly ligand-gated conductance**. The nAChR (nR in scheme below), when bound by 2 agonist ligands (L), undergoes a conformational change to form a monovalent cation-selective pore through the postsynaptic membrane.



Single open channels of the activated nAChR are about equally permeable to Na^+ and K^+ ions; their activation in a resting cell thus produces a net inward ionic current ($E_{\text{rev}} \sim -10\text{mV}$) that depolarizes the postsynaptic membrane. Depolarization has a variety of consequences: e.g. depolarizations are additive, summing temporally and spatially ("integration") to bring a postsynaptic excitable cell's membrane to impulse threshold, thereby activating voltage-gated Ca^{2+} channels to increase intracellular Ca^{2+} or directly modulating other voltage-gated channels, as well as producing other, long term changes.

The fast nicotinic depolarization is very brief (<10 ms), as the ACh is rapidly hydrolyzed by acetylcholine-esterase (AChE) in the synaptic cleft and the receptor-

bound ACh dissociates quickly from the "closed" receptor. The time course of the various stages of neuromuscular transmission is outlined in figure 3:

Agents that prevent the binding of ACh to the receptor yet have no activating capacity of their own (e.g. d-tubocurarine) are **non-depolarizing antagonists** of nicotinic transmission. Those that **mimic the effects (e.g. carbachol) are agonists**, and those that **activate it, but less efficaciously than ACh (e.g. methacholine), are mixed agonists-antagonists** (sometimes called **partial agonists**; see Figure 4a). Cholinergic agonists that are resistant or insensitive to AChE (e.g. succinylcholine) can have an apparent in vivo potency (e.g. when administered intravenously to an intact animal) far in excess of ACh's. Paradoxically, these agents are used as "**depolarizing blockers** of nicotinic transmission, because their persistent activation of nAChR at the nmj results in a continuous depolarization of the muscle end-plate and, by electrotonic spread, of the adjacent excitable muscle membrane, rendering it refractory to action potential generation. (Do you recall the role of Na channel inactivation and K⁺ channel activation on impulse threshold?)

Figure 4a

Flux of cations into Vesicles Containing Nicotinic Cholinergic Channels Activated By:

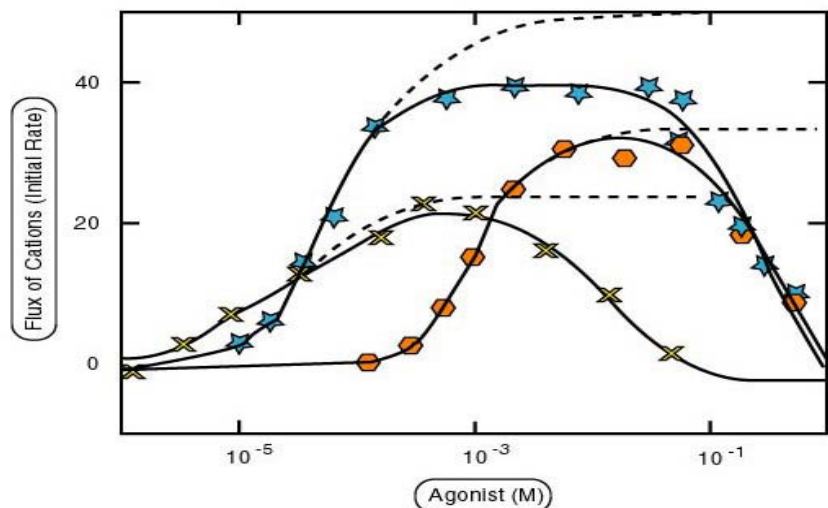
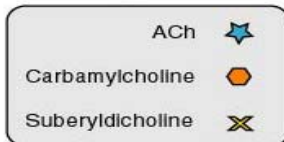

Nicotinic cholinergic transmission provides an excellent example of dose-response behavior at the molecular scale. Different nicotinic agonists bind to the receptor with different affinity, accounting for different levels of occupancy (i.e. the proportion of $L_2 \cdot nAChR$ in scheme 1) at equal agonist concentrations. The rate constants for channel opening and closing, α and β , also depend on the particular ligand, so the time that the ligand-activated channel spends in the conducting state ($L_2 \cdot nAChR^*$) will vary with different ligands. For example, nAChR channels activated by carbachol are only open about half of the time that an acetylcholine-activated channel is open (the lifetime of the open channel is shorter) and, in addition, carbachol is 20-fold less potent (lower affinity) than ACh. On this basis alone, the dose-response curves for channel activation would follow the dashed lines of Figure 4a. On the receptor level, therefore, carbachol is both less efficacious and less potent than ACh.

(The full agonist efficacy projected by the dashed lines in Figure 4a is never reached, however, because the ligands have another action; they block the open channel (see Figure 4b). At high concentrations the dose-response curve "droops" (solid curves, Figure 4a) and the agonists' actions are said to be "biphasic".)

However, at the level of a functioning end-plate or synapse, where hydrolysis of cholinergic ligands is an integral aspect of their action, carbachol appears to be more potent than ACh, because of its relative insensitivity to cholinesterase. A similar result would occur in an intact animal. These examples demonstrate the variation of the dose-response relationship for the same drug among different preparations. **For the purposes of molecular modelling of the receptor, the simplest system is usually desirable, but for a correct clinical evaluation of any drug, the in vivo situation is usually essential.**

Nicotinic cholinergic transmission also occurs at autonomic ganglia (sympathetic and parasympathetic) and in the CNS. There the general mechanisms are very similar to those at the skeletal muscle nmj, but the particular drugs that are effective on neurons differ from those at the

muscle endplate. Table 2 below provides a brief list of different cholinergic synapses and some agonists and antagonists that selectively modify them.

Table 2

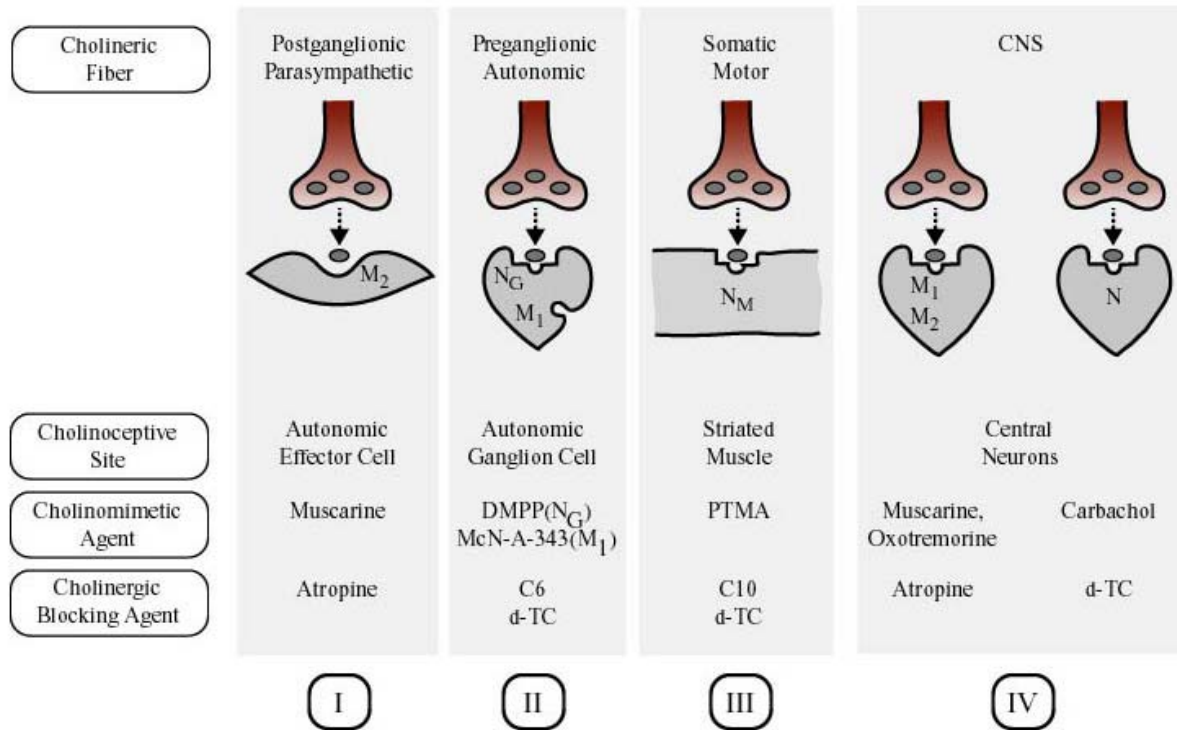

The diversity of drugs that act differentially at different nicotinic cholinergic receptors in the body arises from 2 factors:

1. Multiple forms of the nicotinic receptor exist, all sensitive to ACh but able to discriminate among other ligands.

Recent studies on cloned and endogenous brain nicotinic cholinergic receptors show that

- different subunit compositions produce channels with different conductance and very different open times and
- drugs that are antagonists of peripheral (i.e. muscle) nAChR are agonists or potentiators of certain brain nAChRs. **Therefore the peripheral tissues are improper models for brain nicotinic cholinergic pharmacology.**

2. Access to different organs depends on drug structure. An oft encountered example is a drug which cannot permeate the "blood-brain barrier" and if administered systemically (e.g.

parenterally) only affects peripheral tissues, even though it has the potential to bind to and activate receptors in the CNS.

A picture based on electron microscopic and X-ray analysis of the molecular structure of a nicotinic ACh receptor is shown in Figure 5 below.

5

Each subunit has mass ~ 40 K daltons and the stoichiometry seems always to be $\alpha_2\beta\gamma\delta$ (δ or ϵ). Variations of α and β subunits have been documented (in the genome) and δ and ϵ are, respectively, mature and embryonic forms of homologous subunits expressed in muscle.

B. Muscarinic Cholinergic Transmission. Muscarinic cholinergic transmission occurs in autonomic ganglia, at the end organs innervated by the parasympathetic component of the autonomic nervous system, and in the CNS (Figure 2, Table 2). Several muscarinic receptor types exist, including "M₁", and "M₂" of the peripheral nervous system. **Binding of one ACh to a muscarinic cholinergic receptor (mAChR) produces indirect ligand-gated effects. A variety of second messengers mediate the effects of muscarinic transmission, including reduction of cAMP by inhibition of adenylate cyclase, stimulation of Plipase C (releasing DAG and IP₃) and activation of G-proteins.**

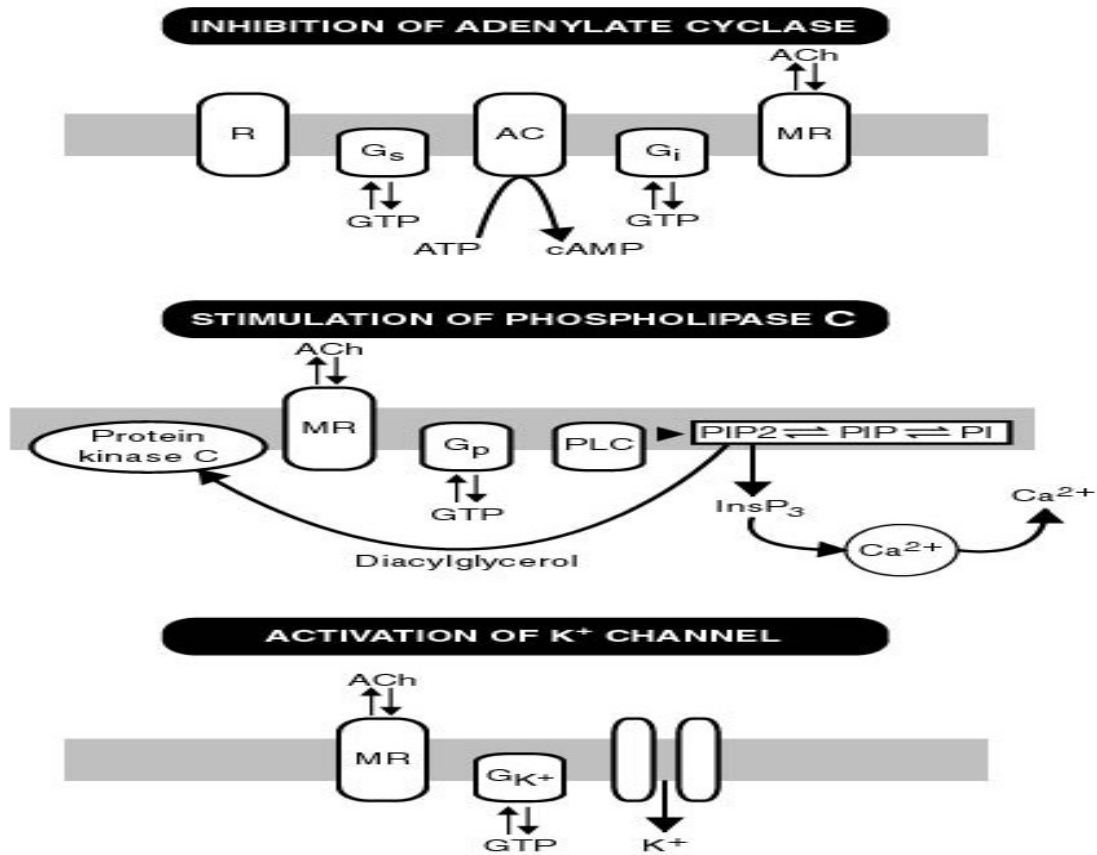

Figure 6

The tissue responses arising from "cascading" series of catalytic events (e.g. kinase activation leading to protein phosphorylation) are relatively slow, whereas those resulting from a direct action of G-proteins (e.g. opening of cardiac K⁺ channel) are much faster. In different tissues, these separate second messengers can elevate or decrease specific ionic conductances, as well as modify other activities, such as the states of contractile proteins. You can appreciate the diversity of responses attending muscarinic transmission by referring to Figure 2 and Table 2. These will be revisited in subsequent lectures.

Muscarinic receptors are sensitive to naturally occurring compounds from plants. (Extracted by treatment with alkaline aqueous solution, these drugs are termed "alkaloids".) The

prototypical agonist alkaloid acting at end organs is muscarine, a product of mushrooms. The classical antagonist is atropine, one of the belladonna alkaloids (see Fig. 2B).

Administration of muscarinic agonists produces a broadly expressed parasympathetic response similar to the activation of the parasympathetic aspects of the autonomic n.s. Such drugs are called "parasympathomimetic". Antagonists of muscarinic transmission have roughly the opposite actions, and are called "parasympatholytic" agents. **However, muscarinic responses may be excitatory or inhibitory depending on the particular tissue, and different autonomic ganglia, effector organs, and CNS receptors differ in their muscarinic responsiveness to various agonists and antagonists,** so the details of the overall in vivo response depend on the particular agent.

The molecular structure of one muscarinic receptor is implied by the primary sequence arrayed in a membrane (Figure 7). The external ligand binding site is coupled through trans-membrane helical segments to the catalytic segment (e.g. G-protein binding region) which resides in the cytoplasmic regions.

Figure 7

See Peralta et al., *Science* 236:600, 1987.

II. Pre-synaptic Receptors in Cholinergic Transmission:

The control of neurotransmitter release is accomplished in several cases by presynaptic autoreceptors (specific for transmitter released) and heteroreceptors (specific for a different transmitter). At the neuromuscular junction, cholinergic agonists can either enhance (acute response, facilitation) or inhibit (chronic response, from repetitive stimulation) the release of ACh. These separate actions occur, respectively, through nicotinic (i.e. curare-sensitive) autoreceptors (enhancement) or muscarinic autoreceptor (inhibition) on the motoneuron terminal. The largest role for such pre-synaptic receptors, however, is in autonomic ganglia and in the CNS. Presynaptic muscarinic receptors inhibit release of ACh from ganglionic cholinergic neurons, the release of glutamate (an excitatory neurotransmitter) from cells in the CNS (hippocampus), and even the release of norepinephrine from the endings of postganglionic sympathetic fibers in the heart and vasculature.

The ionic basis for these inhibitory effects is not established, but both an enhanced K^+ conductance and a reduced Ca^{2+} conductance have been postulated. The first factor will shorten the AP allowing less time for Ca^{2+} entry; the second factor will allow less Ca^{2+} to enter at any one voltage and also will shorten the AP duration. In the case of muscarinic pre-synaptic inhibition, second messengers (e.g. cAMP) most probably mediate the actions but for nicotinic autoreceptors the fast facilitation is likely to be through a direct action on Ca^{2+} channels.

III. The Complexity of Synaptic Transmission: A Ganglionic Example:

Chemical transmission at autonomic ganglia involves multiple transmitters and complex responses (Figure 8). Stimulation of the preganglionic (myelinated B-) fibers leads to a multiphasic response of the postganglionic cell: a fast depolarization, the excitatory postsynaptic potential or EPSP (d_1), is followed by a slower hyperpolarization, the inhibitory postsynaptic potential, or IPSP (h_1), and by an even slower after-depolarization, the slow EPSP (d_2). The use

of selective blocking agents shows that: a) d_1 results from a nicotinic synapse; b) h_1 from one type of muscarinic synapse (K^+ channel activation) and/or from a dopaminergic or adrenergic synapse, with the respective transmitter released by a ganglionic interneuron. The slow EPSP may arise from a second type of muscarinic receptor that inhibits a voltage-dependent K^+ current (the "M-current"). (Membrane depolarization tends to activate M-current channels; the resulting increase in K^+ current prevents further depolarization, and its inhibition by muscarinic agonists permits this depolarization to occur.) In some ganglia there are even slower developing depolarizations (the "late EPSP"), mediated by peptides that bind to their specific postsynaptic receptors; examples of these are the tachykinins, (e.g. Substance P), and the hormone LHRH.

Figure 8

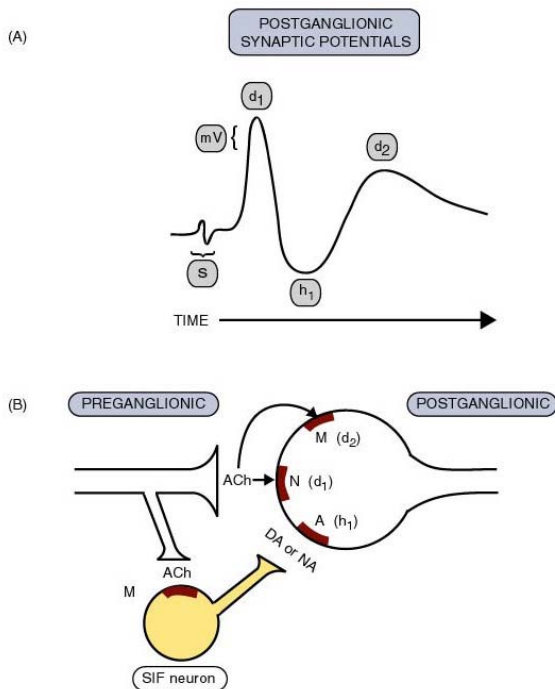

The level of membrane depolarization and the rate of its achievement in postganglionic neurons determines the firing pattern in these cells. Each cell body receives inputs from several preganglionic fibers. Depending on the relative times of arrival and frequencies, these several

inputs induce the release of transmitters at different times. The overall postsynaptic effects are integrated temporally to yield a wave of membrane potential change that passes through the "threshold" for impulse firing. (Impulse activity per se alters the threshold potential, and even under a constant stimulus (synaptic) current the impulse firing frequency will change). **In summary, a "frequency coded" train of impulses in preganglionic axons (the "input") is processed by the graded changes of membrane potential in the ganglia and emerges as a frequency coded burst of impulses conducted along the postganglionic (non-myelinated C-) fibers (the "output"). Similar events occur throughout the nervous system. Unlike the nmj, where the end plate potential is always sufficient to excite the perijunctional excitable muscle membrane, at neuronal synapses the individual postsynaptic potentials (psp's) are much smaller than that required for postsynaptic excitation and some form of integration is required to reach threshold.** Where synapses are located on neuronal dendrites, far away from the impulse "initiation zone" (e.g. in skeletal motoneurons), the spatial as well as the temporal aspect of integration is important.

III. Cholinergic Pharmacology

Like acetylcholine, many of the cholinergic agonists and antagonists contain quaternary ammonium moieties (NR_4^+) and are permanently cationic. Sometimes they are tertiary amine bases with high pK_a s so that they are largely protonated and positively charged at physiological pH.

Since the AChesterase (AChase) enzyme also is selective for Ach, many reversible antagonists of this esterase also are quaternary amines. Other, irreversible inhibitors of AChase are organophosphate molecules (often used as pesticides) that form covalent bonds with the enzyme's active site.

One class of very slowly reversible (days to unbind) antagonists of nAChR are small proteins (6-8000 mol wt) in venoms of certain snakes (Formosan Krait, cobra). These molecules called *bungarotoxins* bind to the α subunits of the receptor from the extracellular surface and

were essentially for the original isolation and purification of the receptor. Natural peptide toxins are often useful research tools in pharmacology, because of their high affinity and specificity, and occasionally are used therapeutically.

Drugs acting at cholinergic synapses are used both therapeutically and for intended toxicologies. A brief list includes:

1. Neuromuscular blocking agents, both non-depolarizing and depolarizing, are used intraoperatively as muscle relaxants.

2. Ganglionic blocking agents, rarely given therapeutically, may be used for the production of controlled hypotension (usually intraoperative). Certain traumas may prevent the normal delivery of inhibitory impulses from the CNS to the autonomic ganglia, resulting in autonomic hyperreflexia; whose symptoms can be controlled with ganglionic blockers.

3. Anti-muscarinic agents (e.g. scopolamine) are used to reduce secretions during general anesthesia, to antagonize the poisoning from anti-acetylcholinesterases (e.g. organophosphates, such as occur in insecticides) for the prevention of motion sickness, and occasionally, for sedation and amnesia. (The previous use of antimuscarinics to reduce vagal innervation of the GI tract, and thus lessen gastric secretions and ulcers, has been superseded by the H₂-receptor blocking agents.)

4. Cholinesterase inhibitors are used to ameliorate or reverse the effects of anti-cholinergic agents. In the case of inadvertent toxicity (e.g. mushroom poisoning), the therapeutic actions are designed to occur primarily at ganglionic and muscarinic junctions of end organs. (Why?) For the reversal of non-depolarizing blockers of neuromuscular transmission, the esterase inhibitors (e.g. neostigmine, physostigmine) are designed to act at the peripheral muscle end-plates.

None of the types of drugs listed above has high specificity for one site of action and, as with almost all therapeutics, none is without side effects.

Recommended Readings

General and reviews

1. Goodman and Gilman's The Pharmacological Basis of Therapeutics. (10th ed.) Chapters 6, 7, 8, and 9, and parts of Chapter 12 concerning ACh.
2. The Biochemical Basis of Neuropharmacology (eds. Cooper JR, Bloom FE, Roth RH.; 6th ed.) Chapters 2, 4, 5, 6, 8.
3. Basic Neurochemistry (eds. Siegel G. et al.; 4th ed.).
Chapters 8-10
4. Mechanisms of Drug Action on the Nervous System. Ryall RW. Cambridge Univ. Press, 1989. Chapters 3-5.
5. Changeux JP et al. Chemical Signalling in the Brain. *Scientific American* 269(Nov):58, 1993.
6. Colquhoun D et al. Nicotinic acetylcholine receptors of nerve and muscle: functional aspects. *Scientific American* 269(Nov) 465-471, 1993.
7. Bowman, WC. Review: Prejunctional and postjunctional cholinceptors at the neuromuscular junction. *Anes. and Analg.* 59: 935-943, 1980.
8. Bowman WC, Marshall IG, Gibb AJ and Harbone AJ. Review: Feedback control of transmitter release at the neuromuscular junction. *Trends in Pharmacological Sciences*, 9:16-20.

B. Selected articles

Shen W-X, and Horn JP. A presynaptic mechanism accounts for the differential block of nicotinic synapses on sympathetic B and C neurons by *d*-tubocurarine. *J. Neurosci.* 15(7):5025-5035, 1995.

Sivilotti L and Colquhoun D. Acetylcholine Receptors: Too many channels, too few functions. *Science.* 269:1681-1682, 1995.

McGehee DS, Heath MJS, Gelber S, Devay P, Role LW. Nicotine enhancement of fast excitatory synaptic transmission in CNS by presynaptic receptors. *Science.* 269:1692-1696, 1995.

Caufield MP: Muscarinic receptors-characterization, coupling and function. *Pharmacol. Ther.* 58:319-379, 1993.

Wess J: Molecular basis of muscarinic acetylcholine receptor function. *Trends Pharmacol. Sci.* 14:308-313, 1993.

Marchi M, Bocchieri P, Garbarino L, Raiteri M. Muscarinic inhibition of endogenous glutamate release from rat hippocampus synaptosomes. *Neurosci. Lett.* 96:229-234, 1989.

Calabresi P, Lacey MG, and North RA. Nicotinic excitation of rat ventral tegmental neurones in vitro studied by intracellular recording. *Br. J. Pharmacol.* 98:135-140, 1989.

Wong LA and Gallagher JP. A direct nicotinic receptor-mediated inhibition recorded intracellularly in vitro. *Nature* 341:439-442, 1989.

Pfeiffer-Linn C and Glantz RM. Acetylcholine and GABA Mediate Opposing Actions on Neuronal Chloride Channels in Crayfish. *Science* 245:1249-1251, 1989.

Sorota S and Hoffman BF. Role of G proteins in the acetylcholine-induced potassium current of canine atrial cells. *Am. J. Physiol.* 257 (Heart Circ. Physiol 26): H1516-H1522, 1989.

Logothetis DE, Kurachi Y, Galper J, Neer EJ, and Clapham DE. The $\beta\gamma$ subunits of GTP-binding proteins activate the muscarinic K^+ channel in heart. *Nature* 325:321-326, 1987.

Grenningloh G, Rienitz A, Schmitt B., Methfessel C, Zensen M, Beyreuther K, Gundelfinger ED, Betz H. The strychnine-binding subunit of the glycine receptor shows homology with nicotinic acetylcholine receptors. *Nature* 328:215-227, 1987.

Leonard RJ, Labarca CG, Charnet P, Davidson N, Lester HA. Evidence that the M2 membrane-spanning region lines the ion channel pore of the nicotinic receptor. *Science* 242:1578-1581, 1988.

Ali H.H, Utting J.E., and Gray C. Stimulus frequency in the detection of neuromuscular block in humans. *Br. J. of Anaes.* 42:967-977, 1970/